

Schematic:

REV.	ECN NO.	DESCRIPTION	DATE	APPD
A	REL		13/10/2009	

PCB SIDE

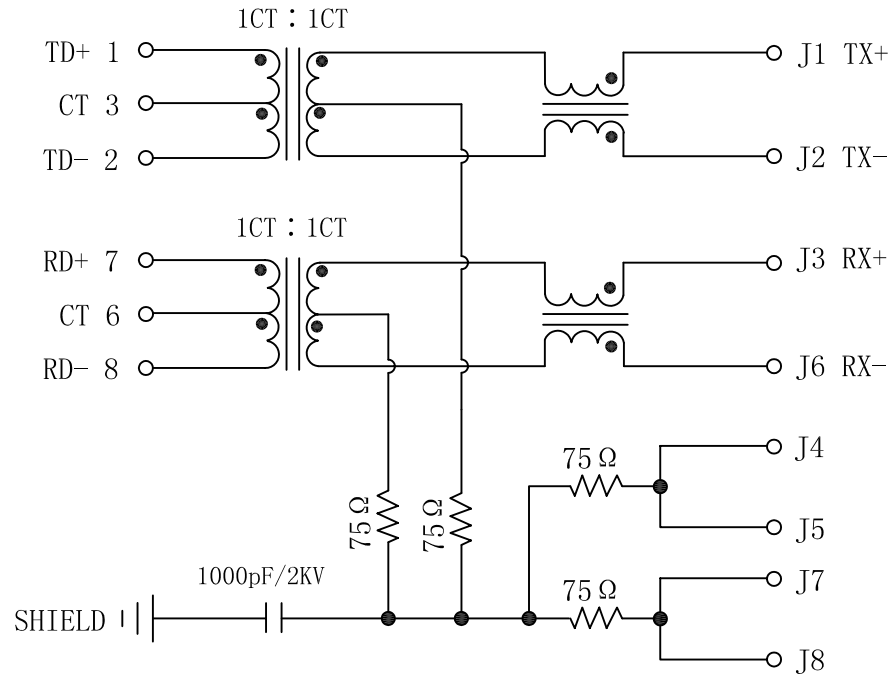

CABLE SIDE

ELECTRICAL SPECIFICATIONS @25°C

- Turn Ratio($\pm 2\%$):
TX=1CT : 1CT RX=1CT : 1CT
- Inductance OCL: 350uH MIN
@100KHz/0.1V 8mA DC Bias
- Insertion Loss:
-1.0dB MAX @ 0.3-100MHz
- Return Loss(@100Ω):
-18dB MIN @ 1-30MHz
-16dB MIN @ 40MHz
-14dB MIN @ 50MHz
-12dB MIN @ 60-80MHz
- Cross talk:
-45dB MIN @ 30MHz
-40dB MIN @ 60MHz
-35dB MIN @ 100MHz
- Common Mode Rejection:
-35dB MIN @ 30MHz
-30dB MIN @ 60MHz
-25dB MIN @ 100MHz
- Hipot Test: 1500Vrms MIN
- Operating Temperature Range: -40°C TO +85°C

GREEN/LEFT LED

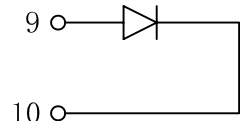

YELLOW/RIGHT LED

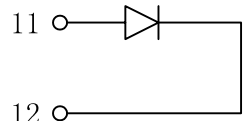

X:X ±0.25	APPD:	LINK-PP INT'L TECHNOLOGY CO., LIMITED		
X:XX ±0.20	CHKD:	TITLE: RJ45 Connector with 10/100 Base-T Integrated Magnetics		
X:XXX ±0.05	DR: TOM	PART NO.: LPJ4017GENL		
ANGLES ±1°	UNIT: mm			
	SCALE: 2/1	SHEET: 1/2	REV: A	DWG NO.: LP09101306

Mechanical:

REV.	ECN NO.	DESCRIPTION	DATE	APPD
A	REL		13/10/2009	

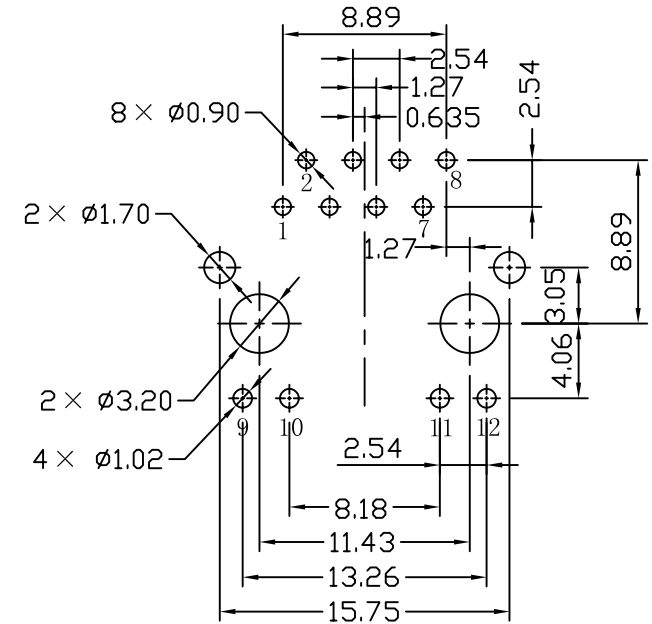
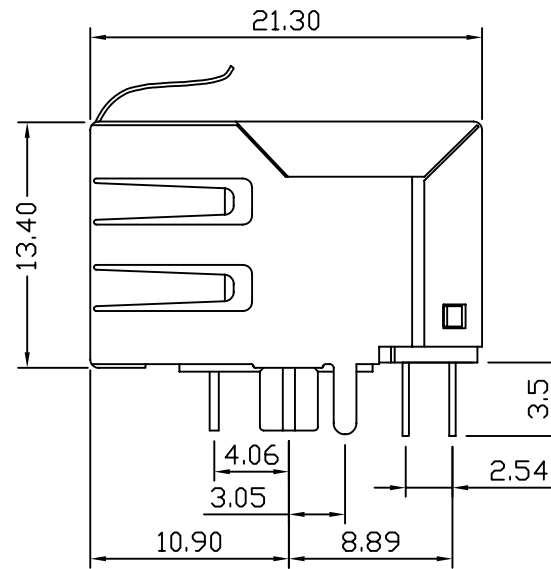
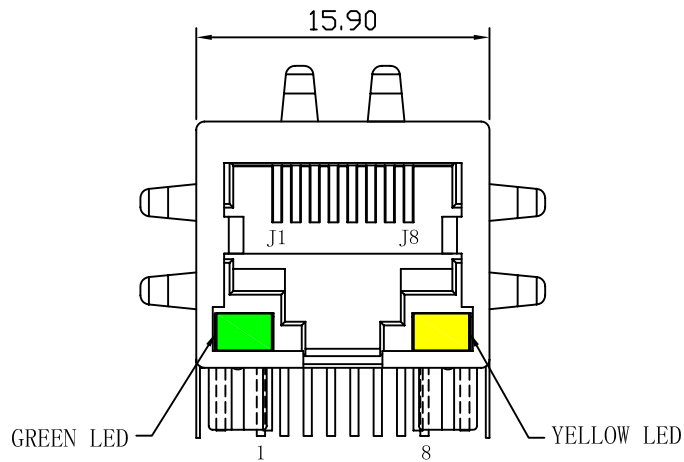

SUGGESTED PCB LAYOUT (TOP VIEW)

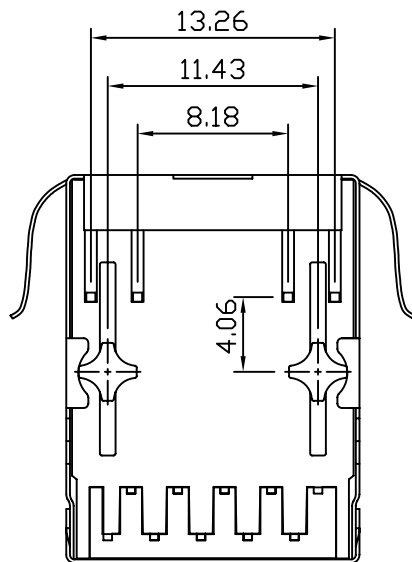

NOTES:

1. Designed to support application, such as SOHO (ADSL modems), LAN-on-Motherboard (LOM), hub and Switches.
2. Meets IEEE 802.3 specification
3. Connector Materials:
 Housing: Thermoplastic UL94V-0
 Contact/Shield: Copper alloy
 Shield plating: Nickel
 Contact plating: Gold 6 micro-inches min. In contact area.
4. Wave solder tip temperature: 265°C Max
 Wave solder tip temperature time: 5 Sec Max.

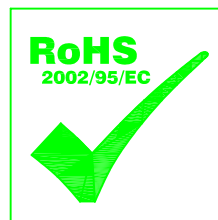

X:X ±0.25	APPD:	LINK-PP INT'L TECHNOLOGY CO., LIMITED
X:XX ±0.20	CHKD:	
X:XXX ±0.05	DR: TOM	TITLE: RJ45 Connector with 10/100 Base-T Integrated Magnetics
ANGLES ±1°	UNIT: mm	PART NO.: LPJ4017GENL
	SCALE: 2/1	SHEET: 2/2
	REV: A	DWG NO.: LP09101306