

Schematic:

REV.	ECN NO.	DESCRIPTION	DATE	APPD
A	REL		2010/12/04	

LAN CHIP SIDE

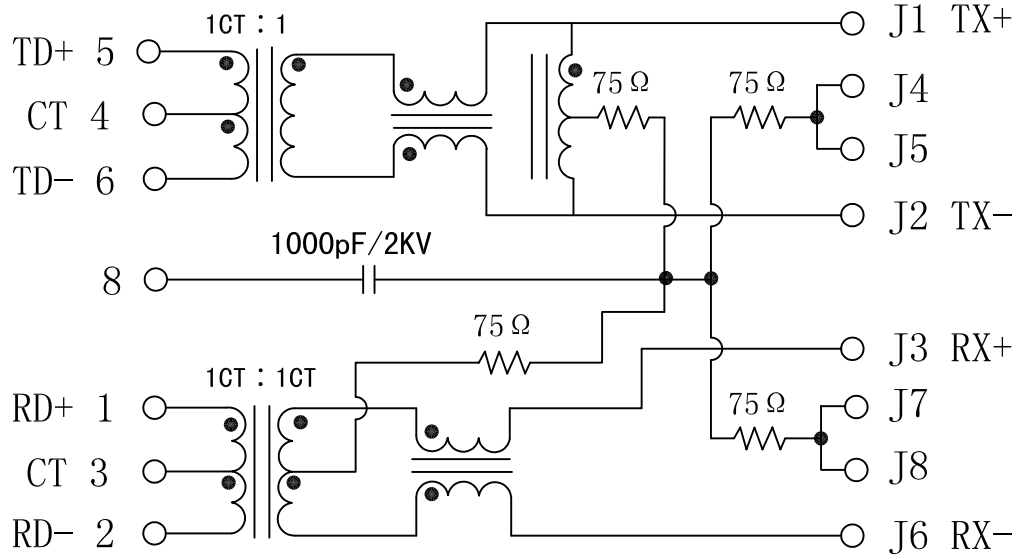

RJ CABLE SIDE

Electrical Specifications: @25°C

- Turns Ratio ($\pm 2\%$):
TX=1CT:1 RX=1CT:1CT
- Primary Inductance(1-2, 5-6):
350uH min @100KHz, 0.1Vrms, 8mA DC bias
- Insertion Loss:
1-100MHz: -1.0dB Max
- Return Loss(dB Min):
1-30MHz:-20; 30-60MHz:-16
60-80MHz:-12
- Crosstalk: 1-100MHz: -30dB Min
- Common Mode Rejection:
1-100MHz: -30dB Min
- Hipot Test: 1500Vrms
- Operating Temperature: 0~70°C.

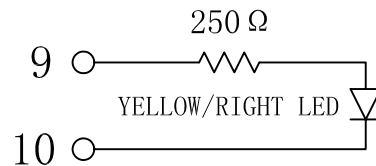
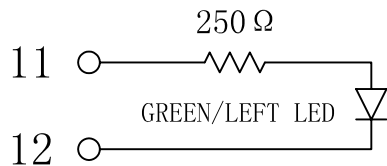

X:X	± 0.20	APPD:	LINK-PP INT'L TECHNOLOGY CO., LIMITED	
X:XX	± 0.10	CHKD:	Title: RJ45 Connector With 10/100 Base-TX Integrated Magnetic TAB-UP	
X:XXX	± 0.05	DR: TOM		
ANGLES	$\pm 1^\circ$	UNIT: mm	PART NO.: LPJ16206A28NL	
	SCALE: 2/1	SHEET: 1/2	REV: A	DWG NO: LP10120403

Mechanical:

REV.	ECN NO.	DESCRIPTION	DATE	APPD
A	REL		2010/12/04	

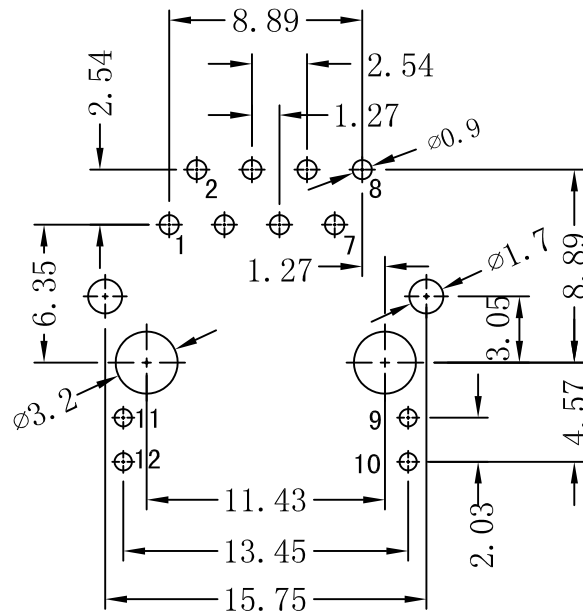
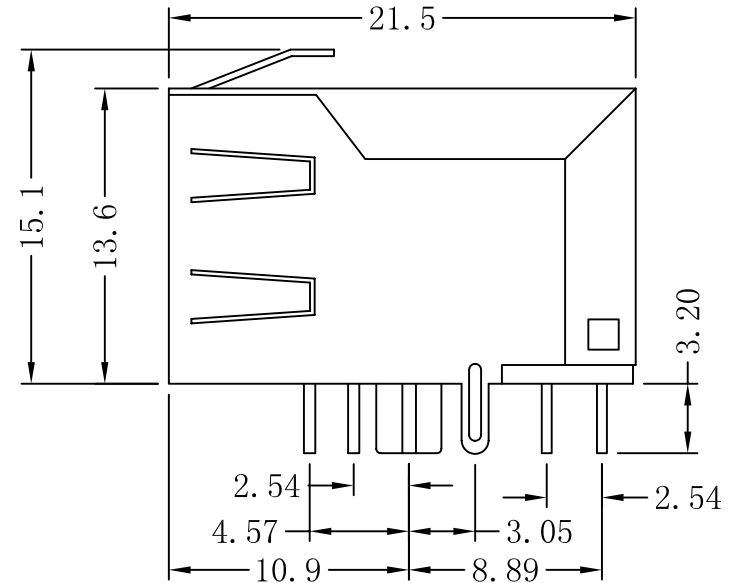
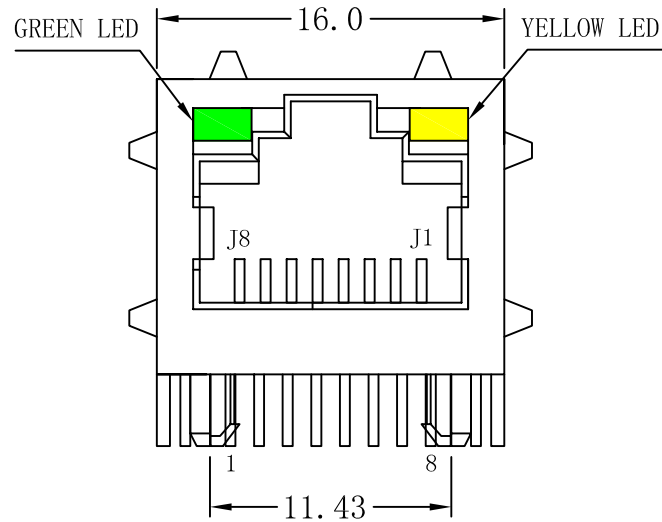

SUGGESTED PCB LAYOUT (TOP VIEW)



NOTES:

1. Designed to support application, such as SOHO (ADSL modems), LAN-on-Motherboard (LOM), hub and Switches.
2. Meets IEEE 802.3 specification
3. Connector Materials:
Housing: Thermoplastic UL94V-0
Contact/Shield: Copper alloy
Shield plating: Nickel
Contact plating: Gold 6 micro-inches min. In contact area.
4. Wave solder tip temperature: 265°C MAX
Wave solder tip temperature time: 5 Sec MAX.

X:X	±0.20	APPD:	LINK-PP INT'L TECHNOLOGY CO., LIMITED
X:XX	±0.10	CHKD:	Title: RJ45 Connector With 10/100 Base-TX Integrated Magnetic TAB-UP
X:XXX	±0.05	DR: TOM	PART NO.: LPJ16206A28NL
ANGLES	±1°	UNIT: mm	
	SCALE: 2/1	SHEET: 2/2	REV: A DWG NO: LP10120403