

Schematic:

REV.	ECN NO.	DESCRIPTION	DATE	APPD
A	REL		2010/03/20	

PCB SIDE TO PHY

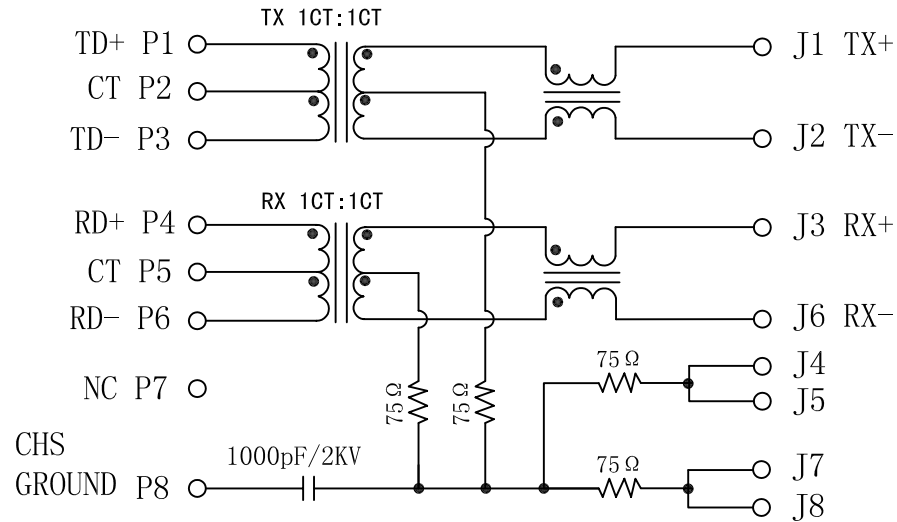

CABLE SIDE

ELECTRICAL SPECIFICATIONS @25°C

- Turn Ratio($\pm 2\%$):
TX=1CT:1CT RX=1CT:1CT
- Inductance OCL: 350uH MIN
@ 100KHz/0.1V 8mA DC Bias
- Insertion Loss:
1. 0-100MHz:-1.0dB MAX
- Return Loss(dB MIN):
1-30MHz: -18 30-60MHz:-15
60-80MHz: -12 80-100MHz:-10
- Cross talk(dB MIN):
30MHz: -40 60MHz: -35
100MHz:-30
- Common Mode Rejection(dB MIN):
30MHz: -40 60MHz: -35
100MHz:-30
- Hipot Test:1500Vrms
- Operating Temperature Range: 0°C TO 70°C

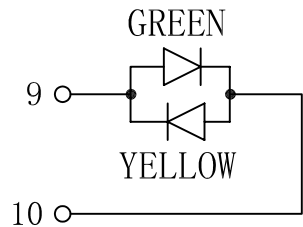

LEFT LED

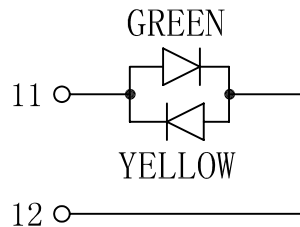

RIGHT LED

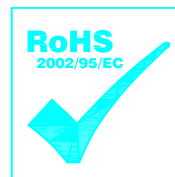

X:X ±0.25	APPD:	LINK-PP INT'L TECHNOLOGY CO., LIMITED		
X:XX ±0.20	CHKD:	TITLE: RJ45 Connector with 10/100 Base-T Integrated Magnetics		
X:XXX ±0.05	DR: TOM	PART NO. : LPJ0012G4NL		
ANGLES ±1°	UNIT: mm			
	SCALE: 2/1	SHEET: 1/2	REV: A	DWG NO. : LP10032003

Mechanical:

REV.	ECN NO.	DESCRIPTION	DATE	APPD
A	REL		2010/03/20	

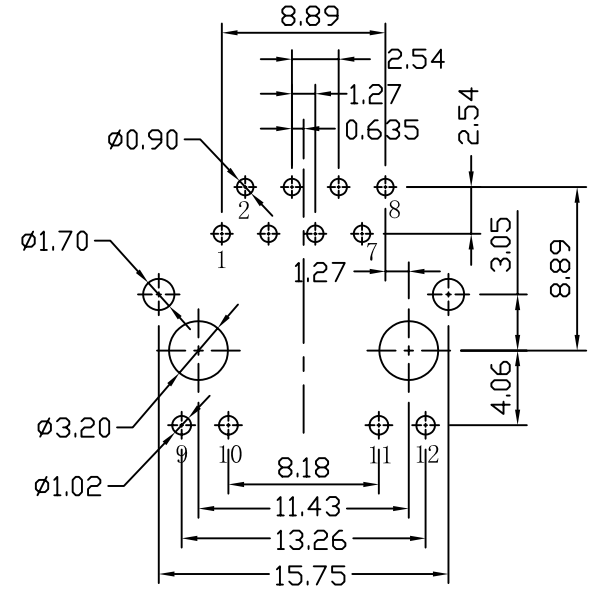
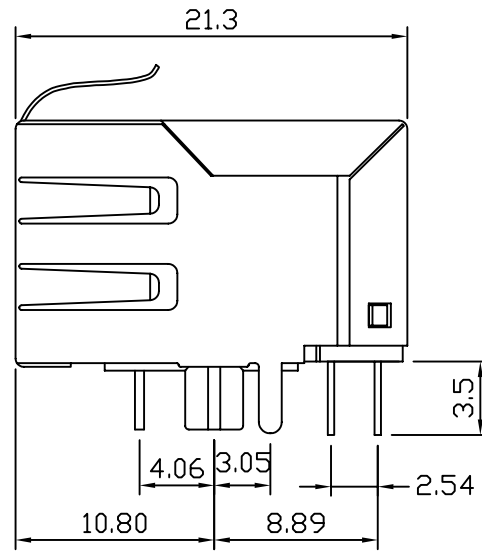
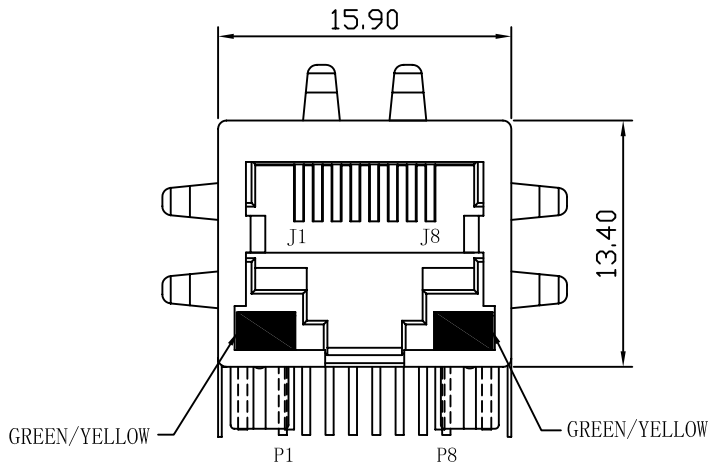

SUGGESTED PCB LAYOUT (TOP VIEW)

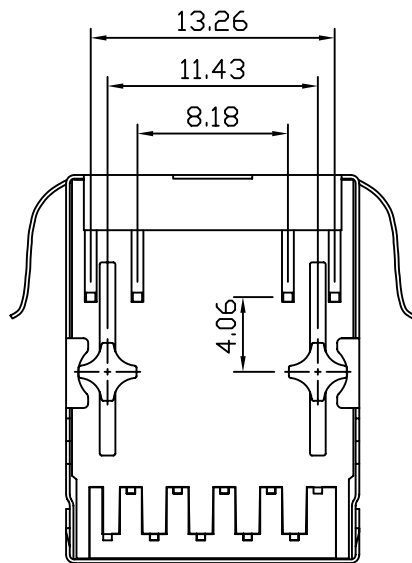

NOTES:

1. Designed to support application, such as SOHO (ADSL modems), LAN-on-Motherboard (LOM), hub and Switches.
2. Meets IEEE 802.3 specification
3. Connector Materials:
 Housing: Thermoplastic UL94V-0
 Contact/Shield: Copper alloy
 Shield plating: Nickel
 Contact plating: Gold 6 micro-inches min. In contact area.
4. Wave solder tip temperature: 265°C Max
 Wave solder tip temperature time: 5 Sec Max.



X:X	±0.25	APPD:	LINK-PP INT'L TECHNOLOGY CO., LIMITED	
X:XX	±0.20	CHKD:	TITLE: RJ45 Connector with 10/100 Base-T Integrated Magnetics	
X:XXX	±0.05	DR: TOM		
ANGLES	±1°	UNIT: mm	PART NO. : LPJ0012G4NL	
	SCALE: 2/1	SHEET: 2/2	REV: A	DWG NO. : LP10032003