

FEATURES

- Operates from $\pm 5V$ to $\pm 15V$ Supplies
- Fully Protected Against Overload
- Outputs can be Driven $\pm 30V$ without Damage
- Three-State Outputs; Outputs Open when Off
- Bipolar Circuit—No Latch Up
- $\pm 30V$ Input Range
- Triple Driver/Receiver
- No Supply Current in Shutdown
- $30k\Omega$ Input Impedance
- Meets All RS232 Specifications
- 16 Pin Version—Pin Compatible with MC145406
- Available in SO Package

APPLICATIONS

- RS232 Interface
- Terminals
- Modems

DESCRIPTION

The LT1039 is a triple RS232 driver/receiver which includes SHUTDOWN. Each receiver will accept up to $\pm 30V$ input and can drive either TTL or CMOS logic. The RS232 drivers accept TTL logic inputs and output RS232 voltage levels. The outputs are fully protected against overload and can be shorted to ground or up to $\pm 30V$ without damage to the drivers. Additionally, when the system is shut down or power is off, the outputs are in a high impedance state allowing data line sharing. Bipolar circuitry makes this driver/receiver exceptionally rugged against overloads or ESD damage.

A bias pin allows one receiver to be kept on while the rest of the part is shut down.

The 1039 is also available in the 16 pin version, without shutdown or bias pin functions.

For applications requiring operation from a single 5V supply, see LT1080/81 datasheet.

TYPICAL APPLICATION

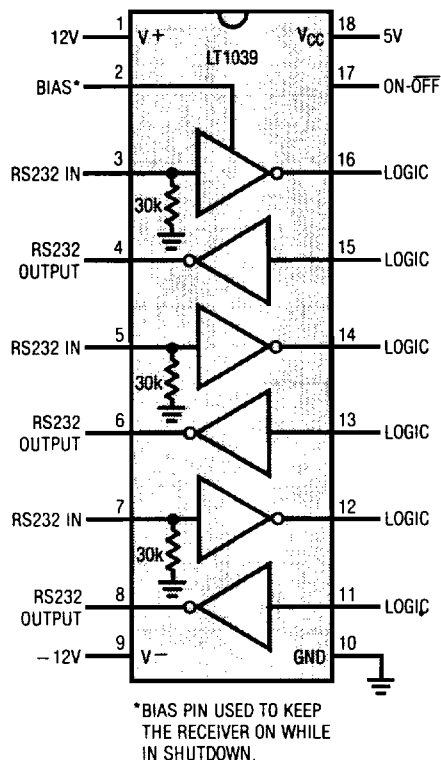

Driver Output Swing

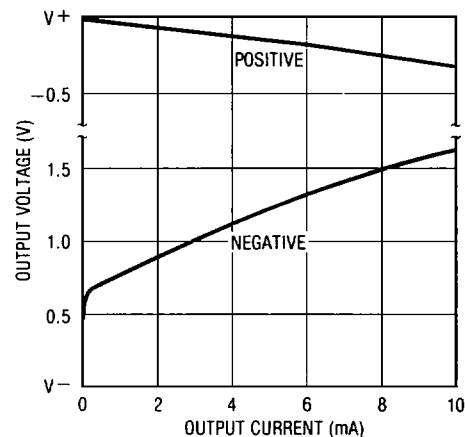

ABSOLUTE MAXIMUM RATINGS

Supply Voltage
 Driver ($V+$, $V-$) $\pm 16V$
 Receiver (V_{CC}) $7V$
 Logic Inputs $V-$ to $25V$
 Receiver Inputs $\pm 30V$
 On-Off Input GND to $12V$
 Driver Outputs $V- + 30V$ to $V+ - 30V$
 Short Circuit Duration Indefinite
 Operating Temperature Range
 LT1039M $-55^{\circ}C$ to $125^{\circ}C$
 LT1039C $0^{\circ}C$ to $70^{\circ}C$
 Guaranteed Functional by Design $-25^{\circ}C$ to $85^{\circ}C$
 Lead Temperature (Soldering, 10 sec.) $300^{\circ}C$

PACKAGE/ORDER INFORMATION

<p>TOP VIEW V+ 1, REC1 IN 2, TR1 OUT 3, REC2 IN 4, TR2 OUT 5, REC3 IN 6, TR3 OUT 7, V- 8, 16 VCC, 15 REC1 OUT, 14 TR1 IN, 13 REC2 OUT, 12 TR2 IN, 11 REC3 OUT, 10 TR3 IN, 9 GND</p> <p>J PACKAGE 16-LEAD CERAMIC DIP N PACKAGE 16-LEAD PLASTIC DIP</p>	ORDER PART NUMBER LT1039CN16 LT1039CJ16 LT1039MJ16
<p>TOP VIEW V+ 1, BIAS 2, REC1 IN 3, TR1 OUT 4, REC2 IN 5, TR2 OUT 6, REC3 IN 7, TR3 OUT 8, V- 9, 18 VCC, 17 ON-OFF, 16 REC1 OUT, 15 TR1 IN, 14 REC2 OUT, 13 TR2 IN, 12 REC3 OUT, 11 TR3 IN, 10 GND</p> <p>J PACKAGE 18-LEAD CERAMIC DIP S PACKAGE 18-LEAD PLASTIC SOL N PACKAGE 18-LEAD PLASTIC DIP</p>	LT1039CN LT1039CJ LT1039MJ LT1039CS

ELECTRICAL CHARACTERISTICS

PARAMETER	CONDITIONS	MIN	TYP	MAX	UNITS
Driver $V+ = 12V$; $V- = -12V$; $V_{ON-OFF} = 2.5V$					
Output Voltage Swing	Load = 3k to Ground	Positive Negative	$V+ - 0.4$ $V- + 1.5$	$V+ - 0.1$ $V- + 1$	V V
Logic Input Voltage Levels	Input Low Level ($V_{OUT} = High$) Input High Level ($V_{OUT} = Low$)	● ●	2.0	1.4 1.4	0.8 V V
Logic Input Current	$V_{IN} \geq 2.0V$ $V_{IN} \leq 0.8V$			1 5	20 20 μA μA
Output Short Circuit Current	Sourcing Current, $V_{OUT} = 0V$ Sinking Current, $V_{OUT} = 0V$		5 -5	15 -15	mA mA
Output Leakage Current	SHUTDOWN (Notes 1 and 2); $V_{OUT} = \pm 18V$, $V_{IN} = 0$	●		10 (25°C)	200 μA
Supply Leakage Current	SHUTDOWN (Note 1)	●		1 (25°C)	100 μA
Slew Rate	$R_L = 3k\Omega$; $C_L = 51pF$		4	15	30 V/ μs
Supply Current	$V_{OUT} = Low$			4	8 mA
Receiver $V_{CC} = 5V$; $V_{ON-OFF} = 2.5V$					
Input Voltage Thresholds	Input Low ($V_{OUT} = High$) Input High ($V_{OUT} = Low$)	● ●	0.5	1.3 1.7	2.8 V V
Hysteresis		●	0.1	0.4	1.0 V
Input Resistance		●		30	k Ω
Output Voltage	Output Low, $I_{OUT} = -1.6mA$ Output High, $I_{OUT} = 160\mu A$	● ●	3.5	0.4 4.8	0.5 V V
Output Short Circuit Current	Sinking Current, $V_{OUT} = V_{CC}$ Sourcing Current, $V_{OUT} = 0V$ (Note 3)	● ●	-10 0.5	1	mA mA
Output Leakage Current	SHUTDOWN (Note 1); $0V \leq V_{OUT} \leq V_{CC}$, $V_{IN} = 0$	●		1	10 μA
Supply Current		●		4	7 mA

ELECTRICAL CHARACTERISTICS

PARAMETER	CONDITIONS		MIN	TYP	MAX	UNITS
Supply Leakage Current	SHUTDOWN (Note 1)	●		1 (25°C)	100	μA
On-Off Pin Current	$0V \leq V_{ON-OFF} \leq 5V$	●	-15		80	μA

The ● denotes specifications which apply over the operating temperature range.

Note 1: $V_{ON-OFF} = 0.4V$ for $-55^{\circ}C \leq T_A \leq 100^{\circ}C$, and $V_{ON-OFF} = 0.2V$ for $100^{\circ}C \leq T_A \leq 125^{\circ}C$. Does not apply to LT1039-16 part.

Note 2: For $T_A \geq 100^{\circ}C$, leakage current is $350\mu A$ max.

Note 3: For $T_A \leq -25^{\circ}C$, output source current is 0.4 mA.

PIN FUNCTIONS (Pin numbers listed are for 18 pin device).

V⁺, V⁻ (Pins 1, 9): Driver supply pins. Supply current drops to zero in SHUTDOWN mode. Driver outputs are in a high impedance state when V^+ and $V^- = 0V$.

V_{CC} (Pin 18): 5V power for receivers.

GND (Pin 10): Ground pin.

TR IN (Pins 11, 13, 15): RS232 driver input pins. Inputs are TTL/CMOS compatible. Inputs should not be allowed to float. Tie unused inputs to V_{CC}.

TR OUT (Pins 4, 6, 8): Driver outputs with RS232 voltage levels. Outputs are in a high impedance state when in the SHUTDOWN mode or when power is off (V^+ and $V^- = 0V$) to allow data line sharing. Outputs are fully short circuit protected from $V^- + 30V$ to $V^+ - 30V$ with power on, off, or in the SHUTDOWN mode. Typical output breakdowns are greater than $\pm 45V$ and higher applied voltages will not damage the device if moderately current limited.

REC IN (Pins 3, 5, 7): Receiver input pins. Accepts RS232 voltage levels ($\pm 30V$) and has 0.4V of hysteresis to provide noise immunity. Input impedance is nominally 30kΩ.

REC OUT (Pins 12, 14, 16): Receiver outputs with TTL/CMOS voltage levels. Outputs are in a high impedance state when in the SHUTDOWN mode to allow data line sharing. Outputs are fully short circuit protected to ground or V_{CC} with power on, off, or in the SHUTDOWN mode.

ON-OFF (Pin 17): Controls the operation mode of the LT1039 and is TTL/CMOS compatible. A logic low puts the device in the SHUTDOWN mode which reduces input supply current to zero and places both driver and receiver outputs in a high impedance state.

BIAS (Pin 2): Keeps receiver 1 on while the LT1039 is in the SHUTDOWN mode. Leave BIAS pin open when not in use. See Application Hints for proper use.

TYPICAL PERFORMANCE CHARACTERISTICS

Driver Output Short Circuit Current

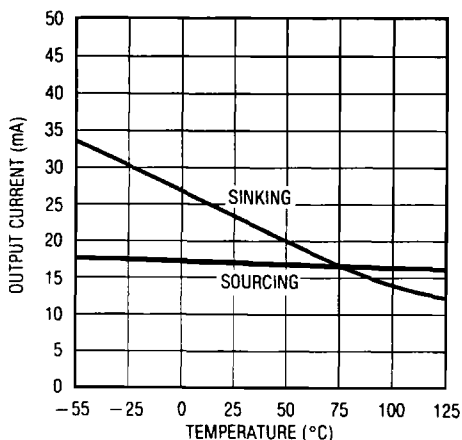

Receiver Input Thresholds

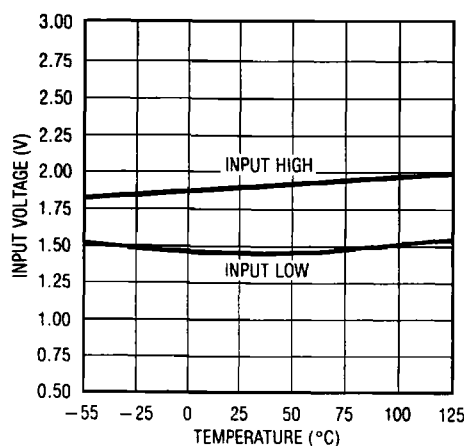

On-Off Pin Thresholds

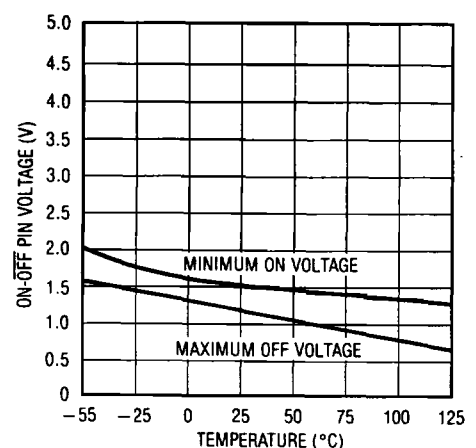

TYPICAL PERFORMANCE CHARACTERISTICS

Supply Current in SHUTDOWN

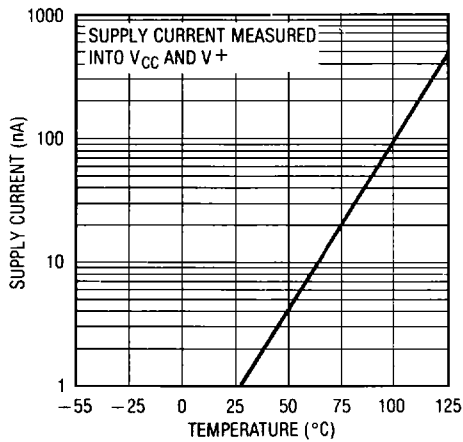

Driver Output Leakage in SHUTDOWN

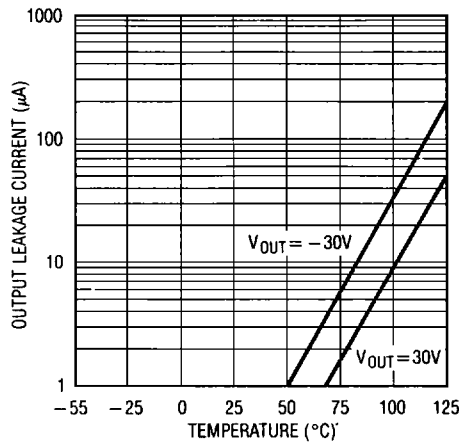

Receiver Output Short Circuit Current

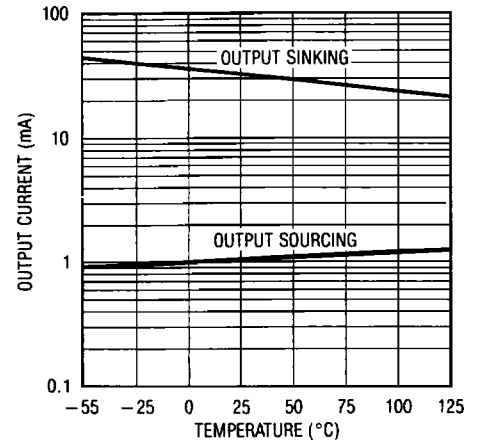

On-Off Pin Current vs Voltage

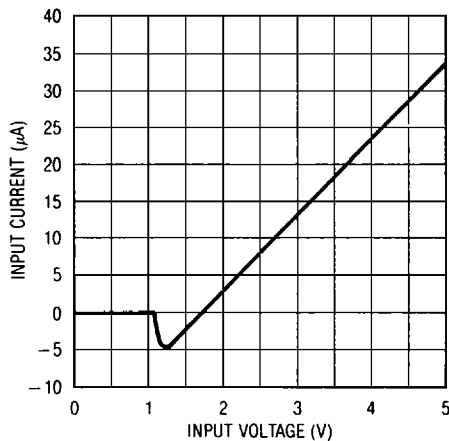

Driver Output Swing vs Current

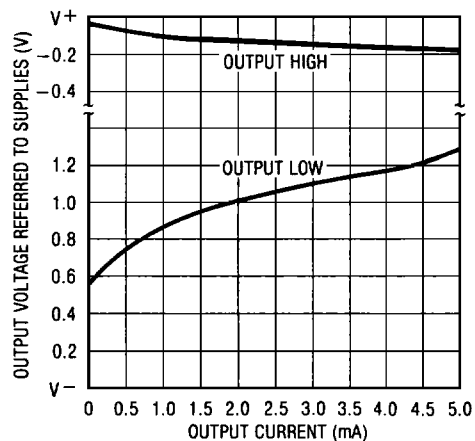

Output Waveforms

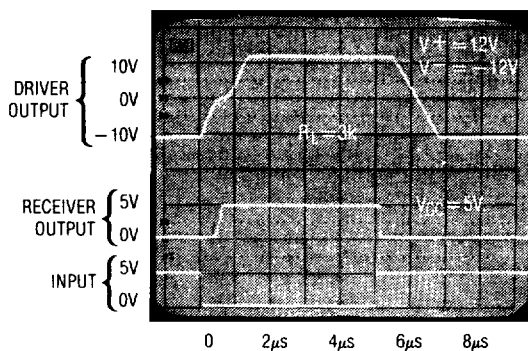

SHUTDOWN to Driver Output

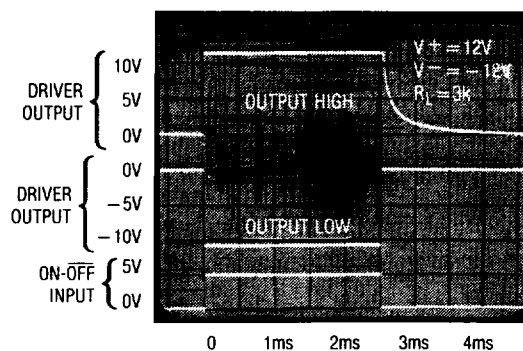

TYPICAL PERFORMANCE CHARACTERISTICS

SHUTDOWN to Receiver Output

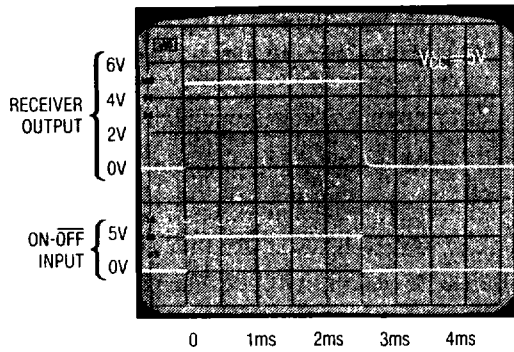

Bias Pin Response Time

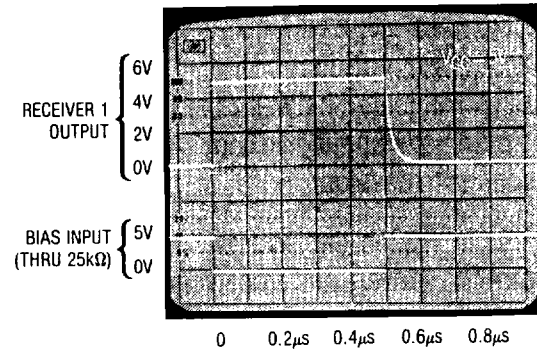

TYPICAL APPLICATION

LT1080 (Driver/Receiver with Power Supply) Driving an LT1039

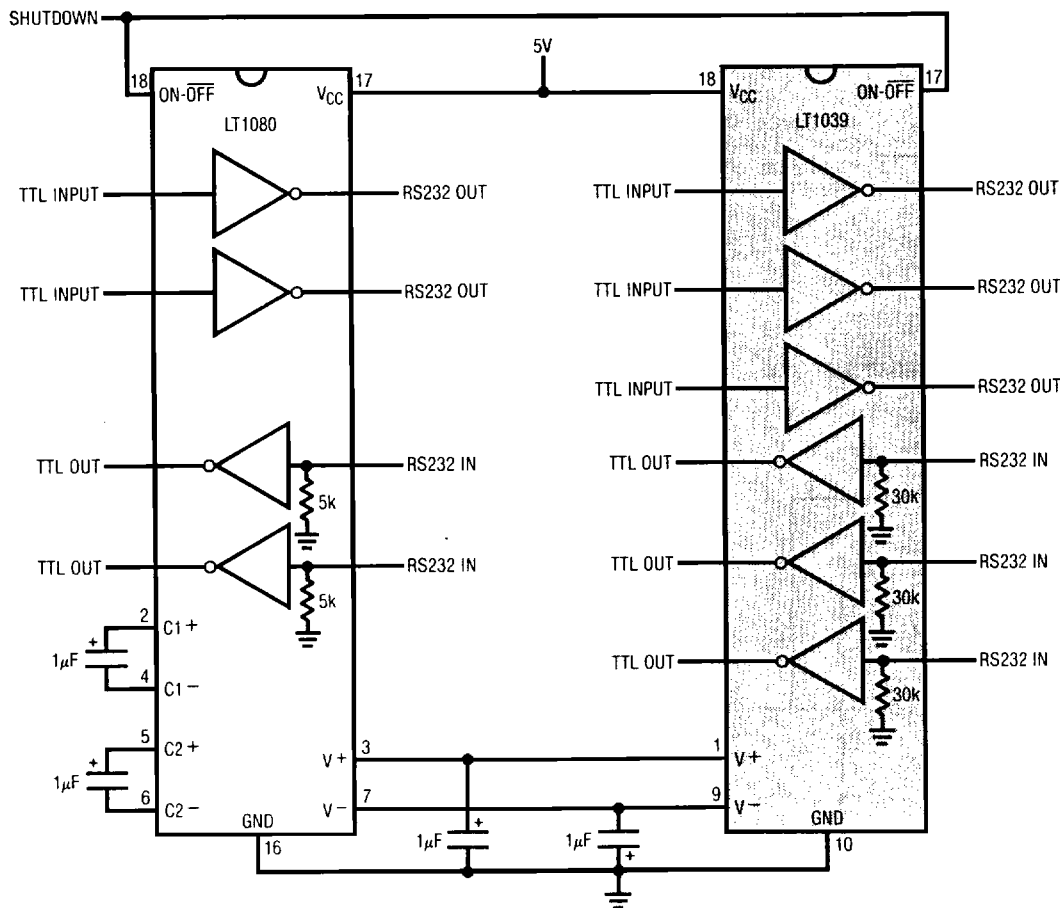

APPLICATION HINTS

The driver output stage of the LT1039 offers significantly improved protection over older bipolar and CMOS designs. In addition to current limiting, the driver output can be externally forced to $\pm 30V$ with no damage or excessive current flow, and will not disrupt the supplies. Some drivers have diodes connected between the outputs and the supplies, so externally applied voltages can cause excessive supply voltage to develop.

Placing the LT1039 in the SHUTDOWN mode (Pin 17 low) puts both the driver and receiver outputs in a high

impedance state. This allows data line sharing and transceiver applications.

The SHUTDOWN mode also drops all supply currents (V_{CC} , V^+ , V^-) to zero for power-conscious systems.

When driving CMOS logic from a receiver that will be used in the SHUTDOWN mode and there is no other active receiver on the line, a 51k resistor can be placed from the logic input to V_{CC} to force a definite logic level when the receiver output is in a high impedance state.

LT1039 Driver

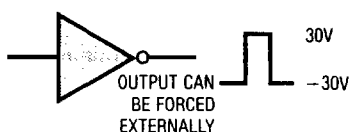

Older RS232 Drivers and Other CMOS Drivers

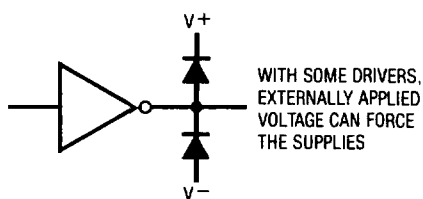

Sharing a Receiver Line

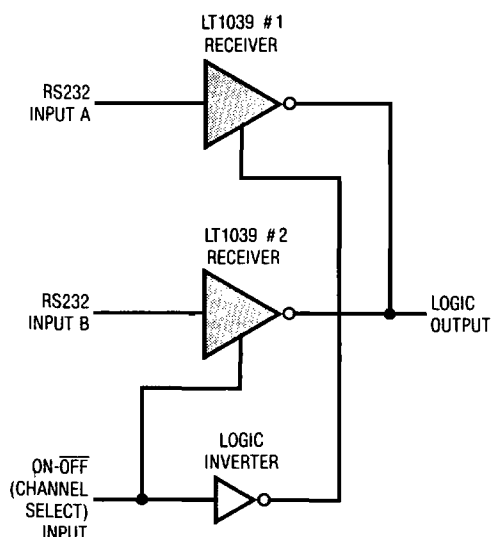

Sharing a Transmitter Line

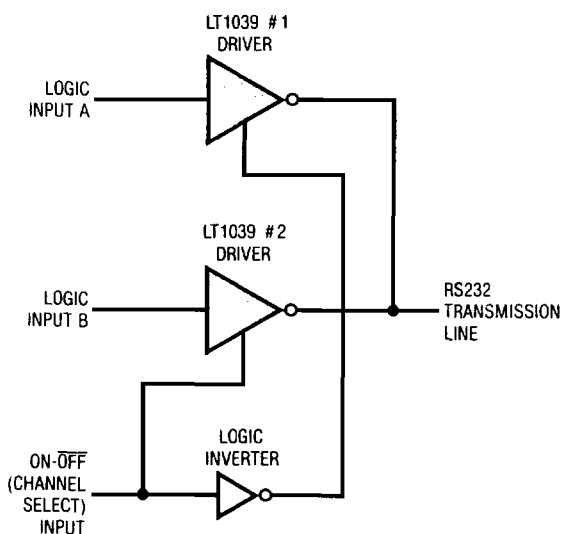

Transceiver

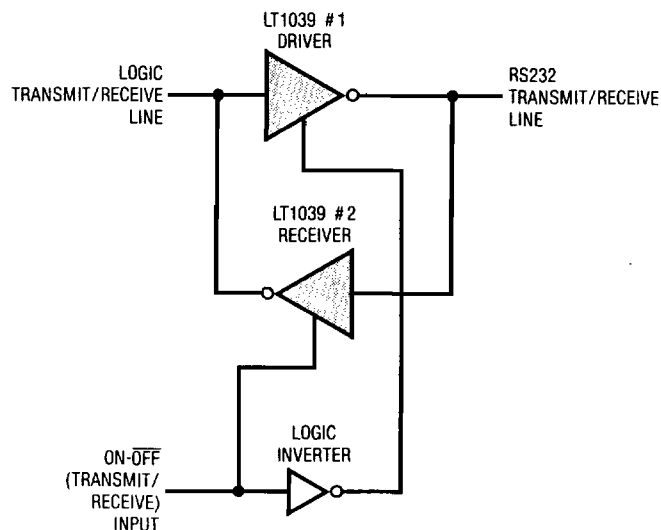

APPLICATION HINTS

To protect against receiver input overloads in excess of $\pm 30V$, a voltage clamp can be placed on the data line and still maintain RS232 compatibility.

The receiver input impedance of the LT1039 is nominally $30k\Omega$. For applications requiring a $5k\Omega$ input impedance, a $5.6k\Omega$ resistor can be connected from the receiver input to ground.

Driver inputs should not be allowed to float. Any unused inputs should be tied to V_{CC} .

The bias pin is used to "keep alive" one receiver while in the SHUTDOWN mode (all other circuitry being inactive). This allows a system to be in SHUTDOWN and still have one active receiver for transferring data. It can also be used to make an RS232 compatible SHUTDOWN control line. Driving the bias pin low through a resistance of $24k\Omega$ to $30k\Omega$ keeps the receiver active. Do not drive the bias pin directly from a logic output without the series resistor. An unused bias pin should be left open.

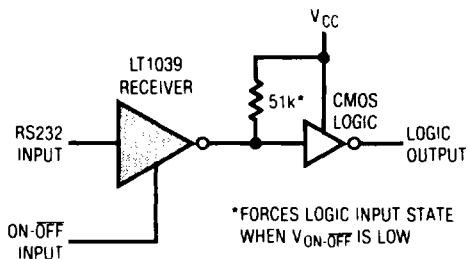

Keeping Alive One Receiver while in SHUTDOWN

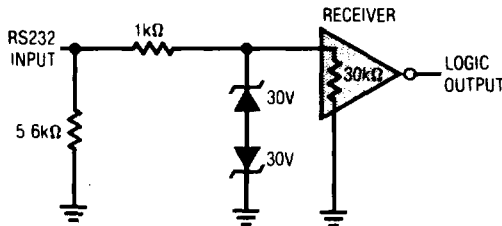
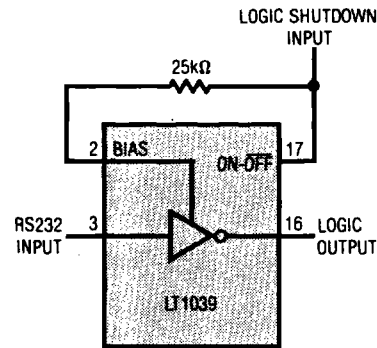

RS232 Compatible SHUTDOWN Control Line

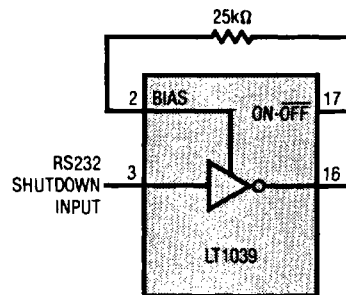
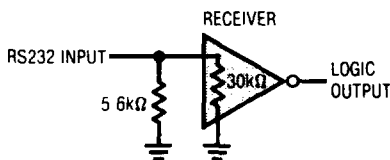

10

PACKAGE DESCRIPTION Dimensions in inches (millimeters) unless otherwise noted.

J16 Package Ceramic DIP

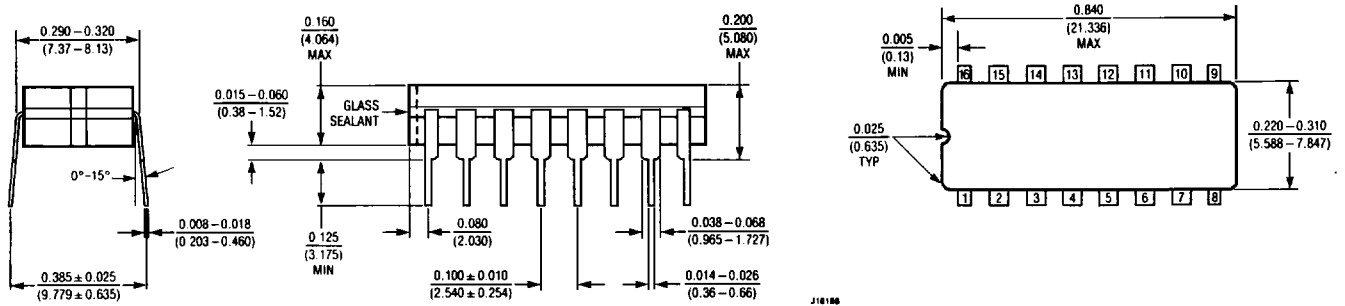

	T_{jmax}	θ_{ja}	θ_{jc}
LT1039MJ16	150°C	100°C/W	30°C/W
LT1039CJ16	150°C	100°C/W	30°C/W

J18 Package Ceramic DIP

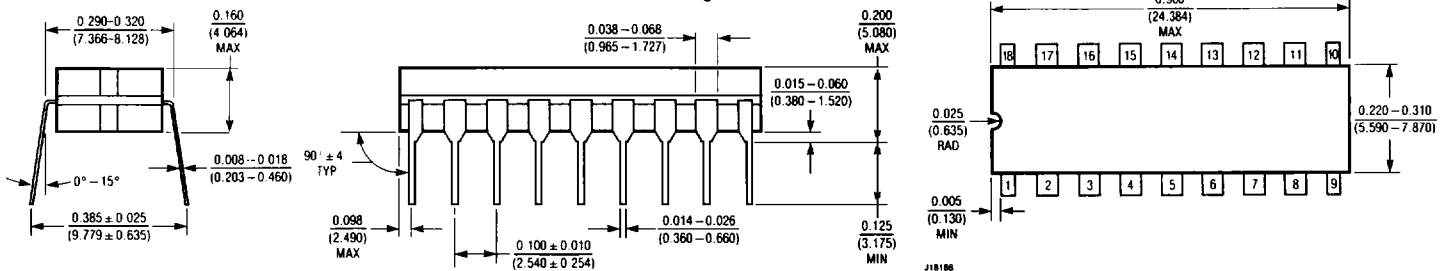

	T_{jmax}	θ_{ja}	θ_{jc}
LT1039MJ	150°C	100°C/W	40°C/W
LT1039CJ	150°C	100°C/W	40°C/W

N16 Package Plastic DIP

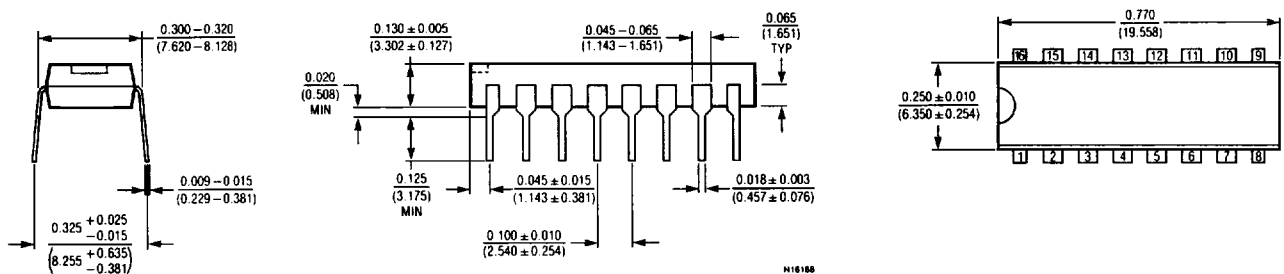

	T_{jmax}	θ_{ja}	θ_{jc}
LT1039CN16	85°C	140°C/W	50°C/W

N18 Package Plastic DIP

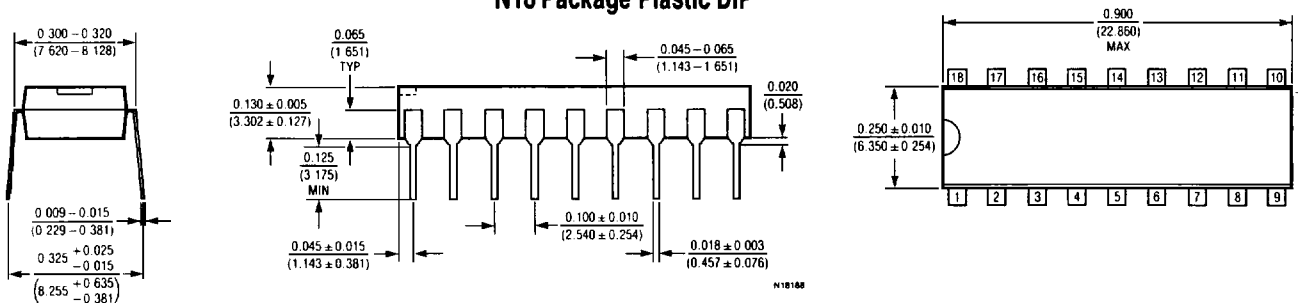

	T_{jmax}	θ_{ja}	θ_{jc}
LT1039CN	85°C	120°C/W	50°C/W