

# High Performance Triple Universal Filter Building Block

## FEATURES

- Up to 6th Order Filter Functions with a Single 20-Pin 0.3" Wide Package
- Center Frequency Range up to 35kHz
- $f_0 \times Q$  Product up to 1MHz
- *Guaranteed* Center Frequency and Q Accuracy Over Temperature
- *Guaranteed* Low Offset Voltages Over Temperature
- 90dB Signal-to-Noise Ratio
- Filter Operates from Single 4.7V Supply and up to  $\pm 8V$  Supplies
- *Guaranteed* Filter Specifications with  $\pm 5V$  Supply and  $\pm 2.37V$  Supply
- Low Power Consumption with Single 5V Supply
- Clock Inputs T<sup>2</sup>L and CMOS Compatible

## APPLICATIONS

- High Order, Wide Frequency Range Bandpass, Lowpass, Notch Filters
- Low Power Consumption, Single 5V Supply, Clock-Tunable Filters
- Tracking Filters
- Antialiasing Filters

LTCMOS™ is a trademark of Linear Technology Corp.

## DESCRIPTION

The LTC1061 consists of three high performance, universal filter building blocks. Each filter building block together with an external clock and 2 to 5 resistors can produce various second order functions which are available at its three output pins. Two out of three always provide low-pass and bandpass functions while the third output pin can produce highpass or notch or allpass. The center frequency of these functions can be tuned with an external clock or an external clock and a resistor ratio. For  $Q < 5$ , the center frequency ranges from 0.1Hz to 35kHz. For  $Q$ s of 10 or above, the center frequency ranges from 0.1Hz to 28kHz.

The LTC1061 can be used with single or dual supplies ranging from  $\pm 2.37V$  to  $\pm 8V$  (or 4.74V to 16V). When the filter operates with supplies of  $\pm 5V$  and above, it can handle input frequencies up to 100kHz.

The LTC1061 is compatible with the LTC1059 single universal filter and the LTC1060 dual. Higher than 6th order functions can be obtained by cascading the LTC1061 with the LTC1059 or LTC1060. Any classical filter realization can be obtained.

The LTC1061 is manufactured by using Linear Technology's enhanced LTCMOS™ silicon gate process.

## TYPICAL APPLICATION

6th Order, Clock-Tunable, 0.5dB Ripple Chebyshev BP Filter

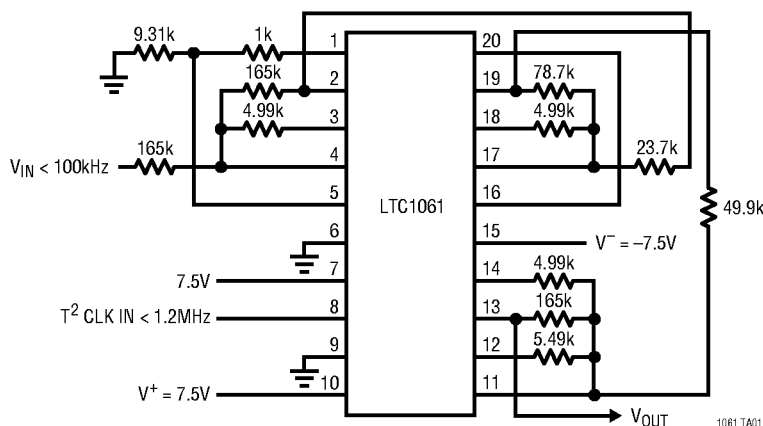

Amplitude Response

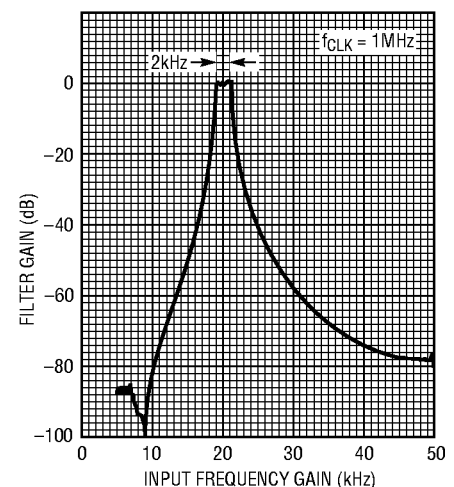

LTC1061 • TA02

## ABSOLUTE MAXIMUM RATINGS

Supply Voltage .....	18V
Power Dissipation .....	500mW
Operating Temperature Range	
LTC1061AC, LTC1061C .....	$-40^{\circ}\text{C} \leq T_A \leq 85^{\circ}\text{C}$
LTC1061AM, LTC1061M .....	$-55^{\circ}\text{C} \leq T_A \leq 125^{\circ}\text{C}$
Storage Temperature Range .....	$-65^{\circ}\text{C}$ to $150^{\circ}\text{C}$
Lead Temperature (Soldering, 10 sec.) .....	300°C

## PACKAGE/ORDER INFORMATION

TOP VIEW		ORDER PART NUMBER
LP <sub>A</sub> 1	20 LP <sub>B</sub>	LTC1061AMJ LTC1061MJ LTC1061ACJ LTC1061CJ LTC1061ACN LTC1061CN LTC1061CS
BP <sub>A</sub> 2	19 BP <sub>B</sub>	
NA 3	18 N <sub>B</sub>	
INV <sub>A</sub> 4	17 INV <sub>B</sub>	
S1 <sub>A</sub> 5	16 S1 <sub>B</sub>	
AGND 6	15 V <sup>-</sup>	
50/100/HOLD 7	14 LP <sub>C</sub>	
CLK 8	13 BP <sub>C</sub>	
LS <sub>H</sub> 9	12 HP <sub>C</sub>	
V <sup>+</sup> 10	11 INV <sub>C</sub>	
J PACKAGE 20-LEAD CERAMIC DIP	N PACKAGE 20-LEAD PLASTIC DIP	
S PACKAGE 20-LEAD PLASTIC SOL		
T <sub>JMAX</sub> = 125°C, θ <sub>JA</sub> = 100°C/W (J)		
T <sub>JMAX</sub> = 100°C, θ <sub>JA</sub> = 100°C/W (N)		
T <sub>JMAX</sub> = 100°C, θ <sub>JA</sub> = 85°C/W (S)		

Consult factory for Industrial grade parts

## ELECTRICAL CHARACTERISTICS

(Complete Filter) V<sub>S</sub> = ±5V, T<sub>A</sub> = 25°C, T<sup>2</sup>L clock input level, unless otherwise specified.

PARAMETER	CONDITIONS	MIN	TYP	MAX	UNITS
Center Frequency Range, f <sub>0</sub>	f <sub>0</sub> × Q ≤ 175kHz, Mode 1, V <sub>S</sub> = ±7.5V		0.1–35k		Hz
	f <sub>0</sub> × Q ≤ 1.6MHz, Mode 1, V <sub>S</sub> = ±7.5V		0.1–25k		Hz
	f <sub>0</sub> × Q ≤ 75kHz, Mode 3, V <sub>S</sub> = ±7.5V		0.1–25k		Hz
	f <sub>0</sub> × Q ≤ 1MHz, Mode 3, V <sub>S</sub> = ±7.5V		0.1–17k		Hz
Input Frequency Range			0–200k		Hz
Clock-to-Center Frequency Ratio, f <sub>CLK</sub> /f <sub>0</sub>	Sides A, B: Mode 1, R1 = R3 = 50k R2 = 5k, Q = 10, f <sub>CLK</sub> = 250kHz Pin 7 High.	●		50±0.6%	
		●		50±1.2%	
LTC1061A LTC1061	Side C: Mode 3, R1 = R3 = 50k R2 = R4 = 5k, f <sub>CLK</sub> = 250kHz Same as Above, Pin 7 at Mid-Supplies, f <sub>CLK</sub> = 500kHz	●		100±0.6%	
		●		100±1.2%	
Clock-to-Center Frequency Ratio, Side-to-Side Matching				1.2%	
Q Accuracy	Sides A, B, Mode 1				
	Side C, Mode 3	●	±2	5	%
LTC1061A LTC1061	f <sub>0</sub> × Q ≤ 50kHz, f <sub>0</sub> × ≤ 5kHz	●	±3	5	%
f <sub>0</sub> Temperature Coefficient	Mode 1, 50:1, f <sub>CLK</sub> < 300kHz		±1		ppm/°C
Q Temperature Coefficient	Mode 1, 100:1, f <sub>CLK</sub> < 500kHz		±5		ppm/°C
	Mode 3, f <sub>CLK</sub> < 500kHz		±5		ppm/°C

## ELECTRICAL CHARACTERISTICS

(Complete Filter)  $V_S = \pm 5V$ ,  $T_A = 25^\circ C$ ,  $T^2L$  clock input level, unless otherwise specified.

PARAMETER	CONDITIONS		MIN	TYP	MAX	UNITS
DC Offset Voltage		●				
$V_{OS1}$ , Figure 23		●		2	15	mV
$V_{OS2}$	$f_{CLK} = 250kHz, 50:1$	●		3	30	mV
$V_{OS2}$	$f_{CLK} = 500kHz, 100:1$	●		6	60	mV
$V_{OS3}$ , LTC1061CN, ACN/LTC1061CS	$f_{CLK} = 250kHz, 50:1$	●		3	20/25	mV
$V_{OS3}$ , LTC1061CN, ACN/LTC1061CS	$f_{CLK} = 500kHz, 100:1$	●		6	40/50	mV
Clock Feedthrough	$f_{CLK} < 1MHz$			0.4		mV <sub>RMS</sub>
Maximum Clock Frequency	Mode 1, $Q < 5$ , $V_S \geq \pm 5$			2.5		MHz
Power Supply Current		●	6	8	11	mA
					15	mA

(Complete Filter)  $V_S = \pm 2.37V$ ,  $T_A = 25^\circ C$ , unless otherwise specified.

Center Frequency Range, $f_0$	$f_0 \times Q \leq 120kHz$ , Mode 1, 50:1 $f_0 \times Q \leq 120kHz$ , Mode 3, 50:1			0.1–12k 0.1–10k		Hz Hz
Input Frequency Range				0–20k		Hz
Clock-to-Center Frequency Ratio	50:1, $f_{CLK} = 250kHz$ , $Q = 10$					
LTC1061A	Sides A, B: Mode 1			50±0.6%		
LTC1061	Side C, Mode 3, 250kHz			50±1.0%		
LT1061A	100:1, $f_{CLK} = 500kHz$ , $Q = 10$			100±0.6%		
LT1061	Sides A, B: Mode 1 Side C: Mode 3			100±1.0%		
Q Accuracy	Same as Above			±2 ±3		% %
LTC1061A						
LTC1061						
Maximum Clock Frequency				700		kHz
Power Supply Current				4.5	6	mA

(Internal Op Amps)  $T_A = 25^\circ C$ , unless otherwise specified.

Supply Voltage Range			±2.37		±9	V
Voltage Swings						
LTC1061A	$V_S = \pm 5V$ , $R_L = 5k$ (Pins 1,2,13,14,19,20)		±4.0	±4.2		V
LTC1061	$V_S = \pm 5V$ , $R_L = 3.5k$ (Pins 3,12,18)	●	±3.8	±4.2		V
LTC1061, LTC1061A			±3.6			V
Output Short-Circuit Current						
Source/Sink	$V_S = \pm 5V$			40/3		mA
DC Open-Loop Gain	$V_S = \pm 5V$ , $R_L = 5k$			80		dB
GBW Product	$V_S = \pm 5V$			3		MHz
Slew Rate	$V_S = \pm 5V$			7		V/ $\mu s$

The ● denotes the specifications which apply over the full operating temperature range.

TYPICAL PERFORMANCE CHARACTERISTICS

Mode 1, Mode 3 ( $f_{CLK}/f_0$ ) Deviation vs Q

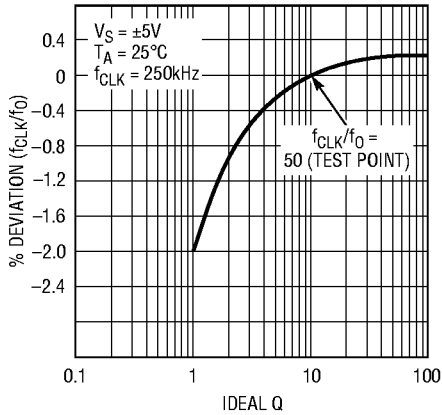

LTC1061 G01

Mode 1, Mode 3 ( $f_{CLK}/f_0$ ) Deviation vs Q

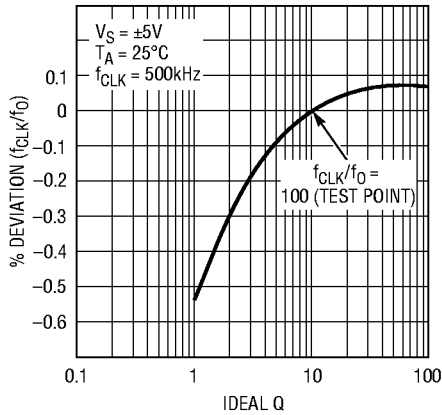

LTC1061 G02

Mode 3: Deviation of ( $f_{CLK}/f_0$ ) with Respect to Q = 10 Measurement

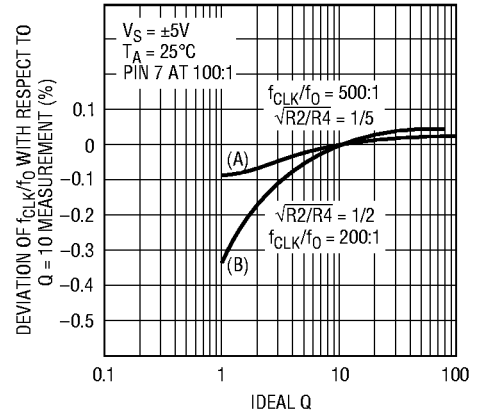

LTC1061 G03

Mode 1: ( $f_{CLK}/f_0$ ) = 50:1

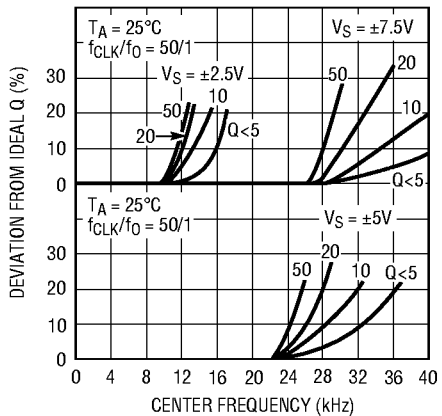

1061 G04

Mode 1: ( $f_{CLK}/f_0$ ) = 100:1

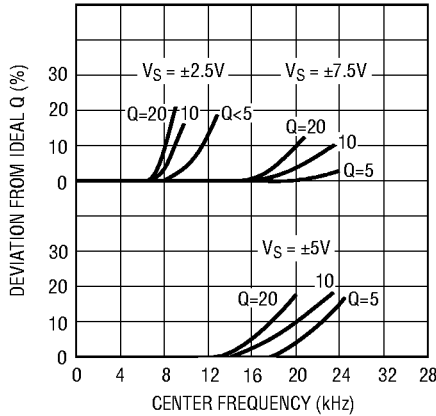

1061 G05

Mode 3: ( $f_{CLK}/f_0$ ) = 50:1

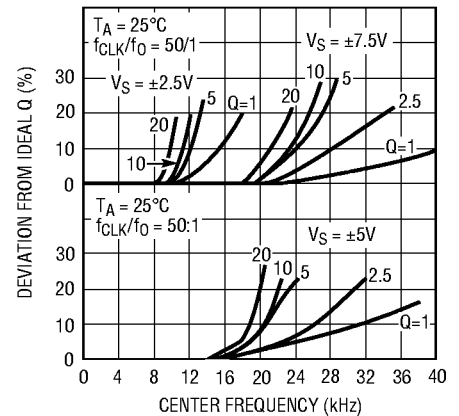

1061 G06

Mode 3: ( $f_{CLK}/f_0$ ) = 100:1

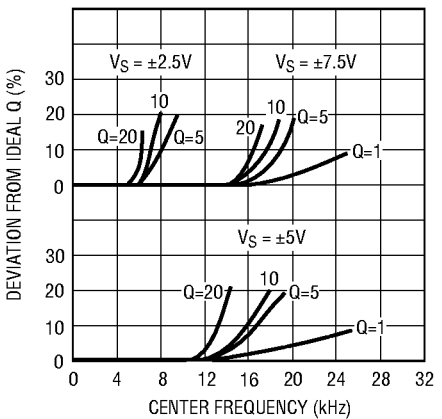

1061 G07

$f_{CLK}/f_0$  vs  $f_0$

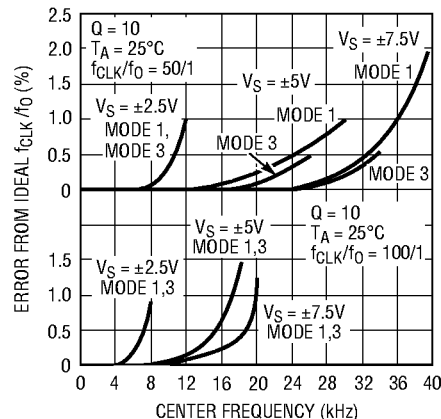

1061 G08

Power Supply Current vs Supply Voltage

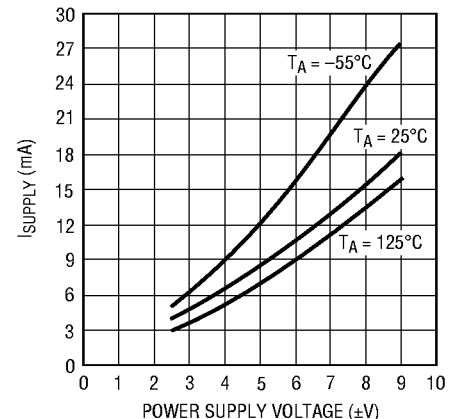

1061 G09

## BLOCK DIAGRAM

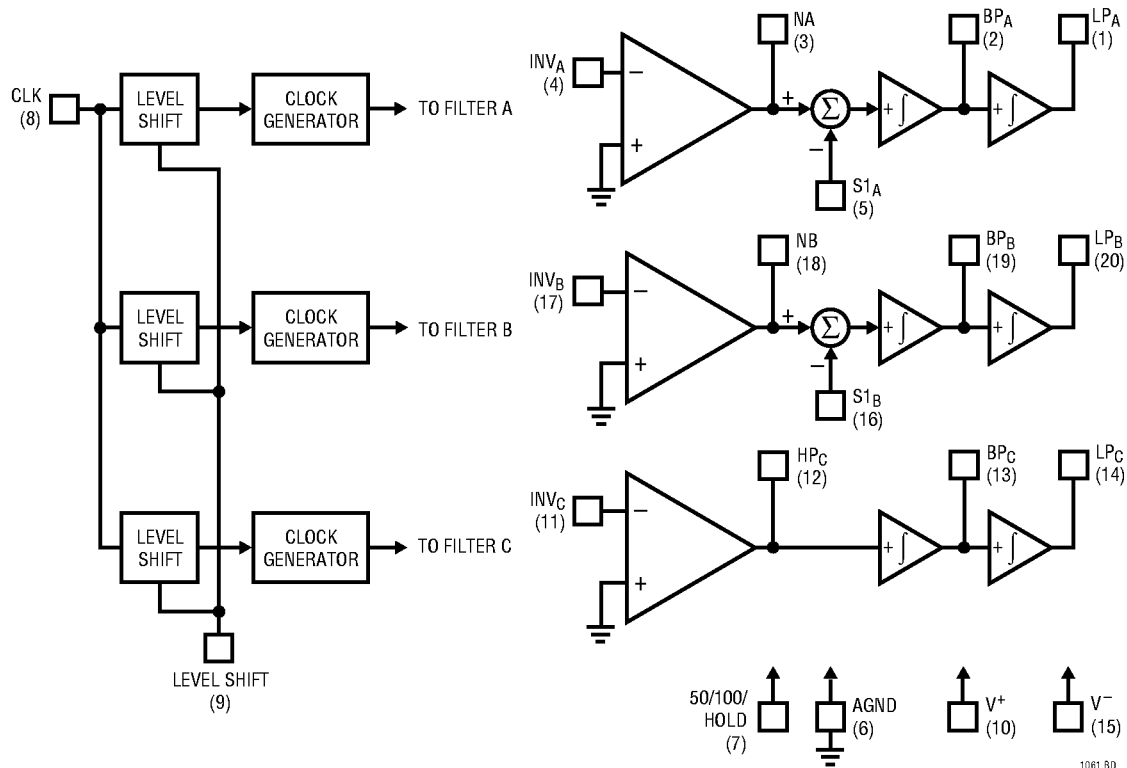

## PIN DESCRIPTION AND APPLICATION HINTS

### Power Supplies (Pins 10, 15)

They should be bypassed with 0.1 $\mu$ F disc ceramic. Low noise, nonswitching, power supplies are recommended. The device operates with a single 5V supply, Figure 1, and with dual supplies. The absolute maximum operating power supply voltage is  $\pm 9$ V.

### Clock and Level shift (Pins 8, 9)

When the LTC1061 operates with symmetrical dual supplies the level shift Pin 9 should be tied to analog ground. For single 5V supply operation, the level shift pin should be tied to Pin 15 which will be the system ground. The typical logic threshold levels of the clock pin are as follows: 1.65V above the level shift pin for  $\pm 5$ V supply operation, 1.75V for  $\pm 7.5$ V and above, and 1.4V for single 5V supply operation. The logic threshold levels vary  $\pm 100$ mV over the full military temperature range. The recommended duty cycle of the input clock is 50% although for clock

frequencies below 500kHz the clock “on” time can be as low as 300ns. The maximum clock frequency for  $\pm 5$ V supplies and above is 2.4MHz.

### S1<sub>A</sub>, S1<sub>B</sub> (Pins 5, 16)

These are voltage input pins. If used, they should be driven with a source impedance below 5k $\Omega$ . When they are not used, they should be tied to the analog ground Pin 6.

### AGND (Pin 6)

When the LTC1061 operates with dual supplies, Pin 6 should be tied to system ground. When the LTC1061 operates with a single positive supply, the analog ground pin should be tied to 1/2 supply, Figure 1. The positive input of all the internal op amps, as well as the common reference of all the internal switches, are internally tied to the analog ground pin. Because of this, a “clean” ground is recommended.

## PIN DESCRIPTION AND APPLICATION HINTS

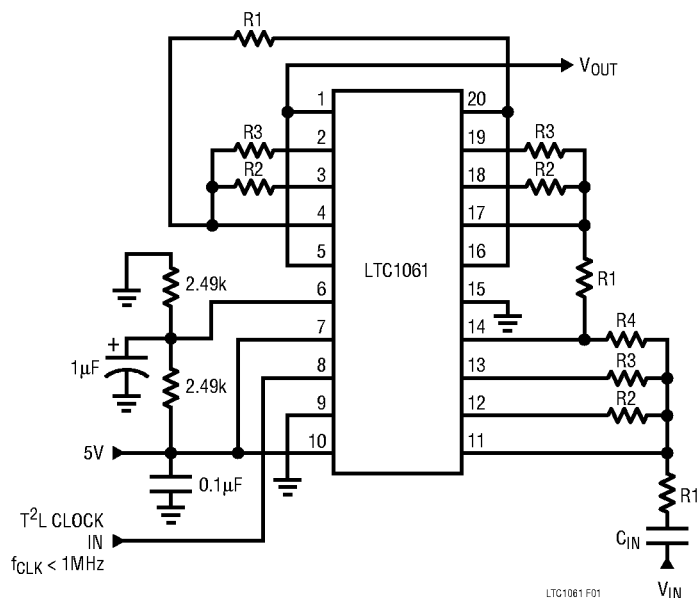

Figure 1. the 6th Order LP Butterworth Filter of Figure 5 Operating with a Single 5V Supply.

### 50/100/Hold (Pin 7)

By tying Pin 7 to  $V^+$ , the filter operates with a clock-to-center frequency internally set at 50:1. When Pin 7 is at mid-supplies, the filter operates with a 100:1 clock-to-center frequency ratio. Table 1 shows the allowable variation of the potential at Pin 7 when the 100:1 mode is sought.

When Pin 7 is shorted to the negative supply pin, the filter operation is stopped and the bandpass and lowpass output act as a sample-and-hold circuit holding the last sample of the input voltage. The hold step is around 2mV and the droop rate is 150µV/sec.

Table 1

TOTAL POWER SUPPLY (V)	VOLTAGE RANGE OF PIN 7 FOR 100:1 OPERATION (V)
5	2.5 ± 0.5
10	5 ± 1
15	7.5 ± 1.5

### Clock Feedthrough

This is defined as the amplitude of the clock frequency appearing at the output pins of the device, Figure 2. Clock feedthrough is measured with all three sides of the LTC1061 connected as filters. The clock feedthrough mainly depends on the magnitude of the power supplies and it is independent from the input clock levels, clock frequency and modes of operation.

The Table 2 illustrates the typical clock feedthrough numbers for various power supplies.

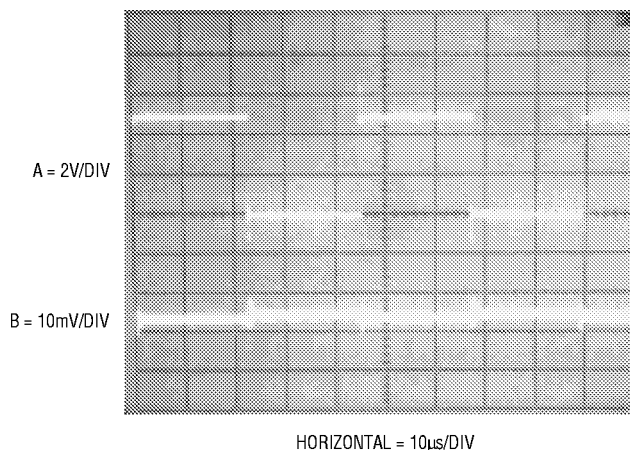

Figure 2. Typical Clock Feedthrough of the LTC1061 Operating with ±5V Supplies. Top Trace is the Input Clock Swinging 0V to 5V and Bottom Trace is One of the Lowpass Outputs with Zero or DC Input Signals.

Table 2

POWER SUPPLY (V)	CLOCK FEEDTHROUGH ( $V_{RMS}$ )
±2.5	0.2
±5	0.4
±8	0.8

### Definition of Filter Functions

Refer to LTC1060 data sheet.

# MODES OF OPERATION

## Description and Applications

**1. Primary Modes:** There are two basic modes of operation, Mode 1 and Mode 3. In Mode 1, the ratio of the external clock frequency to the center frequency of each 2nd order section is internally fixed at 50:1 or 100:1. In Mode 3, this ratio can be adjusted above or below 50:1 or 100:1. The side C of the LTC1061 can be connected only in Mode 3. Figure 3 illustrates Mode 1 providing 2nd order notch, lowpass, and bandpass outputs (for definition of filter functions, refer to the LTC1060 data sheet). Mode 1 can be used to make high order Butterworth lowpass filters; it can also be used to make low Q notches and for cascading 2nd order bandpass functions tuned at the same center frequency and with unity-gain. Mode 3,

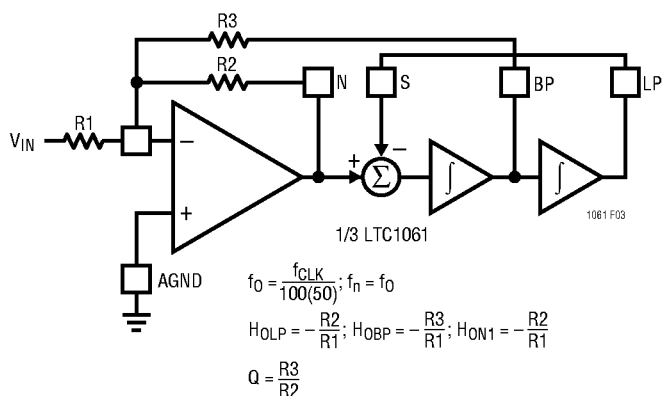

Figure 3. Mode 1: 2nd Order Filter Providing Notch, Bandpass, Lowpass

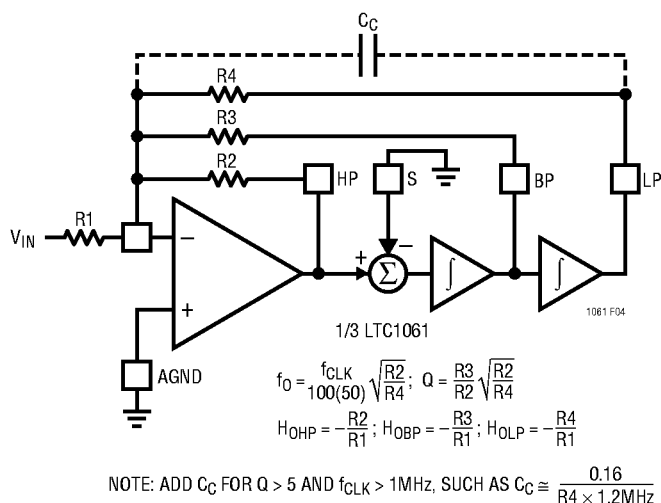

Figure 4. Mode 3: 2nd Order Filter Providing Highpass, Bandpass, Lowpass

Figure 4, is the classical state variable configuration providing highpass, bandpass and lowpass 2nd order filter functions.

Since the input amplifier is within the resonant loop, its phase shift affects the high frequency operation of the filter and therefore, Mode 3 is slower than Mode 1. Mode 3 can be used to make high order all-pole bandpass, lowpass, highpass and notch filters. Mode 3 as well as Mode 1 is a straightforward mode to use and the filter's dynamics can easily be optimized. Figure 5 illustrates a 6th order lowpass Butterworth filter operating with up to 40kHz cutoff frequency and with up to 200kHz input frequency. Sides A, B are connected in Mode 1 while side C is connected in Mode 3. The lower Q section was placed in side C, Mode 3, to eliminate any early Q enhancement. This could happen when the clock approaches 2MHz. The measured frequency response is shown in Figure 6. The attenuation floor is limited by the crosstalk between the three different sections operating with a clock frequency above 1MHz. The measured wideband noise was  $150\mu\text{V}_{RMS}$ . For limited temperature range the filter of Figure 5 works up to 2.5MHz clock frequency thus yielding a 50kHz cutoff.

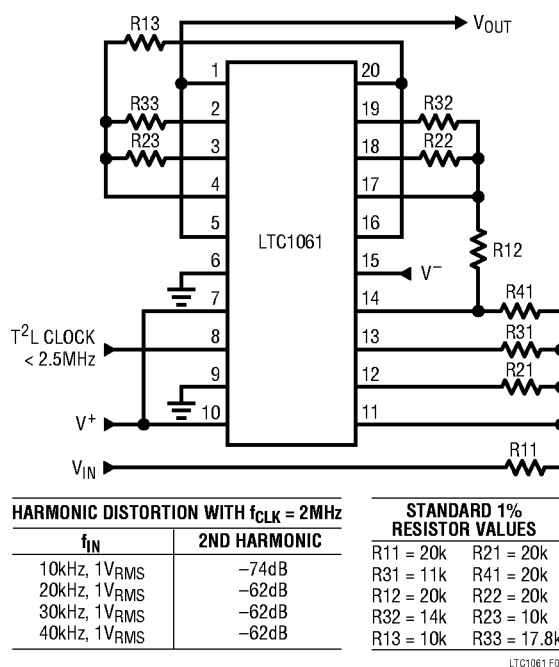

Figure 5. 6th Order Butterworth Lowpass Filter with Cutoff Frequency up to 45kHz

# MODES OF OPERATION

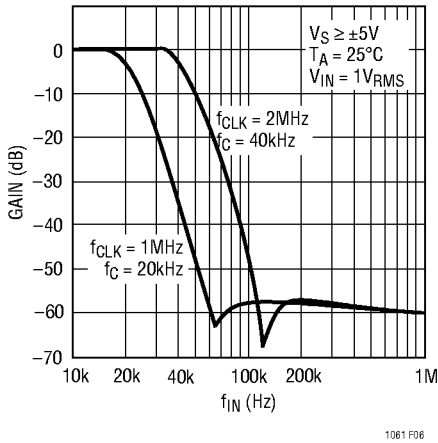

Figure 6. Measures Frequency Response of the Lowpass Butterworth Filter of Figure 3.

**2. Secondary Modes: Mode 1b** – It is derived from Mode 1. In Mode 1b, Figure 7, two additional resistors, R5 and R6, are added to attenuate the amount of voltage fed back from the lowpass output into the input of the S<sub>A</sub> (S<sub>B</sub>) switched capacitor summer. This allows the filter clock-to-center frequency ratio to be adjusted beyond 50:1 (or 100:1). Mode 1b still maintains the speed advantages of Mode 1. Figure 8 shows the 3 lowpass sections of the LTC1061 in cascade resulting in a Chebyshev lowpass filter. The side A of the IC is connected in Mode 1b to provide the first resonant frequency below the cutoff frequency of the filter. The practical ripple, obtained by using a non-A version of the LTC1061 and 1% standard resistor values, was 0.15dB. For this 6th order lowpass,

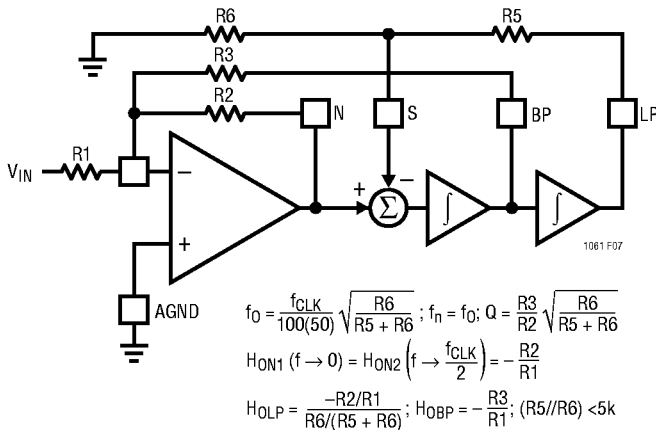

Figure 7. Mode 1b: 2nd Order Filter Providing Notch, Bandpass, Lowpass

the textbook Qs and center frequencies normalized to the ripple bandwidth are: Q<sub>1</sub> = 0.55, f<sub>01</sub> = 0.71, Q<sub>2</sub> = 1.03, F<sub>02</sub> = 0.969, Q<sub>3</sub> = 3.4, F<sub>03</sub> = 1.17. The design was done with speed in mind. The higher (Q<sub>3</sub>, F<sub>03</sub>) section was in Mode 1 and placed in the side B of the LTC1061. The remaining two center frequencies were then normalized with respect to the center frequency of side B; this changes the ratio of clock-to-cutoff frequency from 50:1 to 50 × 1.17 = 58.5:1. As shown in Figure 9, the maximum cutoff frequency is about 33kHz. The total wideband output noise is 220μV<sub>RMS</sub> and the measured output DC offset voltage is 60mV.

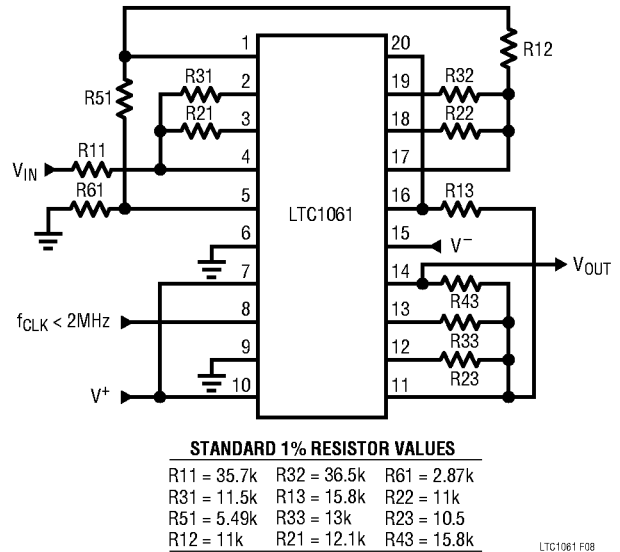

Figure 8. 6th Order Chebyshev, Lowpass Filter Using 3 Different Modes of Operation for Speed Optimization

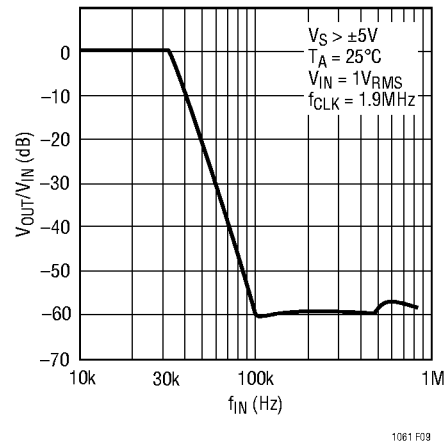

Figure 9. Amplitude Response of the 6th Order Chebyshev Lowpass Filter of Figure 8



## MODES OF OPERATION

Another example of Mode 1b is illustrated on the front page of the data sheet. The cascading sequence of this 6th order bandpass filter is shown in block diagram form, Figure 10a. the filter is geometrically centered around the side B of the LTC1061 connected in Mode 1. This dictates a clock-to-center frequency ratio of 50:1 or 100:1. The side A of the IC operates in Mode 1b to provide the lower center frequency of 0.95 and still share the same clock with the rest of the filter. With this approach the bandpass filter can

operate with center frequencies up to 24kHz. The speed of the filter could be further improved by using Mode 1 to lock the higher resonant frequency of 1.05 and higher Q or 31.9 to the clock, Figure 10b, thus changing the clock to center frequency ratio to 52.6:1.

**Mode 3a** – This is an extension of Mode 3 where the highpass and lowpass outputs are summed through two external resistors  $R_h$  and  $R_l$  to create a notch, Figure 11. Mode 3a is very versatile because the notch frequency can be higher or lower than the center frequency of the 2nd order section. The external op amp of Figure 11 is not always required. When cascading the sections of the LTC1061, the highpass and lowpass outputs can be summed directly into the inverting input of the next section. Figure 12 shows an LTC1061 providing a 6th order elliptic bandpass or notch response. Sides C and B are connected in Mode 3a while side A is connected in Mode 1 and uses only two resistors. The resulting filter response is then geometrically symmetrical around either the center frequency of side A (for bandpass responses) or the notch frequency of side A (for notch responses).

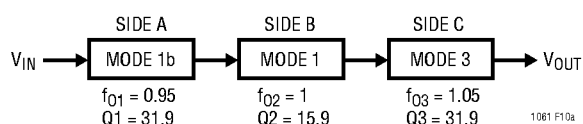

Figure 10a. Cascading Sequence of the Bandpass Filter Shown on the Front Page, with  $(f_{CLK}/f_0) = 50:1$  or  $100:1$

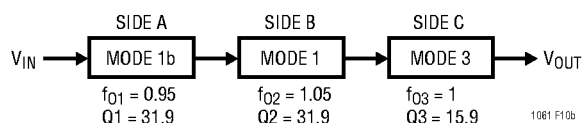
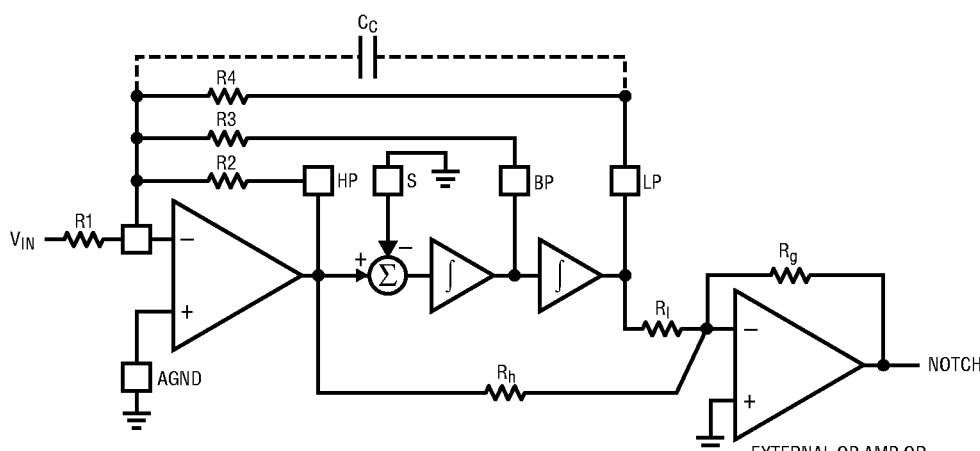

Figure 10b. Cascading Sequence of the Same Filter for Speed Optimization, and with  $(f_{CLK}/f_0) = 52.6:1$



$$f_0 = \frac{f_{CLK}}{100(50)} \sqrt{\frac{R_2}{R_4}}; f_n = \frac{f_{CLK}}{100(50)} \sqrt{\frac{R_h}{R_l}}; H_{OHP} = -\frac{R_2}{R_1}; H_{OBP} = -\frac{R_3}{R_1}; H_{OLP} = -\frac{R_4}{R_1}$$

$$H_{ON1}(f \rightarrow 0) = \frac{R_g}{R_l} \times \frac{R_4}{R_1}; H_{ON2}(f \rightarrow \frac{f_{CLK}}{2}) = \frac{R_g}{R_h} \times \frac{R_2}{R_1}; H_{ON}(f = f_0) = Q \left( \frac{R_g}{R_l} H_{OLP} - \frac{R_g}{R_h} H_{OHP} \right)$$

$$Q = \frac{R_3}{R_2} \sqrt{\frac{R_2}{R_4}}$$

NOTE: FOR  $Q > 5$  AND  $f_{CLK} > 1\text{MHz}$ , ADD  $C_C$  SUCH AS  $C_C \cong \frac{0.16}{R_4 \times 1.2\text{MHz}}$

Figure 11. Mode 3a: 2nd Order Filter Providing Highpass, Bandpass, Lowpass, Notch

# MODES OF OPERATION

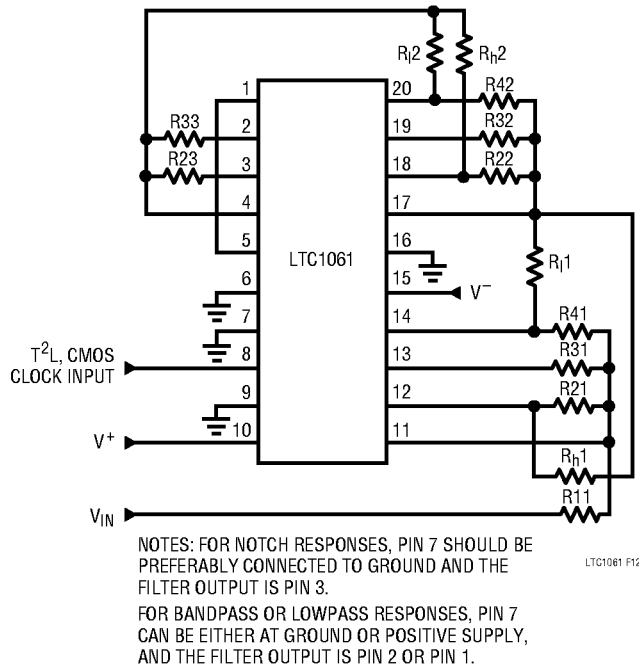

**Figure 12. 6th Order Elliptic Bandpass, Lowpass or Notch Topology**

center frequencies,  $Q_s$ , and notch frequencies are ( $f_{01} = 0.969$ ,  $Q_1 = 54.3$ ,  $f_{n1} = 0.84$ ,  $f_{02} = 1.031$ ,  $Q_2 = 54.3$ ,  $f_{n2} = 1.187$ ,  $f_{03} = 1$ ,  $Q_3 = 26.2$ ). The output of the filter is the BP output of Side A, Pin 2.

Lowpass filters with stopband notches can also be realized by using Figure 12 provided that 6th order lowpass filter approximations with 2 stopband notches can be synthesized. Literature describing elliptic double terminated (RLC)

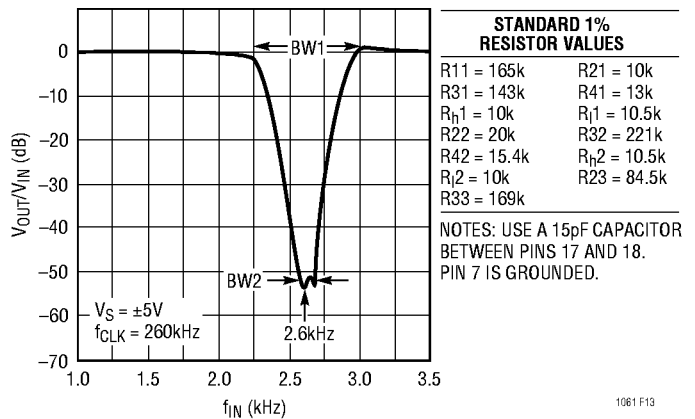
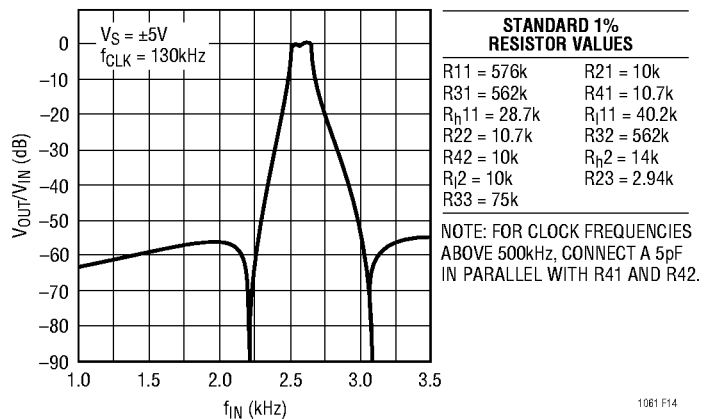

**Figure 13. Resistor Values and Amplitude Response of Figure 12 Topology. The Notch is Centered at 2600Hz.**

Figure 13 shows the measured frequency response of the circuit Figure 12 configured to provide a notch function. The filter output is taken out of pin 3. The resistor values are standard 1%.

The ratio of the 0dB width, BW1, to the notch width BW2, is 5:1 and matches the theoretical design value. The measured notch depth was -53dB versus -56dB theoretical and the clock-to-center notch frequency ratio is 100:1.

Figure 14 shows the measured frequency response of the circuit topology, Figure 12, but with pole/zero locations configured to provide a high Q, 6th order elliptic bandpass filter operating with a clock-to-center frequency ratio of 50:1 or 100:1. The theoretical passband ripple, stopband attenuation and stopband to ripple bandwidth ratio are 0.5dB, 56dB, 5:1 respectively. The obtained results with 1% standard resistor values closely match the theoretical frequency response. For this application, the normalized



**Figure 14. Resistor Values and Amplitude Response of Figure 12 Topology. The Bandpass Filter is Centered Around 2600Hz when Operating with a 130kHz Clock.**

# MODES OF OPERATION

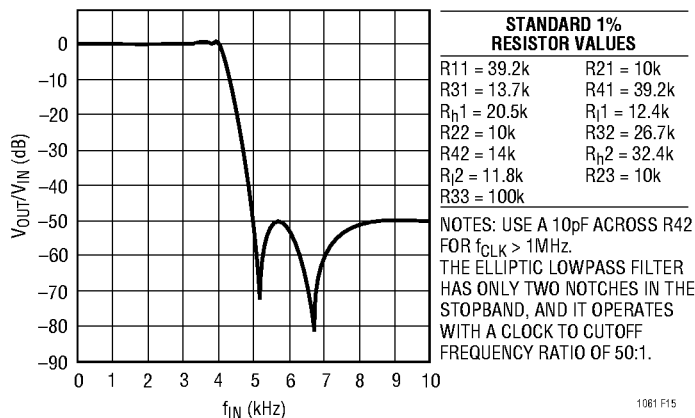

Figure 15. Resistor Values and Amplitude Response of the Topology of Figure 12.

passive ladder filters provide enough data to synthesize the above filters. The measured amplitude response of such a lowpass is shown in Figure 15 where the filter output is taken out of side A's Pin 1, Figure 12. The clock-to-center frequency ratio can be either 50:1 or 100:1 because the last stage of the LTC1061 operates in Mode 1 with a center frequency very close to the overall cutoff frequency of the lowpass filter.

In Figure 16, all three sides of the LTC1061 are connected in Mode 3a. This topology is useful for elliptic highpass and notch filters with clock-to-cutoff (or notch) frequency ratio higher than 100:1. This is often required to extend the allowed input signal frequency range and to avoid premature aliasing. Figure 16 is also a versatile, general purpose architecture providing 3 notches and 4 pole pairs, and there is no restriction on the location of the poles with respect to the notch frequencies. The drawbacks, when compared to Figure 12, are the use of an external op amp and the increased number of the required external resistors.

Figure 17 shows the measured frequency of a 6th order highpass elliptic filter operating with 250:1 clock-to-cutoff frequency ratio. With a 1MHz clock, for instance, the filter yields a 4kHz cutoff frequency, thus allowing an input frequency range beyond 100kHz. Band limiting can be easily added by placing a capacitor across the feedback resistor of the external op amp of Figure 16.

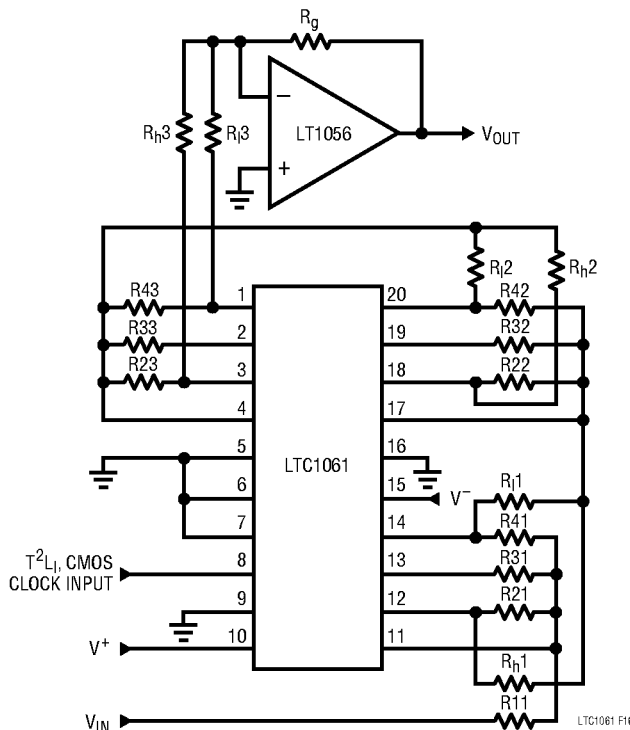

Figure 16. Using an External Op Amp to Connect all 3 Sides of the LTC1061 in Mode 3a.

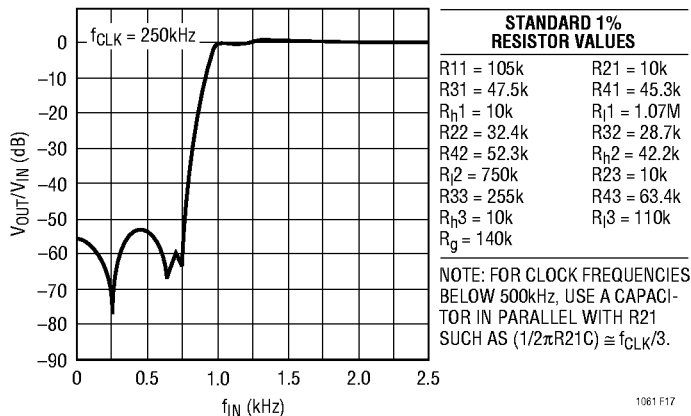

Figure 17. Measured Amplitude Response of the Topology of Figure 16, Configured to Provide a 6th Order Elliptic Highpass Filter Operating with a Clock-to-Cutoff Frequency Ratio of 250:1.

## MODES OF OPERATION

Figure 18 shows the plotted amplitude responses of a 6th order notch filter operating again with a clock-to-center notch frequency ratio of 250:1. The theoretical notch depth is 70dB and when the notch is centered at 1kHz its width is 50Hz. Two small, noncritical capacitors were used across the R21 and R22 resistors of Figure 16, to band-limit the first two highpass outputs such that the practical notch depth will approach the theoretical value. With these two fixed capacitors, the notch frequency can be swept within a 3:1 range.

When the circuit of Figure 16 is used to realize lowpass elliptic filters, a capacitor across  $R_g$  raises the order of the filter and at the same time eliminates any small clock feedthrough. This is shown in Figure 19 where the amplitude response of the filter is plotted for 3 different cutoff frequencies. When the clock frequency equals or exceeds 1MHz, the stopband notches lose their depth due to the finite bandwidth of the internal op amps and to the small crosstalk between the different sides of the LTC1061. The lowpass filter, however, does not lose its passband accuracy and it maintains nearly all of its attenuation slope. The theoretical performance of the 7th order lowpass filter of Figure 19 is 0.2dB passband ripple, 1.5:1 stopband-to-cutoff frequency ratio, and 73dB stopband attenuation. Without any tuning, the obtained results closely approximate the textbook response.

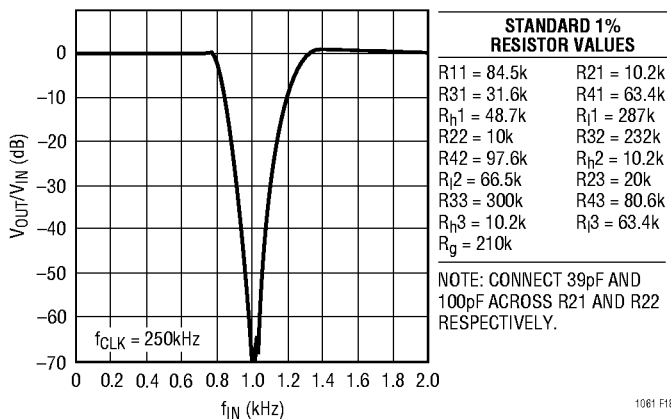
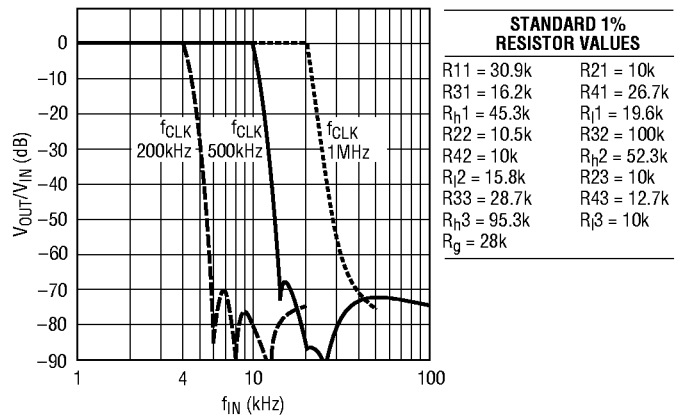

Figure 18. 6th Order Band Reject Filter Operating with a Clock-to-Center Notch Frequency Ratio of 250:1. The Ratio of 0dB to the -65dB Notch Width is 8:1.



NOTE: ADD A CAPACITOR C ACROSS  $R_g$  TO CREATE A 7TH ORDER LOWPASS SUCH AS  $(1/2\pi R_g C) = (\text{CUTOFF FREQUENCY}) \times 0.38$

1061 F19

Figure 19. Frequency Responses of a 7th Order Lowpass Elliptic Filter Realized with Figure 16 Topology.

**Mode 2** – This is a combination of Mode 1 and Mode 3, Figure 20. With Mode 2, the clock-to-center frequency ratio,  $f_{CLK}/f_0$ , is always less than 50:1 or 100:1. When compared to Mode 3 and for applications requiring 2nd order section with  $f_{CLK}/f_0$  slightly less than 100 or 50:1, Mode 2 provides less sensitivity to resistor tolerances. As in Mode 1, Mode 2 has a notch output which directly depends on the clock frequency and therefore the notch frequency is always less than the center frequency,  $f_0$ , of the 2nd order section.

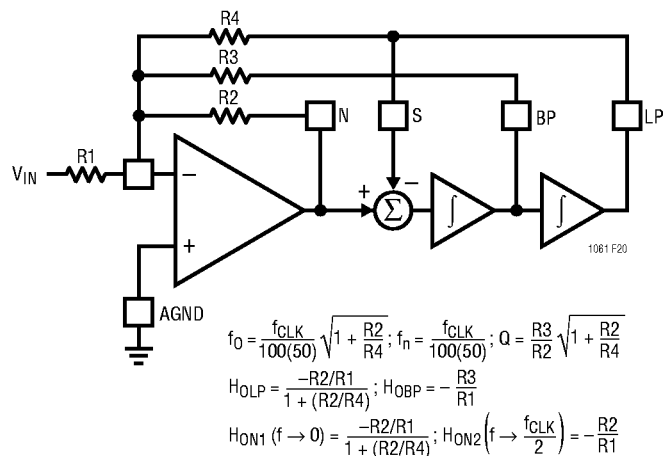

Figure 20. Mode 2: 2nd Order Filter Providing Notch, Bandpass, Lowpass.

## MODES OF OPERATION

Figure 21 shows the side A of the LTC1061 connected in Mode 2 while sides B and C are in Mode 3a. This topology can be used to synthesize elliptic bandpass, highpass and notch filters. The elliptic highpass of Figure 17 is synthesized again, Figure 22, but the clock is now locked onto the

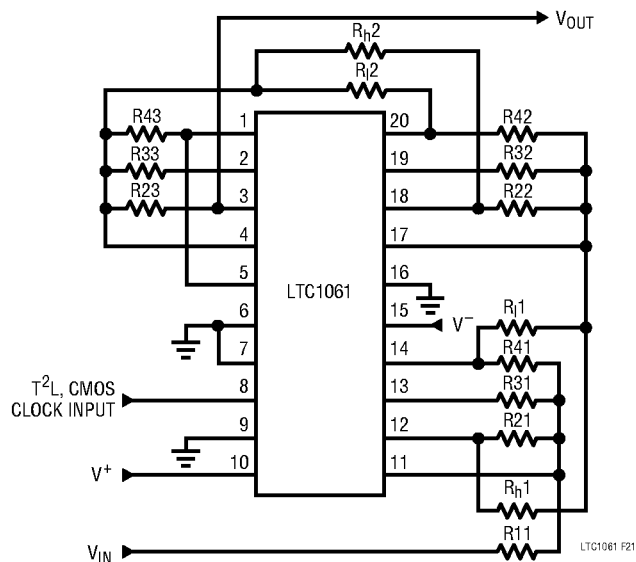

Figure 21. LTC1061 with Side A is Connected in Mode 2 While Side B, C are in Mode 3a. Topology is Useful for Elliptic Highpass, Notch and Bandpass Filters.

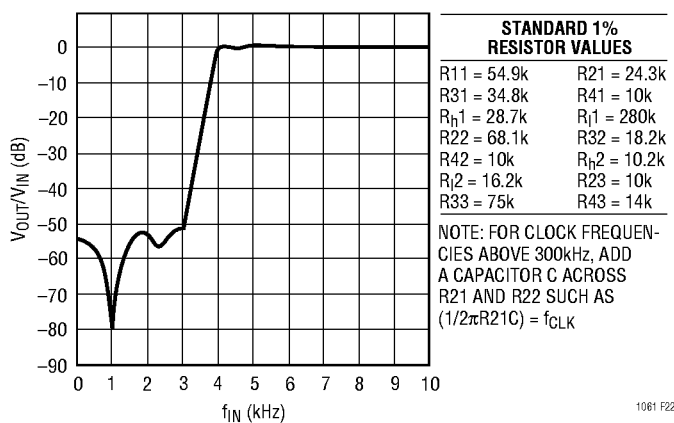

Figure 22. 6th Order Elliptic Highpass Filter Operating with a Clock-to-Cutoff Frequency Ratio of 75:1, and Using the Topology of Figure 21.

higher frequency notch provided by the side A of the LTC1061. As shown in Figure 22, the highpass corner frequency is 3.93kHz and the higher notch frequency is 3kHz while the filter operates with a 300kHz clock. The center frequencies, Qs, and notches of Figure 22, when normalized to the highpass cutoff frequency, are ( $f_{01} = 1.17$ ,  $Q_1 = 2.24$ ,  $f_{n1} = 0.242$ ,  $f_{02} = 1.96$ ,  $Q_2 = 0.7$ ,  $f_{n2} = 0.6$ ,  $f_{03} = 0.987$ ,  $f_{n3} = 0.753$ ,  $Q_3 = 10$ ). When compared with the topology of Figure 16, this approach uses lower and more restricted clock frequencies. The obtained notch in Mode 2 is shallower although the topology is more efficient.

### Output Noise

The wideband RMS noise of the LTC1061 outputs is nearly independent from the clock frequency. The LTC1061 noise when operating with  $\pm 2.5V$  supply is lower, as Table 3 indicates. The noise at the bandpass and lowpass outputs increases rough as the  $\sqrt{Q}$ . Also the noise increases when the clock-to-center frequency ratio is altered with external resistors to exceed the internally set 100:1 or 50:1 ratios. Under this condition, the noise increases square root-wise.

### Output Offsets

The equivalent input offsets of the LTC1061 are shown in Figure 23. The DC offset at the filter bandpass output is always equal to  $V_{OS3}$ . The DC offsets at the remaining two outputs (Notch and LP) depend on the mode of operation and external resistor ratios. Table 4 illustrates this.

It is important to know the value of the DC output offsets, especially when the filter handles input signals with large dynamic range. As a rule of thumb, the output DC offsets increase when:

1. The Qs decrease
2. The ratio ( $f_{CLK}/f_0$ ) increases beyond 100:1. This is done by decreasing either the (R2/R4) or the R6/(R5 + R6) resistor ratios.

# MODES OF OPERATION

Table 3. Wideband RMS Noise

$V_S (\pm V)$	$f_{CLK}/f_0$	NOTCH/HP ( $\mu V_{RMS}$ )	BP ( $\mu V_{RMS}$ )	LP ( $\mu V_{RMS}$ )	CONDITIONS
5.0	50:1	45	55	70	Mode 1, R1 = R2 = R3 Q = 1
5.0	100:1	65	65	85	
2.5	50:1	30	30	45	
2.5	100:1	40	40	60	
5.0	50:1	18	150	150	Mode 1, Q = 10 R1 = R3 for BP Out R1 = R2 for LP Out
5.0	100:1	20	200	200	
2.5	50:1	15	100	100	
2.5	100:1	17	140	140	
5.0	50:1	57	57	62	Mode 3, R1 = R2 = R3 = R4 Q = 1
5.0	100:1	72	72	80	
2.5	50:1	40	40	42	
2.5	100:1	50	50	53	
5.0	50:1	135	120	140	Mode 3, R2 = R4, Q = 10 R3 = R1 for BP Out R4 = R1 for LP and HP Out
5.0	100:1	170	160	185	
2.5	50:1	100	88	100	
2.5	100:1	125	115	130	

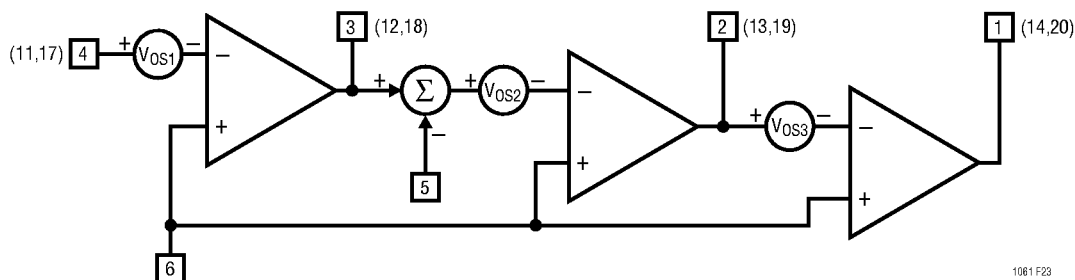

Figure 23. Equivalent Input Offsets of 1/3 LTC1061 Filter Building Block.

Table 4

MODE	$V_{OSN}$ PIN 3 (18)	$V_{OSBP}$ PIN 2 (19)	$V_{OSLP}$ PIN 1 (20)
1	$V_{OS1} [(1/Q) + 1 +    H_{OLP}   ] - V_{OS3}/Q$	$V_{OS3}$	$V_{OSN} - V_{OS2}$
1b	$V_{OS1} [(1/Q) + 1 + R2/R1] - V_{OS3}/Q$	$V_{OS3}$	$-(V_{OSN} - V_{OS2})(1 + R5/R6)$
2	$[V_{OS1} (1 + R2/R1 + R2/R3 + R2/R4) - V_{OS3}(R2/R3)] \times [R4/(R2 + R4)] + V_{OS2}[R2/(R2 + R4)]$	$V_{OS3}$	$V_{OSN} - V_{OS2}$
3	$V_{OS2}$	$V_{OS3}$	$V_{OS1} (1 + R4/R1 + R4/R2 + R4/R3) - V_{OS2}(R4/R2) - V_{OS3} (R4/R3)$

**PACKAGE DESCRIPTION** Dimensions in inches (millimeters) unless otherwise noted.

**J Package  
20-Lead Ceramic DIP**

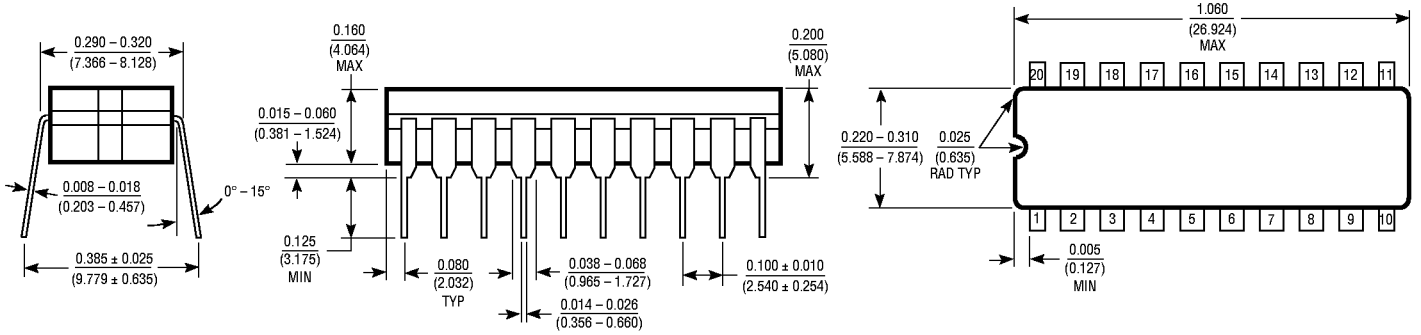

**N Package  
20-Lead Plastic DIP**

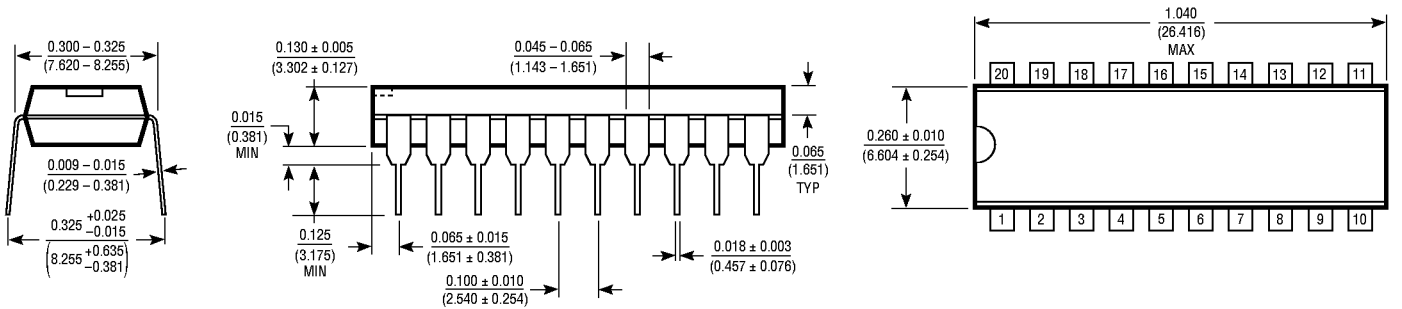

**S Package  
20-Lead Plastic SOL**

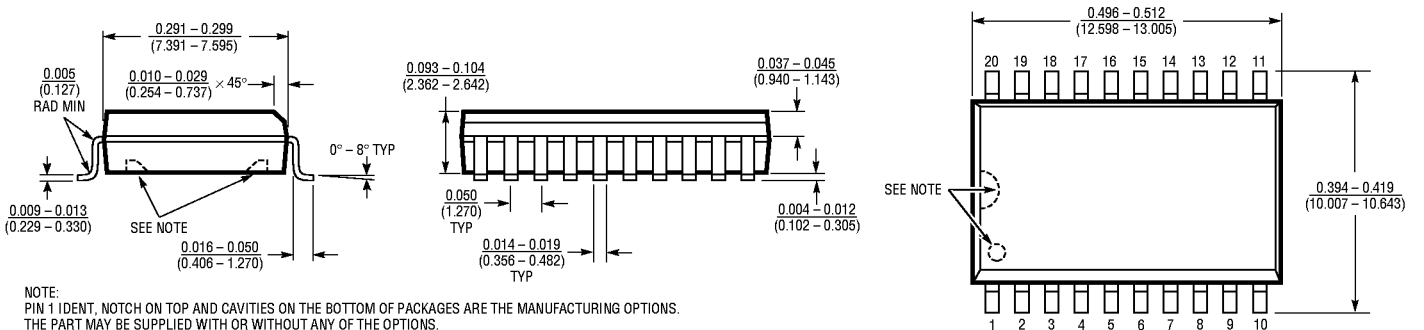

## U.S. Area Sales Offices

### NORTHEAST REGION

**Linear Technology Corporation**  
One Oxford Valley  
2300 E. Lincoln Hwy., Suite 306  
Langhorne, PA 19047  
Phone: (215) 757-8578  
FAX: (215) 757-5631

### Linear Technology Corporation

266 Lowell St., Suite B-8  
Wilmington, MA 01887  
Phone: (508) 658-3881  
FAX: (508) 658-2701

### SOUTHEAST REGION

**Linear Technology Corporation**  
17060 Dallas Parkway  
Suite 208  
Dallas, TX 75248  
Phone: (214) 733-3071  
FAX: (214) 380-5138

### CENTRAL REGION

**Linear Technology Corporation**  
Chesapeake Square  
229 Mitchell Court, Suite A-25  
Addison, IL 60101  
Phone: (708) 620-6910  
FAX: (708) 620-6977

### SOUTHWEST REGION

**Linear Technology Corporation**  
22141 Ventura Blvd.  
Suite 206  
Woodland Hills, CA 91364  
Phone: (818) 703-0835  
FAX: (818) 703-0517

### NORTHWEST REGION

**Linear Technology Corporation**  
782 Sycamore Dr.  
Milpitas, CA 95035  
Phone: (408) 428-2050  
FAX: (408) 432-6331

## International Sales Offices

### FRANCE

**Linear Technology S.A.R.L.**  
Immeuble "Le Quartz"  
58 Chemin de la Justice  
92290 Chatenay Malabry  
France  
Phone: 33-1-41079555  
FAX: 33-1-46314613

### GERMANY

**Linear Technolgy GMBH**  
Untere Hauptstr. 9  
D-85386 Eching  
Germany  
Phone: 49-89-3197410  
FAX: 49-89-3194821

### JAPAN

**Linear Technology KK**  
5F YZ Bldg.  
4-4-12 Iidabashi, Chiyoda-Ku  
Tokyo, 102 Japan  
Phone: 81-3-3237-7891  
FAX: 81-3-3237-8010

### KOREA

**Linear Technology Korea Branch**  
Namsong Building, #505  
Itaewon-Dong 260-199  
Yongsan-Ku, Seoul  
Korea  
Phone: 82-2-792-1617  
FAX: 82-2-792-1619

### SINGAPORE

**Linear Technology Pte. Ltd.**  
101 Boon Keng Road  
#02-15 Kallang Ind. Estates  
Singapore 1233  
Phone: 65-293-5322  
FAX: 65-292-0398

### TAIWAN

**Linear Technology Corporation**  
Rm. 801, No. 46, Sec. 2  
Chung Shan N. Rd.  
Taipei, Taiwan, R.O.C.  
Phone: 886-2-521-7575  
FAX: 886-2-562-2285

### UNITED KINGDOM

**Linear Technology (UK) Ltd.**  
The Coliseum, Riverside Way  
Camberley, Surrey GU15 3YL  
United Kingdom  
Phone: 44-276-677676  
FAX: 44-276-64851

## World Headquarters

**Linear Technology Corporation**  
1630 McCarthy Blvd.  
Milpitas, CA 95035-7487  
Phone: (408) 432-1900  
FAX: (408) 434-0507