



Modulelink(Shenzhen) Technology Co., Ltd.

[Http://www.modulelink.net](http://www.modulelink.net)

Optical network solutions provider

X2 10G Transceiver M10GB-X2-CWDM-80D

FEATURES

- XAUI Electrical Interface: 4 Lanes @ 3.125Gbit/s
- Hot Z-Pluggable
- SC-Duplex Optical Receptacle
- MDIO, DOM Support
- Cooled CWDM EML
- APD Photo-detector
- Operating Case Temperature: 0 to 70 °C
- Compliant to IEEE 802.3ae 10GBASE-ZR Application
- Compliant to X2 MSA

REFERENCE

IEEE 802.3ae as 10GBASE-ZR, X2 MSA Release1.0B

DESCRIPTION

General

Modulelink's 10Gb/s X2 transceiver module M10GB-X2-CWDM-80D is a hot pluggable in the Z-direction module that is usable in typical router line card applications, Storage, IP network and LAN and compliant to X2 MSA. The M10GB-X2-CWDM-80D is a fully integrated 10.3Gbit/s optical transceiver module that consists of a 10.3Gbit/s optical transmitter and receiver, XAUI interface, Mux and Demux with clock and data recovery(CDR). This version of Modulelink Inc. transceiver line uses an cooled CWDM EML Laser Diode to achieve 80km over standard single mode fiber as 10GBASE-ZR of the IEEE 802.3ae.

Add: 3rd floor Block 2, Tianlong Science Industry Park, Kengzhi Town, Longgang Area, Shenzhen, China.

Tel: 86-755-86101649

Fax: 86-755-86101640

Dec 10 / 2011

E-mail:sales@modulelink.net

Website: www.modulelink.net

Rev.1.3



Modulelink(Shenzhen) Technology Co., Ltd.

Http://www.modulelink.net

Optical network solutions provider

PRODUCT SELECTION

M10GB-X2-CWDM-80D

| Wavelength | xx | Wavelength | xx |
|------------|----|------------|----|
| 1470 nm | 47 | 1550 nm | 55 |
| 1490 nm | 49 | 1570 nm | 57 |
| 1510 nm | 51 | 1590 nm | 59 |
| 1530 nm | 53 | 1610 nm | 61 |

PERFORMANCE SPECIFICATIONS

Optical Characteristics

Table 1. Optical Characteristics

| No. | Parameters | Symbols | Min. | Typ. | Max. | Unit | Remarks |
|-----|--|-----------|---------|---------|---------|--------|---------|
| 1 | Optical Wavelength | λ | (X-6.5) | (X+1) | (X+6.5) | nm | |
| 2 | Signaling speed | | - | 10.3125 | - | Gbit/s | |
| 3 | Signaling speed variation from nominal | | -100 | - | +100 | ppm | |
| 5 | Optical Output Power | Pf | 0 | - | +5 | dBm | Average |
| 6 | Side Mode Suppression Ratio | Sr | 30 | - | - | dB | Average |
| 7 | Extinction Ratio | Er | 9.0 | - | - | dB | |
| 8 | Off Transmit Power | Poff | - | - | -30 | dBm | Average |
| 9 | Tx Jitter Generation(peak-to-peak) | Txj1 | - | - | 0.1 | UI | |
| 10 | Tx Jitter Generation(RMS) | Txj2 | - | - | 0.01 | UI | |
| 11 | Receiver Sensitivity | Rsense | - | - | -24 | dBm | |
| 12 | Receiver Overload | Rro | +0.5 | - | - | dBm | Average |
| 13 | Receiver Return Loss | RL | 12 | - | - | dB | Average |

Add: 3rd floor Block 2, Tianlong Science Industry Park, Kengzhi Town, Longgang Area, Shenzhen, China.

Tel: 86-755-86101649

Fax: 86-755-86101640

Dec 10 / 2011

E-mail:sales@modulelink.net

Website: www.modulelink.net

Rev.1.3



Modulelink(Shenzhen) Technology Co., Ltd.

Http://www.modulelink.net

Optical network solutions provider

Electrical Performance

Table2. Power Supply Characteristics

| No. | Parameter | Symbol | Min. | Typ. | Max. | Unit | Remarks |
|-----|--------------------------------------|--------|-------|-------|-------|------|----------|
| 1 | Supply Voltage | VCC1 | 3.135 | 3.300 | 3.465 | V | |
| 2 | Supply Voltage | VCC2 | 1.152 | 1.200 | 1.248 | V | |
| 3 | Supply Current | ICC1 | - | - | 1.4 | A | +3.3 V |
| 4 | Supply Current | ICC2 | - | - | 1.7 | A | APS |
| 5 | Power Consumption | PDS | - | - | 4.0 | W | |
| 6 | Power supply stabilization time | TDF | - | - | 500 | ms | Figure 7 |
| 7 | Initialization Time | TINIT | - | - | 5 | s | Figure 7 |
| 8 | RESET Assert Time | TRESET | 1 | - | - | ms | Figure 9 |
| 9 | Hold Time after rising edge of RESET | THOLD | 500 | - | - | ms | Figure 9 |

Table 3. XAUI Driver Characteristics

| No. | Parameter | Symbol | Min. | Typ. | Max. | Unit | Remarks |
|-----|------------------------|--------|------|-------|------|--------|--------------------------|
| 1 | Baud Rate | | - | 3.125 | - | Gbit/s | |
| 2 | Baud Rate Tolerance | | -100 | - | +100 | ppm | |
| 3 | Differential Amplitude | | 800 | - | 1600 | mVPP | AC, near-end value |

Table4. 1.2V CMOS Interface Characteristics

| No. | Parameter | Symbol | Min. | Typ. | Max. | Unit | Remarks |
|-----|-------------------------|--------|------|------|------|-------|----------------------------|
| 1 | Input High Voltage | VIH | 0.84 | - | 1.5 | V | |
| 2 | Input Low Voltage | VIL | -0.3 | - | 0.36 | V | |
| 3 | Input Pull-down Current | IIn | 20 | 40 | 120 | μA | Vih=1.2V |
| 4 | Output High Voltage | VOH | 1.0 | - | - | V | Pull-up=10k ohm to 1.2V |
| 5 | Output Low Voltage | VOL | - | - | 0.2 | V | |
| 6 | Pull up Resistance | RLAS1 | 10 | - | 22 | k ohm | |

Add: 3rd floor Block 2, Tianlong Science Industry Park, Kengzhi Town, Longgang Area, Shenzhen, China.

Tel: 86-755-86101649

Fax: 86-755-86101640

Dec 10 / 2011

E-mail:sales@modulelink.net

Website: www.modulelink.net

Rev.1.3



Modulelink(Shenzhen) Technology Co., Ltd.

Http://www.modulelink.net

Optical network solutions provider

| | | | | | | | |
|---|------------------|-------|---|---|-----|----|--|
| 7 | Capacitance | CLASI | - | - | 10 | pF | |
| 8 | Load Capacitance | CLoad | - | - | 320 | pF | |

Table5. MDIO Bidirectional Interface Characteristics

| No. | Parameter | Symbol | Min. | Typ. | Max. | Unit | Remarks |
|-----|--|---------|------|------|------|------|---------|
| 1 | Input High Voltage | VIHM | 0.84 | - | 1.5 | V | |
| 2 | Input Low Voltage | VILM | -0.3 | - | 0.36 | V | |
| 3 | Output High Voltage | VOHM | 1.0 | - | 1.5 | V | |
| 4 | Output Low Voltage | VOLM | -0.3 | - | 0.2 | V | |
| 5 | Pull up Resistance | RMDIO | 200 | - | | Ohm | |
| 6 | MDC min high/low time | THM,TLM | 160 | - | - | ns | |
| 7 | MDC Frequency | 1/TCK | TBD | - | 2.5 | MHz | |
| 8 | Setup time | TDIS | 10 | - | - | ns | |
| 9 | Hold time | TDIH | 10 | - | - | ns | |
| 10 | MDIO output delay after rising edge of MDC | TPD | 0 | - | 300 | ns | |
| 12 | Input Capacitance | Ci | - | - | 10 | pF | |
| 13 | Bus Loading | CL | - | - | 470 | pF | |

Note: The maximum value of RMDIO depends on bus loading(CL) , input capacitance(Ci), and MDC frequency(1/TCK).

Table6. X2 Pin Configuration

| Pin # | Symbol | I/O | Logic | Description |
|-------|----------|-----|--------|-----------------------|
| 1 | GND | I | Supply | Electrical ground |
| 2 | GND | I | Supply | Electrical ground |
| 3 | GND | I | Supply | Electrical ground |
| 4 | RESERVED | - | - | Reserved |
| 5 | 3.3 V | I | Supply | Power |
| 6 | 3.3 V | I | Supply | Power |
| 7 | APS | I | Supply | Adaptive Power Supply |

Add: 3rd floor Block 2, Tianlong Science Industry Park, Kengzhi Town, Longgang Area, Shenzhen, China.

Tel: 86-755-86101649

Fax: 86-755-86101640

Dec 10 / 2011

E-mail:sales@modulelink.net

Website: www.modulelink.net

Rev.1.3



Modulelink(Shenzhen) Technology Co., Ltd.

[Http://www.modulelink.net](http://www.modulelink.net)

Optical network solutions provider

| | | | | |
|----|---------------|-----|------------|--|
| 8 | APS | I | Supply | Adaptive Power Supply |
| 9 | LASI | O | Open Drain | Link Alarm Status Interrupt. 10-22k ohm pull up on host. |
| 10 | RESET | I | 1.2V CMOS | TX OFF when MDIO RESET |
| 11 | VEND SPECIFIC | - | - | Vendor Specific Pin. Leave unconnected. |
| 12 | TX ON/OFF | I | 1.2V CMOS | Transmitter ON/OFF |
| 13 | RESERVED | - | - | Reserved |
| 14 | MOD DETECT | O | - | Pulled low inside module through 1k ohm. |
| 15 | VEND SPECIFIC | - | - | Vendor Specific Pin. Leave unconnected. |
| 16 | VEND SPECIFIC | - | - | Vendor Specific Pin. Leave unconnected. |
| 17 | MDIO | I/O | Open Drain | Management Data IO |
| 18 | MDC | I | 1.2V CMOS | Management Data Clock |
| 19 | PRTAD4 | I | 1.2V CMOS | Port Address bit 4 (Low=0) |
| 20 | PRTAD3 | I | 1.2V CMOS | Port Address bit 3 (Low=0) |
| 21 | PRTAD2 | I | 1.2V CMOS | Port Address bit 2 (Low=0) |
| 22 | PRTAD1 | I | 1.2V CMOS | Port Address bit 1 (Low=0) |
| 23 | PRTAD0 | I | 1.2V CMOS | Port Address bit 0 (Low=0) |
| 24 | VEND SPECIFIC | - | - | Vendor Specific Pin. Leave unconnected. |
| 25 | APS SET | O | - | Feedback output for APS |
| 26 | RESERVED | - | - | Reserved for Avalanche Photodiode use. |

Add: 3rd floor Block 2, Tianlong Science Industry Park, Kengzhi Town, Longgang Area, Shenzhen, China.

Tel: 86-755-86101649

Fax: 86-755-86101640

Dec 10 / 2011

E-mail:sales@modulelink.net

Website: www.modulelink.net

Rev.1.3



Modulelink(Shenzhen) Technology Co., Ltd.

[Http://www.modulelink.net](http://www.modulelink.net)

Optical network solutions provider

| | | | | |
|----|------------|---|--------|----------------------------|
| 27 | APS SENSE | O | Analog | APS Sense Connection |
| 28 | APS | I | Supply | Adaptive Power Supply |
| 29 | APS | I | Supply | Adaptive Power Supply |
| 30 | 3.3 V | I | Supply | Power |
| 31 | 3.3 V | I | Supply | Power |
| 32 | RESERVED | - | - | Reserved |
| 33 | GND | I | Supply | Electrical Ground |
| 34 | GND | I | Supply | Electrical Ground |
| 35 | GND | I | Supply | Electrical Ground |
| 36 | GND | I | Supply | Electrical Ground |
| 37 | GND | I | Supply | Electrical Ground |
| 38 | RESERVED | - | - | Reserved |
| 39 | RESERVED | - | - | Reserved |
| 40 | GND | I | Supply | Electrical Ground |
| 41 | RX LANE 0+ | O | AC | Module XAUI Output Lane 0+ |
| 42 | RX LANE 0- | O | AC | Module XAUI Output Lane 0- |
| 43 | GND | I | Supply | Electrical Ground |
| 44 | RX LANE 1+ | O | AC | Module XAUI Output Lane 1+ |

Add: 3rd floor Block 2, Tianlong Science Industry Park, Kengzhi Town, Longgang Area, Shenzhen, China.

Tel: 86-755-86101649

Fax: 86-755-86101640

Dec 10 / 2011

E-mail:sales@modulelink.net

Website: www.modulelink.net

Rev.1.3



Modulelink(Shenzhen) Technology Co., Ltd.

[Http://www.modulelink.net](http://www.modulelink.net)

Optical network solutions provider

| | | | | |
|----|------------|---|--------|----------------------------|
| 45 | RX LANE 1- | O | AC | Module XAUI Output Lane 1- |
| 46 | GND | I | Supply | Electrical Ground |
| 47 | RX LANE 2+ | O | AC | Module XAUI Output Lane 2+ |
| 48 | RX LANE 2- | O | AC | Module XAUI Output Lane 2- |
| 49 | GND | I | Supply | Electrical Ground |
| 50 | RX LANE 3+ | O | AC | Module XAUI Output Lane 3+ |
| 51 | RX LANE 3- | O | AC | Module XAUI Output Lane 3- |
| 52 | GND | I | Supply | Electrical Ground |
| 53 | GND | I | Supply | Electrical Ground |
| 54 | GND | I | Supply | Electrical Ground |
| 55 | TX LANE 0+ | I | AC | Module XAUI Input Lane 0+ |
| 56 | TX LANE 0- | I | AC | Module XAUI Input Lane 0- |
| 57 | GND | I | Supply | Electrical Ground |
| 58 | TX LANE 1+ | I | AC | Module XAUI Input Lane 1+ |
| 59 | TX LANE 1- | I | AC | Module XAUI Input Lane 1- |
| 60 | GND | I | Supply | Electrical Ground |
| 61 | TX LANE 2+ | I | AC | Module XAUI Input Lane 2+ |
| 62 | TX LANE 2- | I | AC | Module XAUI Input Lane 2- |

Add: 3rd floor Block 2, Tianlong Science Industry Park, Kengzhi Town, Longgang Area, Shenzhen, China.

Tel: 86-755-86101649

Fax: 86-755-86101640

Dec 10 / 2011

E-mail:sales@modulelink.net

Website: www.modulelink.net

Rev.1.3



Modulelink(Shenzhen) Technology Co., Ltd.

[Http://www.modulelink.net](http://www.modulelink.net)

Optical network solutions provider

| | | | | |
|----|------------|---|--------|---------------------------|
| 63 | GND | I | Supply | Electrical Ground |
| 64 | TX LANE 3+ | I | AC | Module XAUI Input Lane 3+ |
| 65 | TX LANE 3- | I | AC | Module XAUI Input Lane 3- |
| 66 | GND | I | Supply | Electrical Ground |
| 67 | RESERVED | - | - | Reserved |
| 68 | RESERVED | - | - | Reserved |
| 69 | GND | I | Supply | Electrical Ground |
| 70 | GND | I | Supply | Electrical Ground |

Note: Case is connected to electrical ground in the module.

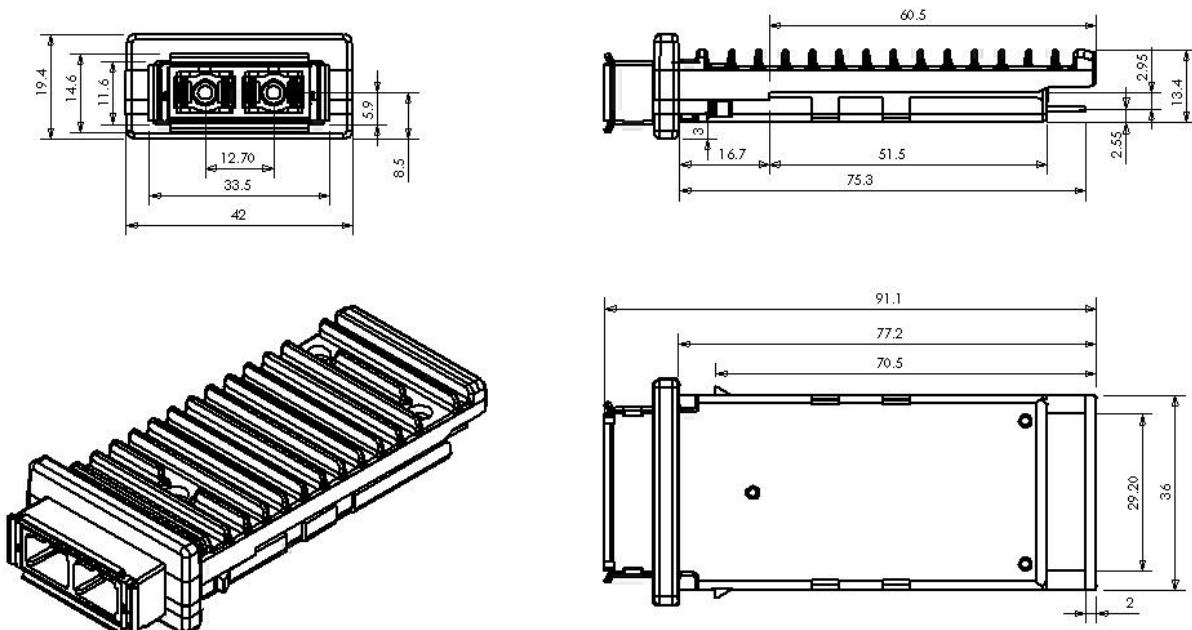

Add: 3rd floor Block 2, Tianlong Science Industry Park, Kengzhi Town, Longgang Area, Shenzhen, China.
 Tel: 86-755-86101649 Fax: 86-755-86101640 Dec 10 / 2011
 E-mail:sales@modulelink.net Website: www.modulelink.net Rev.1.3

Figure 1 Mechanical dimensions

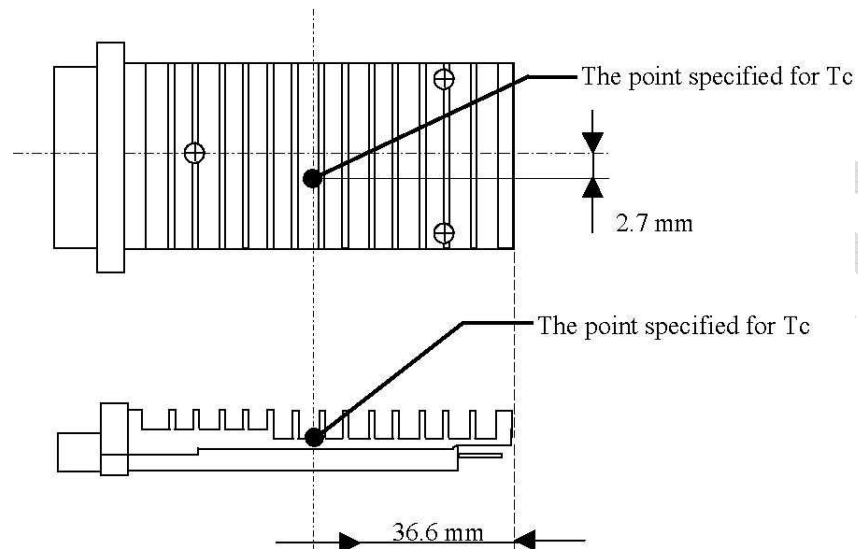

Figure 2 The Point Specified for Case Temperature (Tc)

Register Definition

| Device Address (Dec) Register Address (Hex) | PMA/PMD 1 | PCS 3 | PHY XS 4 |
|---|----------------------------|------------------------|---------------------------|
| 0x0000 | PMA/PMD Control1 | PCS Control1 | PHY XS Control1 |
| 0x0001 | PMA/PMD Status1 | PCS Status1 | PHY XS Status1 |
| 0x0002 | PMA/PMD Device Identifier0 | PCS Device Identifier0 | PHY XS Device Identifier0 |
| 0x0003 | PMA/PMD Device Identifier1 | PCS Device Identifier1 | PHY XS Device Identifier1 |
| 0x0004 | PMA/PMD Speed Ability | PCS Speed Ability | PHY XS Speed Ability |
| 0x0005 | PMA/PMD Device in Package1 | PCS Device in Package1 | PHY XS Device in Package1 |
| 0x0006 | PMA/PMD Device in Package2 | PCS Device in Package2 | PHY XS Device in Package2 |
| 0x0007 | 10G PMA/PMD Control2 | PCS Control2 | Reserved |



Modulelink(Shenzhen) Technology Co., Ltd.

[Http://www.modulelink.net](http://www.modulelink.net)

Optical network solutions provider

| | | | |
|-----------------|----------------------------------|--|---------------------------|
| 0x0008 | 10G PMA/PMD Status2 | PCS Status2 | PHY XS Status2 |
| 0x0009 | 10G PMD Transmit Disable | Reserved | Reserved |
| 0x000A | 10G PMD Receive Signal O.K. | Reserved | Reserved |
| 0x000E | Package Identifier0 | Reserved | Reserved |
| 0x000F | Package Identifier1 | Reserved | Reserved |
| 0x0018 | Reserved | Reserved | 10G PHY XGXS Lane Status |
| 0x0019 | Reserved | Reserved | 10G PHY XGXS Test Control |
| 0x0020 | Reserved | 10GBASE-R PCS Status1 | Reserved |
| 0x0021 | Reserved | 10GBASE-R PCS Status2 | Reserved |
| 0x0022 | Reserved | 10GBASE-R PCS Test pattern Seed A0 | Reserved |
| 0x0023 | Reserved | 10GBASE-R PCS Test pattern Seed A1 | Reserved |
| 0x0024 | Reserved | 10GBASE-R PCS Test pattern Seed A2 | Reserved |
| 0x0025 | Reserved | 10GBASE-R PCS Test pattern Seed A3 | Reserved |
| 0x0026 | Reserved | 10GBASE-R PCS Test pattern Seed B0 | Reserved |
| 0x0027 | Reserved | 10GBASE-R PCS Test pattern Seed B1 | Reserved |
| 0x0028 | Reserved | 10GBASE-R PCS Test pattern Seed B2 | Reserved |
| 0x0029 | Reserved | 10GBASE-R PCS Test pattern Seed B3 | Reserved |
| 0x002A | Reserved | 10GBASE-R PCS Test pattern Control | Reserved |
| 0x002B | Reserved | 10GBASE-R PCS Test pattern Error counter | Reserved |
| 0x8000 | NVR Control/Status (X2 Register) | Reserved | |
| 0x8007 - 0x807D | NVR (X2 Register) | Reserved | |
| 0x807E- 0x80AD | Customer AREA | Reserved | |

Add: 3rd floor Block 2, Tianlong Science Industry Park, Kengzhi Town, Longgang Area, Shenzhen, China.

Tel: 86-755-86101649

Fax: 86-755-86101640

Dec 10 / 2011

E-mail:sales@modulelink.net

Website: www.modulelink.net

Rev.1.3



Modulelink(Shenzhen) Technology Co., Ltd.

[Http://www.modulelink.net](http://www.modulelink.net)

Optical network solutions provider

| | | |
|-----------------|---|----------|
| 0x80AE - 0x8106 | MODULELINK Specific Area(X2 Register) | Reserved |
| 0x9000 | RX_ALARM Control (X2 Register) | Reserved |
| 0x9001 | TX_ALARM Control (X2 Register) | Reserved |
| 0x9002 | LASI Control (X2 Register) | Reserved |
| 0x9003 | RX_ALARM Status (X2 Register) | Reserved |
| 0x9004 | TX_ALARM Status (X2 Register) | Reserved |
| 0x9005 | LASI Status (X2 Register) | Reserved |
| 0x9006 | TX_FLAG Control Bits | Reserved |
| 0x9007 | RX_FLAG Control Bits | Reserved |
| 0xA000 - 0xA027 | Alarm and Warning Thresholds | Reserved |
| 0xA060 - 0xA069 | Digital Optical Monitoring Interface | Reserved |
| 0xA06F | DOM Capability - Extended | Reserved |
| 0xA070 | TX_ALARM_FLAG Bits | Reserved |
| 0xA071 | RX_ALARM_FLAG Bits | Reserved |
| 0xA074 | TX_WARNING_FLAG Bits | Reserved |
| 0xA075 | RX_WARNING_FLAG Bits | Reserved |
| 0xA100 | Optional Digital Optical Monitoring (DOM) Control/Status | Reserved |



Add: 3rd floor Block 2, Tianlong Science Industry Park, Kengzhi Town, Longgang Area, Shenzhen, China.

Tel: 86-755-86101649

Fax: 86-755-86101640

Dec 10 / 2011

E-mail:sales@modulelink.net

Website: www.modulelink.net

Rev.1.3