

SCM1501B Contactor Power Saving Controller

Features

- The input voltage is detected in real time, and the contactor operating voltage can be accurately set
- It can work in a wide input voltage range of 2.5:1
- The pick-up current and the holding current can be set separately, and the contactor coil design is simpler
- With built-in analog frequency jitter, it is easy to solve EMI problems
- The chip's power supply range is 16.5V~500V, which meets most of the contactor input voltage requirements
- With fast shutdown function, it reduces the contactor shutdown delay
- AC input busbar does not require large capacitance

Package

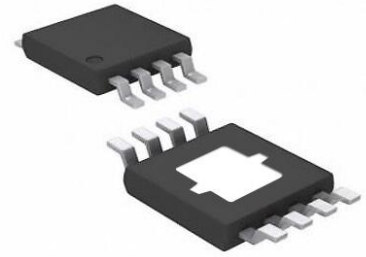

Product package: ESOP-8.

Please see "Ordering Information" for details

Applications

- Various contactor power saving transformation
- Wide voltage AC/DC universal contactor control

Functional

The SCM1501B is a contactor power-saving controller that reduces the pick-up and holding power consumption of the contactor.

The SCM1501B has a built-in high-voltage startup circuit that can quickly start the controller with a charging current of 4mA (typ.) within the input voltage range of 16.5V~500V, so as to respond quickly when the contactor is operated. If the auxiliary power supply is not used, SCM1501B will take power directly from the input to realize self-power supply. In addition, the SCM1501B can also control the contactor coil to achieve high current pick-up and low current holding. During the low current holding stage, when the input undervoltage occurs or the controller is disabled, the controller activates the fast shutdown function to quickly disconnect the contactor to reduce the influence of the SCM1501B on the disconnecting performance of the contactor.

Typical Application Circuit

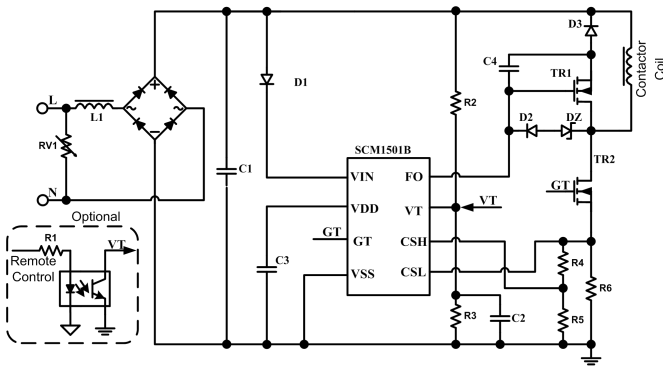

Functional Curve

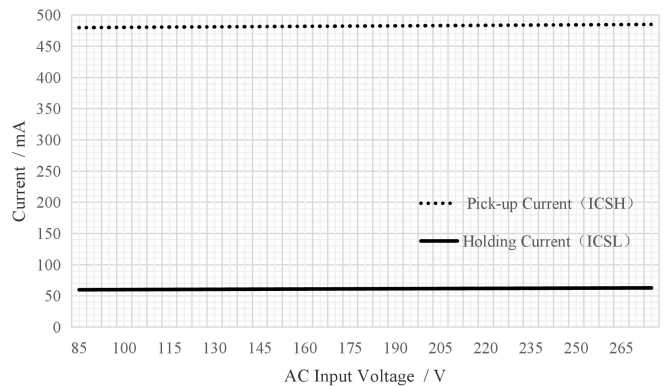

Catalog

Features and Package.....	1	Typical Curve.....	4
Application.....	1	Functional Application.....	5
Functional Description.....	1	Extended Output Design.....	5
Typical Application Circuit and Functional Curve.....	1	Application Circuit.....	6
Pins and Pins Description.....	1	Product model overview.....	6
Absolute Maximum Ratings.....	3	Recommendations.....	7
Recommended Operating Conditions.....	3	Ordering Information.....	8
Electrical Characteristics.....	3		

Pins

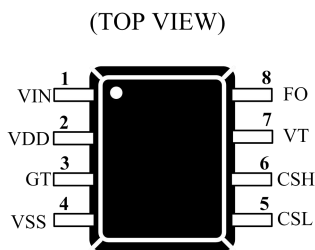

Internal Block Diagram

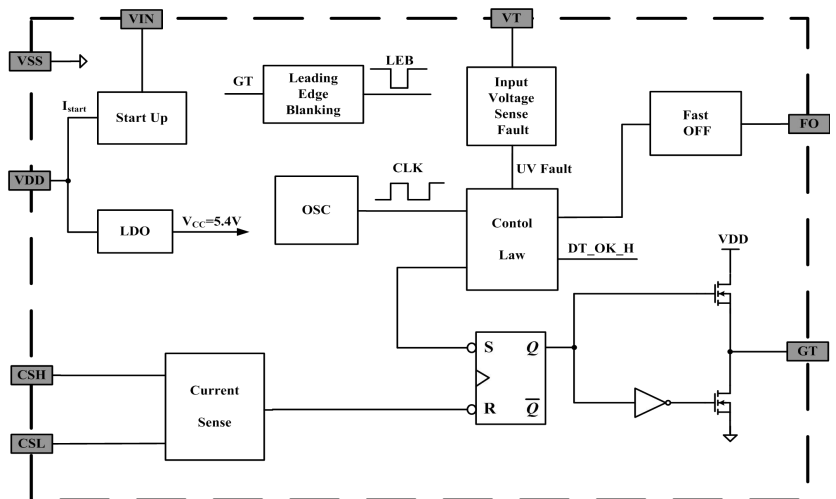

Pin Descriptions

NUMBER	NAME	I/O	DESCRIPTION
1	VIN	P	High voltage starting circuit input
2	VDD	P	Chip supply pin
3	GT	O	Power MOSFET drive
4	VSS	P	Chip ground
5	CSL	I	Holding state current sampling pin
6	CSH	I	Pickup state current sampling pin
7	VT	I	Input voltage detection
8	FO	O	Bootstrap drive for fast turn-off transistor

Pin Function Descriptions

VIN (high voltage input): The high voltage power input port of the controller can be connected to the DC input voltage below 500V. The DC input voltage is stepped down to the VDD pin via the LDO circuit inside the VIN pin. If there is no auxiliary power supply, the VDD pin voltage will eventually stabilize at 17V.

VDD (power supply terminal): power supply port of the controller, external bypass capacitor C_{VDD} . After power-on, the built-in LDO circuit charges the capacitor C_{VDD} and the VDD voltage rises. When the VDD voltage is charged to the startup threshold V_{VDD_ON} the controller begins to output the drive signal, while the startup circuit still charges the capacitor until $V_{VDD}=V_{VDD_HD}$. If there is no auxiliary power supply, the LDO circuit will continue to operate to maintain $V_{VDD}=V_{VDD_HD}$.

GT (drive output): Outputs a square wave signal with an average frequency of 23.5 kHz. During the pickup stage, the contactor inductance is small, so there is a case where the duty ratio is as long as 100%. In this stage, the duty ratio is without any regularity, After entering the holding stage, the inductance of the contactor becomes larger and the duty ratio becomes regular. At this time, the square wave frequency can be seen to have periodic jitter, the frequency is jittered within the range of $\pm 6.5\%$.

VSS (ground): Signal reference ground.

CSH (pick-up current detection): The high current detection pin only controls the duty cycle of the square wave signal output by the GT pin during the pickup stage. That is, when the CSH pin voltage is greater than 1.2V, the GT pin outputs low power level.

CSL (holding current detection): A small current detection pin that controls the duty cycle of the square wave signal output from the GT pin only during the holding stage. That is, when the CSL pin voltage is greater than 0.3V, the GT pin outputs low power level.

VT (input voltage detection): The external voltage divider sampling input voltage. In AC applications, the contactor operates at 2.4V and the shutdown voltage is 1.6V. The shutdown delay set by the controller is 0.66ms, which means that the input undervoltage protection will be entered when the VT pin voltage is less than 1.6V and lasts for 0.66ms.

FO (quick turn-off tube drive output): In normal operation mode, as long as the GT pin outputs a high level, $V_{FO}=V_{VDD}-0.6-V_{CSL}$. In order to charge the FO pin to the maximum value, it is necessary to charge the $V_{VDD}=V_{VDD_HD}$ to $V_{VDD}-0.6$ when the V_{CSL} is not very large after the first rising edge of the GT pin signal appears, so as to minimize the on-resistance of the fast switch-off transistor. During the holding stage, if the controller enters the input undervoltage protection, the FO will draw 1.2mA, so that the fast turn-off transistor TR1 operates in the sub-threshold region, and the demagnetization current slope of the inductor becomes larger, thereby reducing the delay of contactor contact pop-up. See "Fast shut-off" section for details.

Absolute Maximum Ratings

Test conditions: Free-air, normal operating temperature range (unless otherwise specified), voltage reference is ground.

PARAMETER	SYMBOL	MIN	MAX	UNIT
V_{VIN}	HV starting voltage	16.5	500	V
V_{VDD}	Bias supply voltage		20	
V_{GT}	GT pin voltage	-0.6	20	
V_{VT}, V_{CSL}, V_{CSH}	Voltage range	-0.6	6	
T_J	Working junction temperature range	-40	150	°C
T_{STG}	Storage temperature	-40	150	
	Soldering Temperature (Allowable reflow soldering temperature of chip within 10 seconds)		260	
Electrostatic discharge (ESD) rating	Human body model (HBM, except I/O to I/O)		2000	V
	Human body model (HBM, I/O to I/O)		1000	

Note: Permanent damage to the device may occur if the stress values listed in the "Maximum Ratings" table are exceeded. The reliability of the device may be affected by long-term operation under extreme rating conditions. All voltage values are based on the Earth (GND) reference. Current is the positive input and negative output of the specified terminal.

Recommended Operating Conditions

Test conditions: Free-air, normal operating temperature range (unless otherwise specified), $V_{DD}=12V, GATE=no\ load$.

SYMBOL	PARAMETER	MIN	MAX	UNIT
V_{VDD}	Bias supply operating voltage	9	18	V
C_3	VDD bypass capacitor	1	10	uF
C_4	Gate capacitance of quick turn-off tube TR1	0.047	0.47	uF

Electrical Characteristics

Unless otherwise stated, the following parameters were tested under normal temperature and pressure and in an unsealed environment.

SYMBOL	PARAMETER	TEST CONDITIONS	MIN	TYP	MAX	UNIT
I_{START}	Starting current	$V_{VIN}=60V$ current flowing from the VDD pin		4		mA
V_{VIN_BV}	VIN pin breakdown voltage	$I_{VIN}=10\mu A$	560			V
V_{VDD_ON}	Drive signal output point VDD pin voltage	$V_{VT}=3V$	9.95	11.05	12.16	V
V_{VDD_OFF}	Drive signal turn-off point VDD pin voltage	$V_{VT}=3V$	9.45	10.5	11.55	V
V_{VDD_HD}	VDD self-power supply sustaining voltage	$V_{VIN}=60V$	15.2	17	19.2	V
I_{START_OFF}	Self-powered off, VIN bias current	$V_{VIN}=400V$			10	uA
I_{VDD_STATE}	VDD pin chip static operating current	$V_{VDD}=18V, V_{VT}=0V$	125	250	375	uA
V_{ACT_AC}	VT pin contactor operating voltage	$V_{VDD}=18V$	2.26	2.4	2.54	V
V_{OFF_AC}	VT pin contactor turn-off voltage	$V_{VDD}=18V$	1.5	1.6	1.7	V
T_{D_CHANGE}	Mode switching delay for pick-up and holding	$V_{VDD}=18V$	80.36	98	115.64	mS
F_{BUCK}	Post-stage average switching frequency	$V_{VDD}=18V$, normal operation	21.15	23.5	25.85	kHz
F_{SK}	Frequency jitter	Peak-to-peak jitter compared to the average frequency, $T = 27^\circ C$		± 6.5		%
V_{CSHT}	CSH pin pick-up current comparison threshold	$V_{VDD}=18V$, pick-up stage	1.13	1.2	1.27	V
V_{CSLT}	CSL pin holding current comparison threshold	$V_{VDD}=18V$, holding stage	0.28	0.3	0.32	V
T_{ON_MIN}	Minimum on time	$V_{VDD}=18V, V_{CSL}=1.0V$	260	520	780	nS
T_{D_STOP}	Shutdown detection delay	$V_{VDD}=18V, V_{CSL}=1.0V$	0.32		1.50	mS

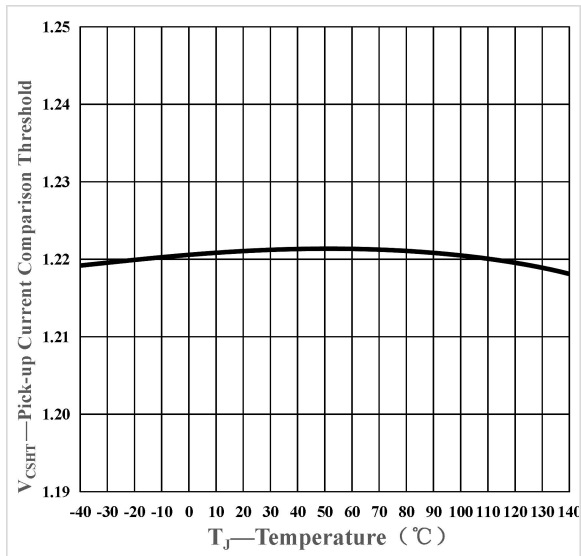

Fig. 1 CSH pin pick-up current comparison threshold (V_{CSHT}) VS Temperature

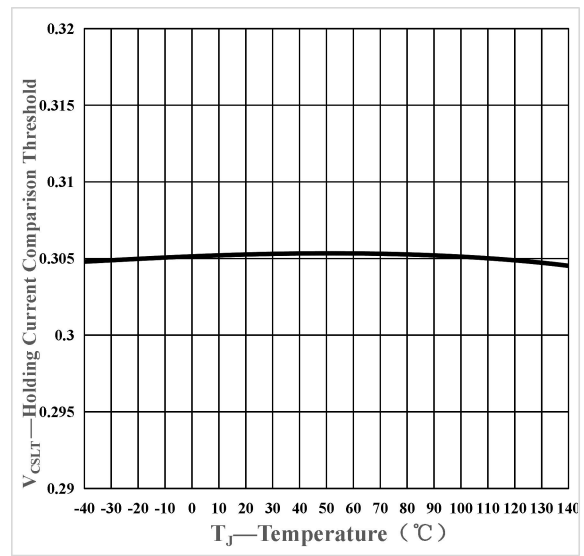

Fig. 2 CSL pin holding current comparison threshold (V_{CSLT}) VS Temperature

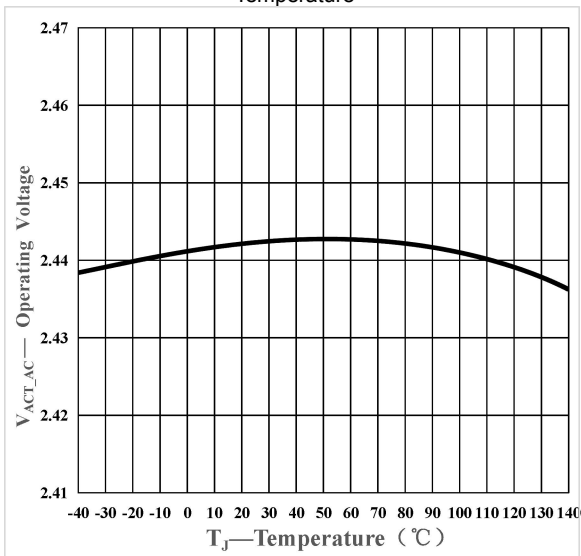

Fig. 3 VT pin contactor operating voltage (V_{ACT_AC}) VS Temperature

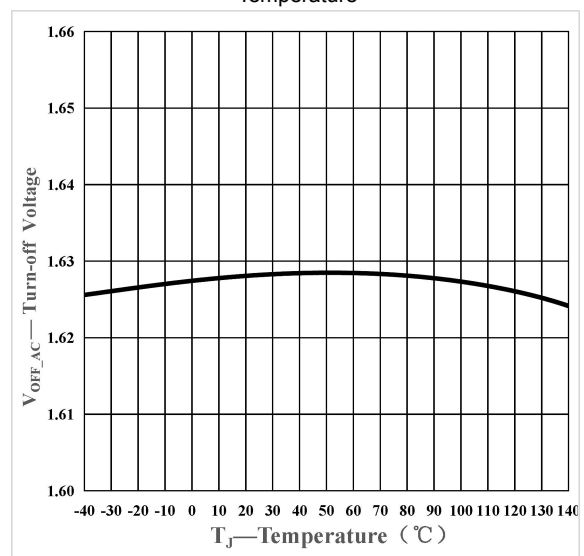

Fig. 4 VT pin contactor turn-off voltage (V_{OFF_AC}) VS Temperature

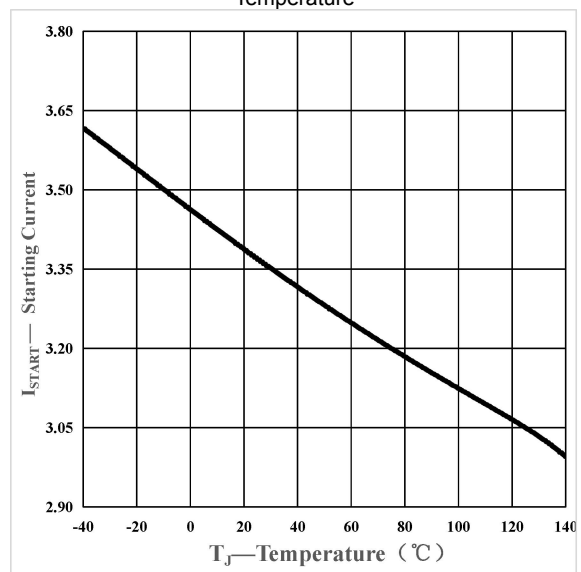

Fig. 5 Starting current (I_{START}) VS Temperature

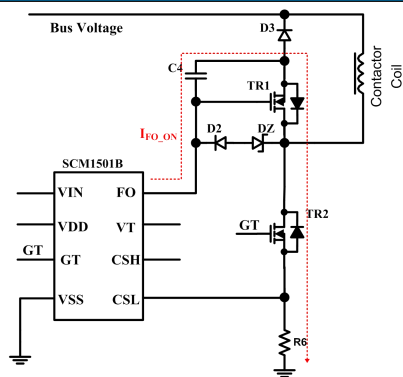

Fig. 6 Start-up circuit schematic

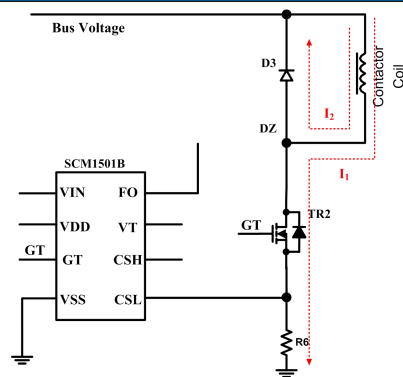

Fig. 7 Equivalent Circuits in the Pick-up and Holding Stages

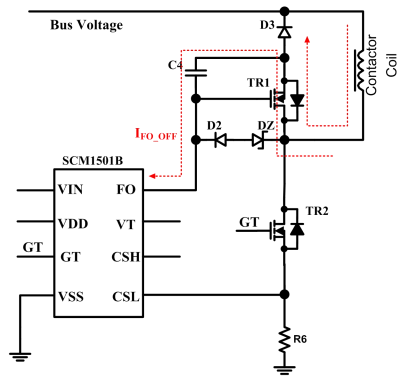

Fig. 8 Circuit schematic diagram of turn-off stage

(1) Figure 6, the working principle of the chip startup, see the working principle diagram of the startup process. After the chip is started, the GT will output a high level, and the FO will continue to output a current-driven MOS transistor TR1. FO charges the gate of MOS transistor TR1, and the current I_{FO_ON} path is as follows: When MOS transistor TR2 is turned on, the FO pin charges capacitor C4 through the body diode of MOS transistor TR1 and MOS transistor TR2. Each time the MOS transistor TR2 is turned on, the FO pin will charge the capacitor C4. Therefore, in the Pick-up and Holding stages, the MOS transistor TR1 is turned on all time.

(2) In Fig. 7, since the MOS transistor TR1 is turned on all time during normal operation, the main power circuit can be equivalent to the equivalent circuit of the Pick-up and Holding stages. When the MOS transistor TR2 is turned on, the contactor coil is excited, the coil current is increased, and the current path is, for example, I_1 , when TR2 is turned off, the contactor coil is demagnetized by the diode D3, and the coil current is reduced. The chip detects the current of the contactor coil through the CSH and CSL pins, and adjusts the duty cycle in real time to adjust the coil current.

(3) Figure 8, In the turn-off stage, see the circuit schematic of the shutdown phase. The MOS transistor TR2 is not turned on, and the FO will draw the current of the capacitor C4. The path of the current sinking I_{FO_OFF} is as follows: the current of the C4 is drawn through of the MOS transistor TR1. At this time, the MOS transistor TR1 operates in the sub-threshold state, and the drain terminal voltage of the MOS transistor TR1 is relatively large, and the voltage value is $V_{TH} + V_{D2} + V_{DZ}$, wherein V_{TH} is the conduction threshold voltage of TR1, V_{D2} is forward voltage drop of diode D2 and V_{DZ} is the voltage regulation value of the Zener diode DZ. At this time, the demagnetization voltage of the contactor coil becomes large, the coil current is attenuated quickly, and finally the effect of fast turn-off is achieved.

Extended Output Design

The fast turn-off function is not necessary. In the case where the turn-off time is not required, the circuit of the fast turn-off part can be removed, such as circuit expansion one.

Remotely turn off non-essential functions. Without this requirement, the remote shutdown part of the circuit can be removed, and the system can work normally, such as circuit expansion two.

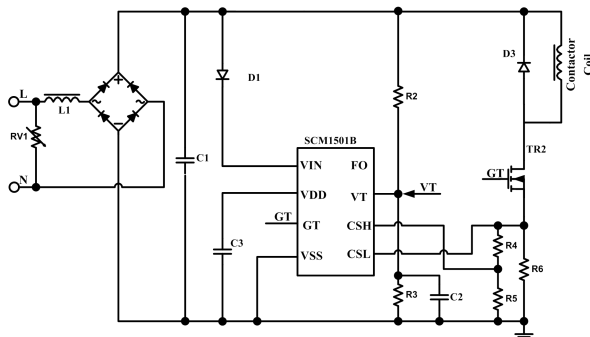

Fig. 9 Expansion circuit one

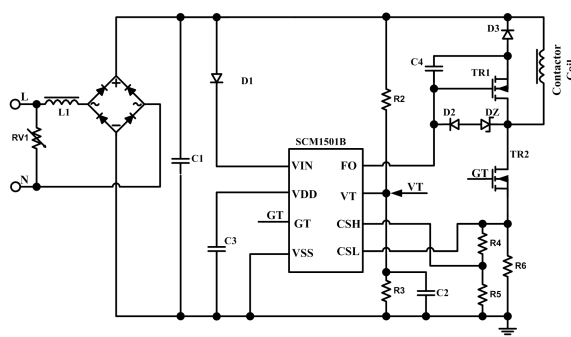

Fig. 10 Expansion circuit two

Application Circuit

The application circuit is a general conventional application and has no remote shutdown function. The circuit can start or turn off the contactor by comparing the input voltage with the threshold of VT pin.

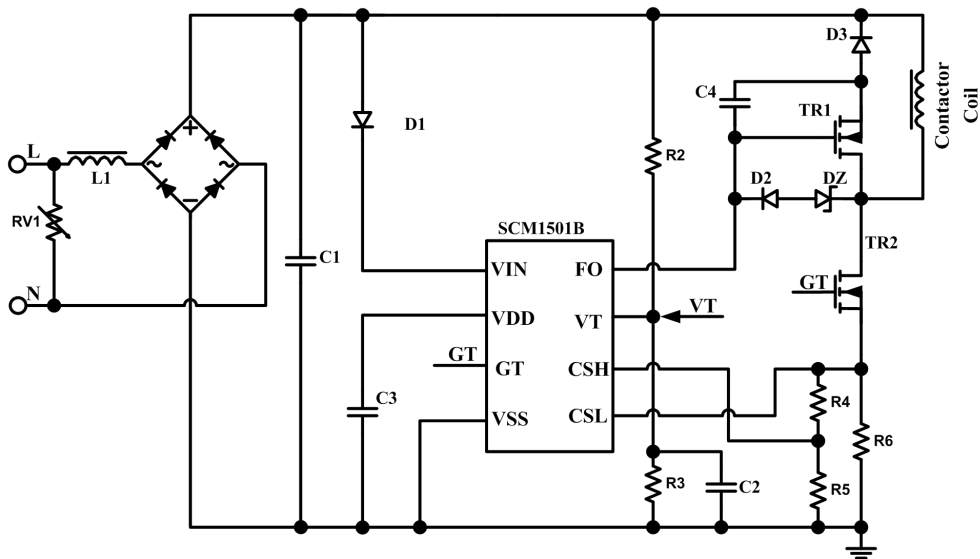

Fig. 11 Application circuit one

For the need of intelligent control, an optocoupler can be added to achieve remote control, and the high and low level signals are used to control the start and stop of the contactor. When the input is high, the VT pin is pulled low by the optocoupler and the contactor is turned off. When the input is low and the VT pin voltage reaches the startup threshold, the contactor will start.

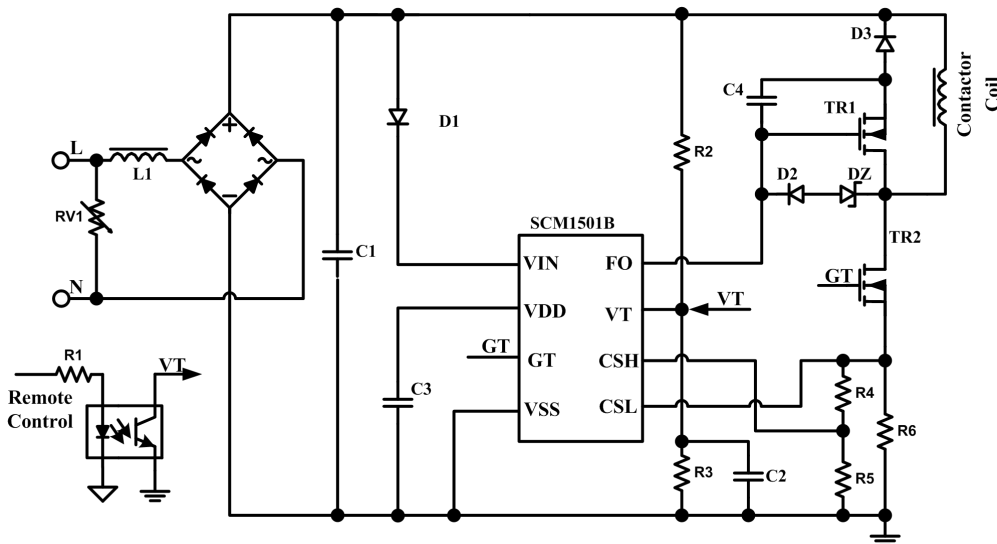

Fig. 12 Application circuit two

Product Model Overview

The SCM1501B is a contractor power-saving controller that reduces the pick-up and holding power consumption of the contactor.

The SCM1501B has a built-in high-voltage startup circuit that can quickly start the controller with a charging current of 4mA (typ.) within the input voltage range of 16.5V~500V, so as to respond quickly when the contactor is operated. If the auxiliary power supply is not used, SCM1501B will take power directly from the input to realize self-power supply. In addition, the SCM1501B can also control the contactor coil to achieve high current pick-up and low current holding. During the low current holding stage, when the input undervoltage occurs or the the controller is disable, the controller activates the fast shutdown function to quickly disconnect the contactor to reduce the influence of the SCM1501B on the disconnecting performance of the contactor.

High Voltage Startup Operation

The SCM1501B is capable of taking power from the input voltage, charging the VDD bypass capacitor to V_{VDD_ON} with a current of 4mA (typ.) to output the GT drive signal, and then the LDO continues to supply the VDD bypass capacitor until $V_{VDD}=V_{VDD_HD}$. If there is no 18V~20V auxiliary power supply to the controller, the SCM1501B will continue to draw power from the input to maintain $V_{VDD}=V_{VDD_HD}$.

In AC applications, when the system is operating in the pick-up stage, the input voltage waveform is a head wave. A diode needs to be connected in series with the VIN pin. If necessary, a voltage divider resistor is connected in series to reduce the startup power consumption of the SCM1501B.

Current Design

The SCM1501B uses the CSL and CSH pins to set the peak current in the holding stage and the pick-up stage for programmable design, and the peak current ratio of the two stages ranges from 4 to 20 times wide. As shown in the typical application circuit, the peak currents of these two stages satisfy the following equation:

Peak current I_H during the pick-up stage:

$$I_H = \frac{V_{CSTH} \cdot (R4 + R5)}{R5 \cdot R6}$$

Peak current I_L during the holding stage:

$$I_L = \frac{V_{CSTL}}{R6}$$

It can be seen that by designing the ratio of R4 and R5, the programmable design of the ratio I_H/I_L of the peak current can be realized.

Input Undervoltage Protection

In the AC application, when the SCM1501B is started, if $V_{VT} < 1.6V$, the GT does not output the drive signal. When $V_{VT} > 2.4V$ and $V_{VDD_ON} \geq V_{VDD_ON}$, the GT starts to output the drive signal and enters the pick-up stage. Here 2.4V is the action voltage V_{ACT_AC} of contactor. In AC application, the return difference of V_{ACT_AC} is 0.8V, that is, the AC turn-off voltage $V_{OFF_AC} = 1.6V$ of contactor. When V_{VT} is less than 1.6V and lasts for 2ms, it enters the input undervoltage protection and turns off the driving signal output of GT. And depending on the state of the system, choose whether to let the fast shut-off transistor work in the sub-threshold area, as described in the section "Quick Shut down".

Pick-up/holding switchover

Taking AC applications as an example, when $V_{VT} > 2.4V$, start timing for 98 ms (if input under-voltage protection is entered during this period, the timing is cleared). SCM1501B transits from the pick-up stage to the holding stage, and from the CSH pin to the CSL pin effectively.

Switching Frequency

To avoid audible noise, the SCM1501B has an average switching frequency of 23.5 kHz. To optimize EMI characteristics, the instantaneous value of the controller's switching frequency is $\pm 6.5\%$ peak-to-peak jitter compared to the average.

Quick Shutdown

As shown in the typical application circuit, when the TR2 is turned on, the FO pin outputs 5 mA of current to charge the FO bootstrap capacitor C4, so that the fast turn-off transistor TR1 operates in a on state, so that to achieve small current slope demagnetization under normal operating conditions.

When the voltage of VT pin is detected to be less than 1.6V up to 0.66ms, and SCM1501B works in the holding stage. The peak slope voltage of CSL is 0.3V, the enable signal switches off the circuit quickly. The FO pin "extracts" 1.2mA current. At this time, the FO bootstrap capacitor C4 discharges until the fast switch-off TR1 works in the sub-threshold region, thus maintaining the slope of the inductance demagnetization current at $(V_Z + 2V_F + V_{TH})/L_M$ to reduce the delay of the contactor opening. V_Z is the clamp voltage of the regulator, V_F is the forward voltage of the diodes D1 and D2. It is considered that the forward voltage of D1 and D2 is the same, V_F is the threshold voltage of TR1 and L_M is the inductance of the inductive element L2.

After 98ms of the start of the enable signal generation, the fast shutdown circuit stops operating, thereby saving 1.2 mA of current. The 1.2 mA current has a parameter range of 0.989 mA to 1.6 mA due to process variations.

Recommendations

The VDD bypass capacitor C3 should be as close as possible to the VDD pin, and the gate capacitor C4 of the fast turn-off transistor TR1 should be as close as possible to TR1.

Ordering Information

Part Number	Package Type	No. of Pins	Silk Screen Marking	Reel information
SCM1501BSA	ESOP8	8	SCM1501BSA YM	3K/REEL

Product marking

SCM1501XYZ,

(1) SCM1501 = Product designation.

(2) X= Version information (Letter from A-Z).

(3) Y = Package definition, (S = ESOP package).

(4) Z = Operating temperature range (C = 0°C to +70°C, I = -40°C to +85°C, A = -40°C to +125°C, M = -55°C to +125°C).

(5) YM = Date code for product traceability, Y = code for production year, M = code for production month.

Silk Screen Information

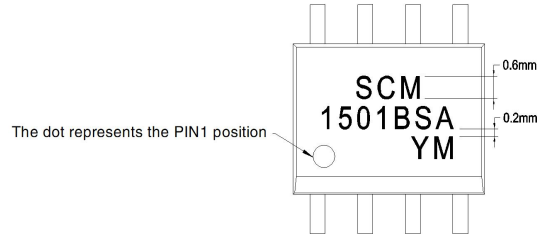

Note:

1、Typeface: Arial;

2、Character size:

Height: 0.6mm, Spacing: 0.1mm, LineSpacing: 0.2mm;

Mechanical Package Information

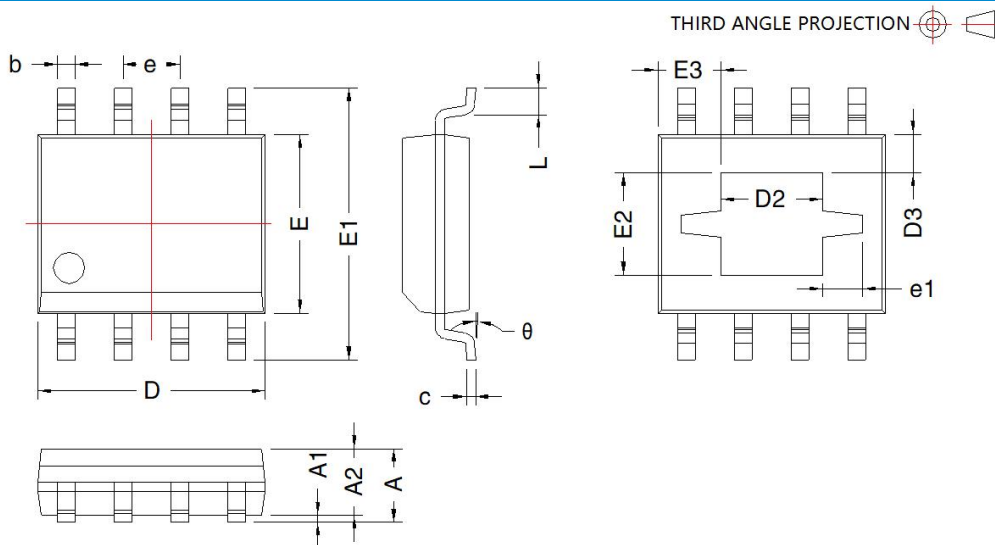

Mark	ESOP-8			
	Dimension(mm)		Dimension(inch)	
	Min	Max	Min	Max
A	1.5	1.7	0.059	0.067
A1	0.05	0.15	0.002	0.006
A2	1.3	1.5	0.051	0.059
D	4.7	5.1	0.185	0.201
E	3.8	4.0	0.150	0.157
E1	5.8	6.2	0.228	0.244
L	0.55	0.75	0.022	0.030
b	0.33	0.47	0.013	0.019
e	1.27TYP		0.05TYP	
c	0.2	0.25	0.0079	0.010
θ	0°	8°	0°	8°
D2	2.29		0.090	
D3	0.76	0.86	0.030	0.034
E2	2.29		0.090	
E3	1.21	1.41	0.048	0.056
e1	0.51		0.020	

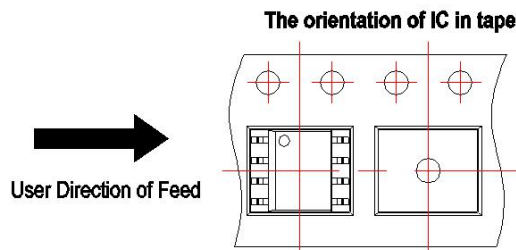
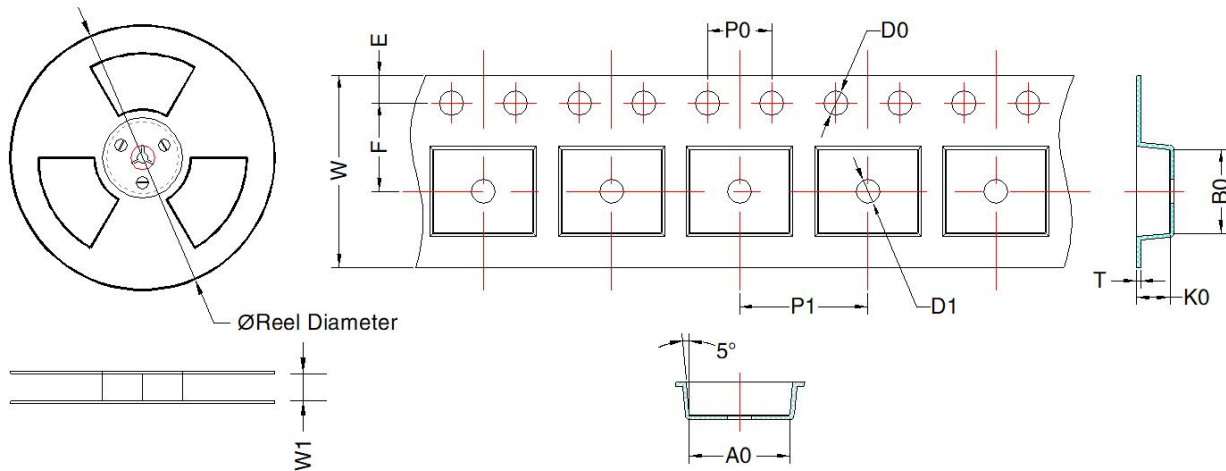

Device	Package Type	MPQ	Reel Diameter (mm)	Reel Width W1 (mm)	A0 (mm)	B0 (mm)	K0 (mm)	T (mm)	W (mm)	E (mm)	F (mm)	P1 (mm)	P0 (mm)	D0 (mm)	D1 (mm)
SCM1501BSA	ESOP-8	3000	330.0	12.4	6.5 ± 0.2	5.45 ± 0.2	2.0 ± 0.2	0.3 ± 0.05	12.0 ± 0.3	1.75 ± 0.1	5.5 ± 0.1	8.0 ± 0.1	4 ± 0.1	1.5 ± 0.1	1.5 ± 0.1

Mornsun Guangzhou Science & Technology Co., Ltd.

Address: No. 5, Kehui St. 1, Kehui Development Center, Science Ave., Guangzhou Science City, Huangpu District, Guangzhou, P. R. China

Tel: 86-20-38601850

Fax: 86-20-38601272

E-mail: info@mornsun.cn