

SCM3423ASA High-speed CAN Transceiver

Features

- Compatible with the "ISO 11898" standard fully
- Thermal Shutdown Protection
- Over current protection
- Transmit Data (TXD) Dominant Time-Out Function
- Silence mode
- An unpowered node does not disturb the bus lines
- The bus supports maximum 110 nodes
- High-speed CAN, Communication Speed up to 1Mbps
- High Electromagnetic Immunity

Applications

- Industrial automation
- Building automation
- Smart meter
- Long-distance signal interaction and transmission

Functional Description

The SCM3423ASA is an interface chip used between the CAN protocol controller and the physical bus. It can be used in many fields such as trucks, buses, cars, industrial control. It can reach speeds up to 1Mbps. The SCM3423ASA has the ability to differentially transmit between the bus and the CAN protocol controller.

Typical Application

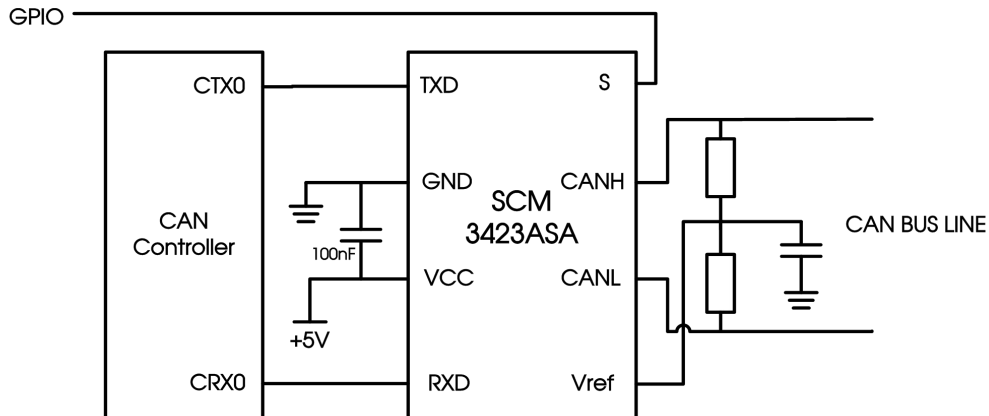

Note: GPIO means universal I/O port.

Package

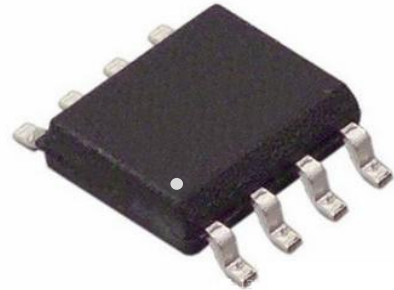

Product optional package: SOP-8, Screen Printing information please see "Order Information"

Contents

Feature and Package.....1	Electrical Characteristics.....3
Applications.....1	Switching Characteristics.....4
Functional Description.....1	Parameter Test Circuit.....4
Typical Application.....1	General Description.....6
Pin Package.....2	Design Circuit Expansion.....6
Truth Table.....2	Power Usage Recommendations.....6
Pin Configurations and Functions.....2	Ordering Information.....9
Absolute Maximum Ratings.....2	Package Information9
Recommended Operating Conditions.....3	Tape & Reel Information9

Pin Package

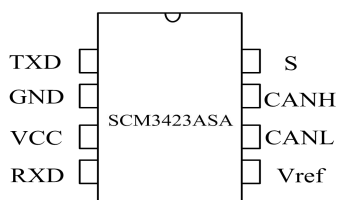

Truth Table

TABLE 1 CAN Transceiver Truth Table

VCC	TXD	S	CANH	CANL	BUS STATE	RXD
4.75 to 5.25V	L	L(Or left floating)	H	L	Dominant	L
4.75 to 5.25V	H(Or left floating)	X	0.5VCC	0.5VCC	Recessive	H
4.75 to 5.25V	X	H(Or left floating)	0.5VCC	0.5VCC	Recessive	H
0<VCC<4.75V	X	X	0V<VCANH<VCC	0V<VCANL<VCC	Recessive	X

(1)H=High-level ; L=Low-level ; X=Any level

TABLE 2 Device function table

INPUTS		OUTPUTS		Bus State
TXD	S	CANH	CANL	
L	L(or left floating)	H	L	Dominate
H (Or left floating)	X	Z	Z	Recessive
X	H	Z	Z	Recessive

(2)H=High-level ; L=Low-level ; X=Any level

TABLE 3 Receiver function table

VID=CANH-CANL	RXD	Bus State
VID≥0.9V	L	Dominate
0.5< VID<0.9V	?	?
VID≤0.5V	H	Recessive
Open	H	Recessive

(3)H=High-level ; L=Low-level; ? =indeterminacy

Pin Configurations and Functions

Pins	Name	Pin Functions
1	TXD	Transmit data input
2	GND	Ground supply
3	VCC	Supply voltage
4	RXD	Receive data output; reads out data from the bus lines
5	Vref	Reference output voltage
6	CANL	LOW-level CAN bus line
7	CANH	HIGH-level CAN bus line
8	S	Silence mode and high-speed mode (Low is high-speed)

Absolute Maximum Ratings

Sym.	Parameters	Value.	Unit.
V _{CC}	Supply Voltage	-0.3 to +6	V
TXD,RXD,Vref,S	MCU Side Port	-0.3 to V _{CC} +0.3	V
CANL, CANH, SPLIT	Bus Side Input Voltage	-40 to 40	V
V _{tr}	Transient Voltage on 6, 7 Pin (See Figure 7)	-200 to +200	V
	Storage Temperature Range	-55 to 150	°C
	Operating Ambient Temperature Range	-40 to 125	°C
	Welding Temperature Range	300	°C
SOP8	Continuous Power Dissipation	400	mW
DIP8		700	mW

The maximum limit parameter value means that exceeding these values may cause irreparable damage to the device. Under these conditions, it is not conducive to the normal operation of the device. Continuous operation of the device at the maximum allowable rating may affect device reliability. The reference point for all voltages is ground.

Recommended Operating Conditions

Parameters	Sym.	Test Conditions	Min.	Max.	Units
Supply Voltage	V _{CC}		4.75	5.25	V
Maximum Baud Rate	1/tbit	Non-return to zero code	1		Mbaud
CANH, CANL Input Voltage	V _{can}		-40	+40	V
BUS Differential Output Voltage	V _{diff}		1.5	3.0	V
Operating Ambient Temperature Range	T _{amb}		-40	125	°C

Electrical Characteristics

Unless otherwise stated, V_{CC}=5V±5%, Temp=T_{MIN}~T_{MAX}, typical value is V_{CC}=+5V, Temp=25°C

Driver Electrical Characteristics						
Sym.	Parameters	Test Conditions	Min.	Typ.	Max.	Units
V _{OH(D)}	CANH output voltage(dominant)	V _I =0V, STB=0V, R _L =60Ω , Figure 1, Figure 2	2.9	3.4	4.5	V
V _{OL(D)}	CANL output voltage(dominant)		0.8		1.5	V
V _{O(R)}	Output voltage(recessive)	V _I =3V, STB=0V, R _L =60Ω , Figure 1, Figure 2	2	2.5	3	V
V _{OD(D)}	Bus differential output voltage (dominant)	V _I =0V, S=0V, R _L =60Ω , Figure 1/Figure 2	1.5		3	V
V _{OD(R)}	Bus differential output voltage(recessive)	V _I =3V, S=0V , Figure 1, Figure 2	-0.012		0.012	V
		V _I =3V, S=0V, NO LOAD	-0.5		0.05	V
V _{dom(TX)sym}	Dominant output voltage symmetry	V _{dom(TX)sym} =V _{CC} - V _{CANH} - V _{CANL}	-400		400	mV
V _{TXsym}	Output voltage symmetry	V _{TXsym} = V _{CANH} + V _{CANL}	0.9V _{CC}		1.1V _{CC}	V
V _{OC}	Common-mode output voltage	S=0V, Figure 8	2	2.5	3	V
ΔV _{OC}	Dominant recessive common-mode output voltage difference			30		mV
I _{OS}	Short-circuit output current	CANH=-12V, CANL=open , Figure 11	-105	-72		mA
		CANH=12V, CANL=open , Figure 11		0.36	1	
		CANL=-12V, CANH=open , Figure 11	-1	0.5		
		CANL=12V, CANH=open , Figure 11		71	105	
I _{O(R)}	Output current(recessive)	-27V<CANH<32V 0<V _{CC} <5.25V	-2.0		2.5	mA

Receiver Electrical Characteristics

Sym.	Parameters	Test Conditions	Min.	Typ.	Max.	Units
V _{IT+}	Positive-going input threshold voltage	S=0V, Figure5		800	900	mV
V _{IT-}	Negative-going input threshold voltage		500	650		
V _{HYS}	Hysteresis voltage (V _{IT+} - V _{IT-})		100	125		
V _{OH}	High-level output voltage	I _O =-2mA, Figure6	4	4.6		V
V _{OL}	Low-level output voltage	I _O =2mA, Figure6		0.2	0.4	V
I _(OFF)	Unpowered input current	CANH or CANL=5V , Other pin=0V		162	250	μA
C _I	Input capacitance to ground (CANH or CANL)			13		pF
C _{ID}	Differential input capacitance			5		pF
R _{IN}	Input resistance (CANH or CANL)	TXD=3V, STB=0V	15	30	40	KΩ
R _{ID}	Differential input resistance		30		80	
R _{I_{match}}	Input resistance matching: [1 - R _{IN} (CANH) / R _{IN} (CANL)] × 100%	CANH=CANL	-3%		3%	
V _{COM}	Common mode range		-12		12	V

Power Supply Features

Sym.	Parameters	Test Conditions	Min.	Typ.	Max.	Units
I _{CC}	Standby mode power dissipation	S=V _{CC} , V _I =V _{CC}		6	10	μA
	Dominant power dissipation	V _I =0V, S=0V, LOAD=60Ω		50	70	mA
	Recessive power dissipation	V _I =V _{CC} , S=0V, NO LOAD		6	10	mA

Switching Characteristics

Unless otherwise stated, V_{CC}=5V±5%, Temp=T_{MIN}~T_{MAX}, typical value is V_{CC}=+5V, Temp=25°C

Driver Switching Characteristics						
Sym.	Parameters	Test Conditions	Min.	Typ.	Max.	Units
t _{PLH}	Driver propagation delay(L to H)	STB=0V, Figure4	25	65	120	ns
t _{PHL}	Driver propagation delay(H to L)		25	45	90	ns
t _r	Driver differential-output rise time			25		ns
t _f	Driver differential-output fall time			50		ns
t _{EN}	Delay time from listening mode to dominant enable	Figure7			1	μs
t _{dom}	Dominant time-out time	Figure10	300	450	700	μs
Receiver Switching Characteristics						
Sym.	Parameters	Test Conditions	Min.	Typ.	Max.	Units
t _{PLH}	Receiver propagation delay(L to H)	S=0V or V _{CC} , Figure6	60	100	130	ns
t _{PHL}	Receiver propagation delay(H to L)		45	70	90	ns
t _r	Receiver output rise time			8		ns
t _f	Receiver output fall time			8		ns
Device Switching Characteristics						
T _{d(LOOP1)}	Total loop delay1, driver input (TXD) to receiver output (RXD), recessive to dominant	Figure9, S=0V	90		190	ns
T _{d(LOOP2)}	Total loop delay2, driver input (TXD) to receiver output (RXD), dominant to recessive		90		190	ns

Other Characteristics

Unless otherwise stated, V_{CC}=5V±5%, Temp=T_{MIN}~T_{MAX}, typical value is V_{CC}=+5V, Temp=25°C

Over Temperature Protection						
Sym.	Parameters	Test Conditions	Min.	Typ.	Max.	Units
T _{J(sd)}	Thermal shutdown of bus drivers			160		°C
TXD Characteristics						
Sym.	Parameters	Test Conditions	Min.	Typ.	Max.	Units
I _{IH(TXD)}	TXD Pin High-level input current	V _I =V _{CC}	-2		2	μA
I _{IL(TXD)}	TXD Pin Low-level input current	V _I =0	-50		-10	μA
I _{O(off)}	V _{CC} =0V, Current of TXD	V _{CC} =0V, TXD=5V			1	μA
V _{IH}	High-level input voltage		2		V _{CC} +0.3	V
V _{IL}	Low-level input voltage		-0.3		0.8	V
TXDO	TXD port suspension voltage			H		logic
Common Stable Output						
Sym.	Parameters	Test Conditions	Min.	Typ.	Max.	Units

V_{ref}	Reference output voltage	$-50\mu A < I_o < 50\mu A$	$0.4V_{CC}$	$0.6V_{CC}$	V
-----------	--------------------------	----------------------------	-------------	-------------	---

Parameter Test Circuit

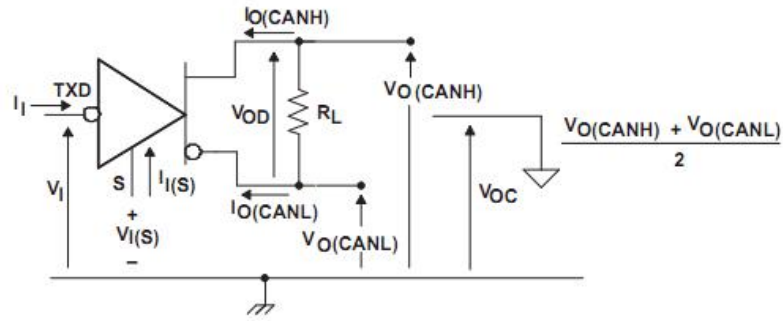

Figure 1. The driver voltage, current test defines

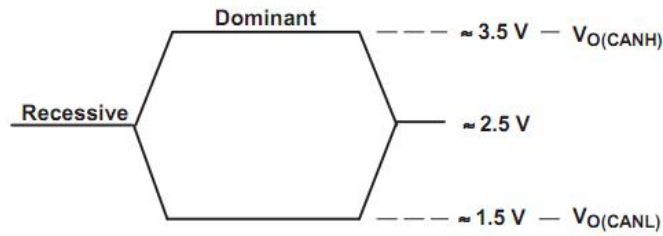

Figure 2. Bus logic voltage defines

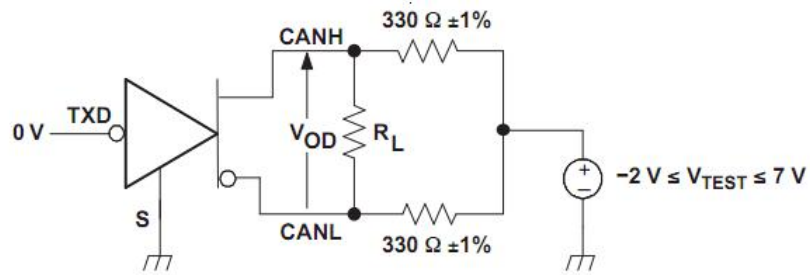

Figure3. Driver VOD testings telephone

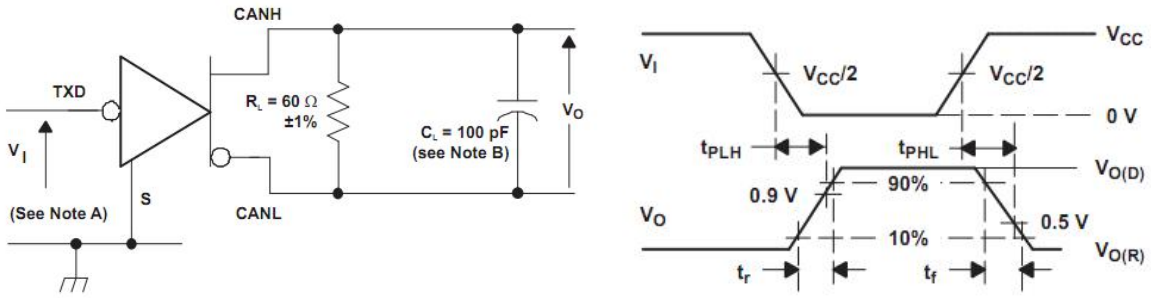

Figure 4. The driver testings telephone and electricity corrugating

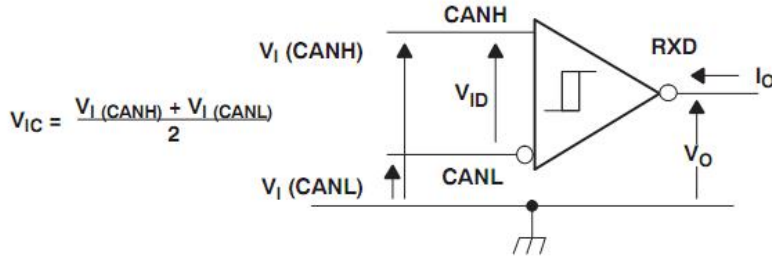
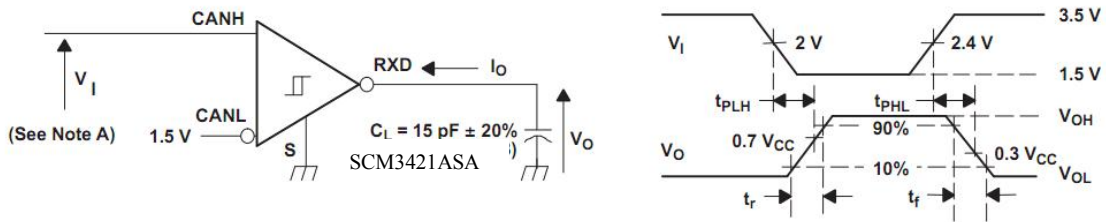

Figure 5. Receiver voltage and current definition



- A. Input pulse generator characteristics: $PRR \leq 125\text{KHz}$, duty cycle = 50%, $t_r < 6\text{ns}$, $t_f < 6\text{ns}$, $Z_o = 50\Omega$
 B. C_L includes instrument and fixed capacitor, the error is within 20%.

Figure 6. Receiver test telephone and electricity corrugating

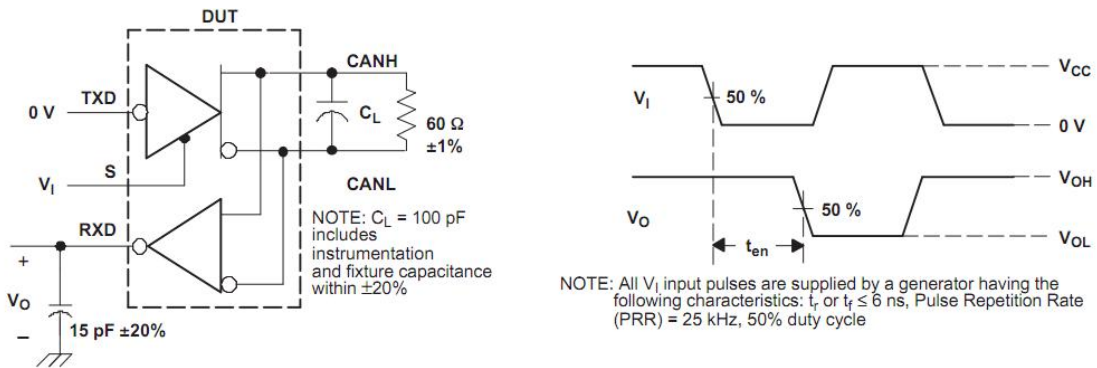

Figure 7. tEN test circuit and electricity corrugating

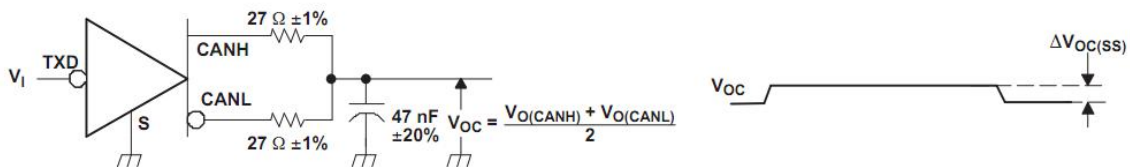

Figure 8. Common mode output voltage test and waveform

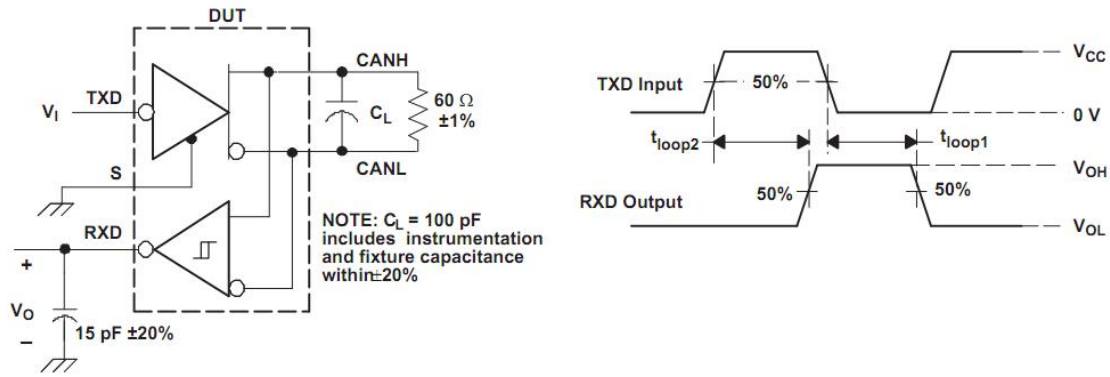

Figure 9. t(LOOP) Test Circuit and waveform

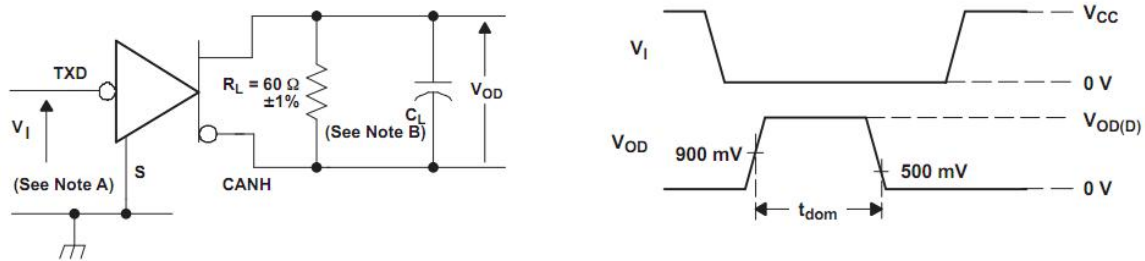

Figure 10. Dominant time-out test circuit and waveform

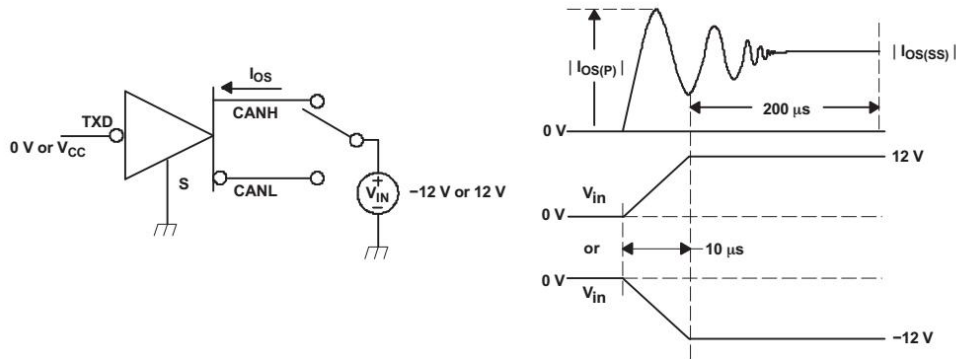

Figure 11. The driver short-circuit current test Circuit and waveform

General Description

The SCM3423ASA is an interface chip used between the CAN protocol controller and the physical bus. It can be used in many fields such as trucks, buses, cars, industrial control. It can reach speeds up to 1Mbps. The SCM3423ASA has the ability to differentially transmit between the bus and the CAN protocol controller. SCM3423ASA is compatible with the "ISO 11898" standard.

Short-circuit protection: The drive stage of the SCM3422ASA has current-limiting protection to prevent the drive circuit from short-circuiting to positive and negative supply voltages. The power dissipation increases when a short circuit occurs. The short-circuit protection function protects the driver stage from damage.

Over-temperature protection: The SCM3423ASA has over-temperature protection. When the junction temperature exceeds 160°C, the current in the driver stage will decrease. Because the drive tube is the primary energy consuming component, current reduction can reduce power consumption and reduce chip temperature. At the same time, the rest of the chip remains functional.

Dominant time-out function: If the pin TXD is forced to a permanent low level due to a hardware or software application failure, the built-in TXD dominant timeout timer circuit prevents the bus line from being driven to a permanent dominant state (blocking all network traffic). The timer is triggered by the negative edge on pin TXD.

If the low level on pin TXD lasts longer than the internal timer value (t_{dom}), the transmitter will be disabled and the drive bus will enter a recessive state. The timer is reset by the positive edge on pin TXD.

Control mode: Control pin S allows two operating modes to be selected: high speed mode or silent mode.

The high speed mode is the normal operating mode and is selected by grounding the pin S. If pin S is not connected, it is the default mode. However, to ensure EMI performance in applications that only use high speed mode, it is recommended to ground pin S.

In silent mode, the transmitter is disabled. All other IC functions continue to run. The silent mode is selected by connecting pin S to VCC and can be used to prevent network communication congestion due to out of control of the CAN controller.

Design Circuit Expansion

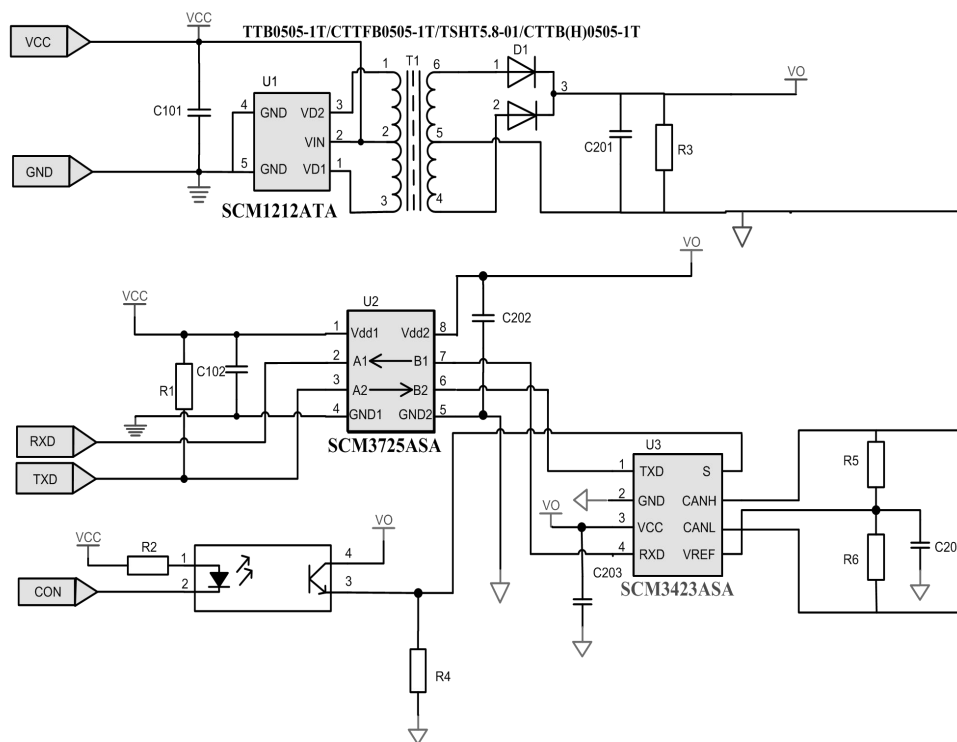

Figure 12. Isolated Application Circuit Schematic for Converting TTL/CMOS to CAN Bus

Power Usage Recommendations

Connecting the 0.1 μ F bypass capacitor as close as possible to the VCC pin of the device.

Ordering Information

Product number	Package Type	Pins	Screen Printing	package
SCM3423ASA	SOP	8	SCM 3423ASA YM	2.5K/reel

Product model and Screen Printing instructions:

SCM3423XYZ:

(1)SCM3423, Product Code.

(2)X = A-Z, Version code.

(3)Y = S Package code; S: SOP package.

(4)Z = C, I, A, M, Temperature class code; C: 0 $^{\circ}$ C - 70 $^{\circ}$ C, I: -40 $^{\circ}$ C - 85 $^{\circ}$ C, A: -40 $^{\circ}$ C - 125 $^{\circ}$ C, M: -55 $^{\circ}$ C - 125 $^{\circ}$ C.

(5)YM: Product traceability code; Y: Product year code, M: Product production month code.

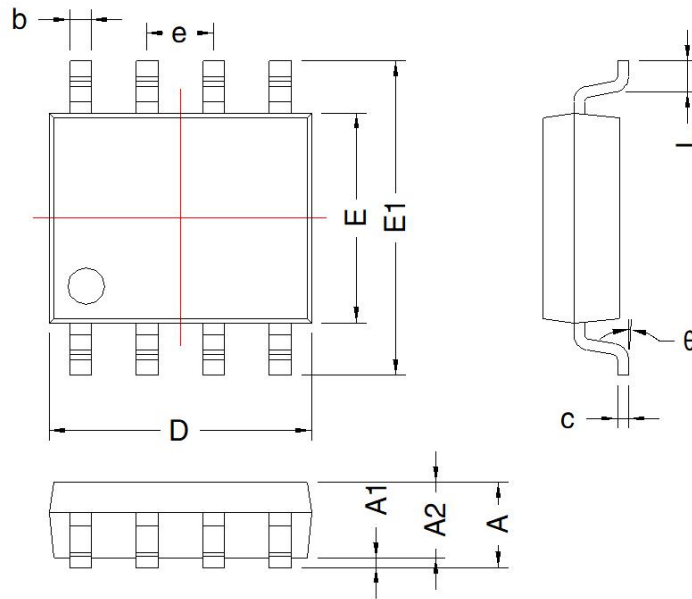

SOP-8				
Mark	Dimension(mm)		Dimension(inch)	
	Min	Max	Min	Max
A	1.5	1.7	0.059	0.067
A1	0.1	0.2	0.004	0.008
A2	1.35	1.55	0.004	Min
D	4.8	5.0	0.053	0.197
E	3.78	3.98	0.149	0.157
E1	5.8	6.2	0.228	0.244
L	0.4	0.8	0.016	0.031
b	0.355	0.455	0.014	0.018
e	1.27 TYP		0.05 TYP	
c	0.153	0.253	0.006	0.001
θ	2°	6°	2°	6°

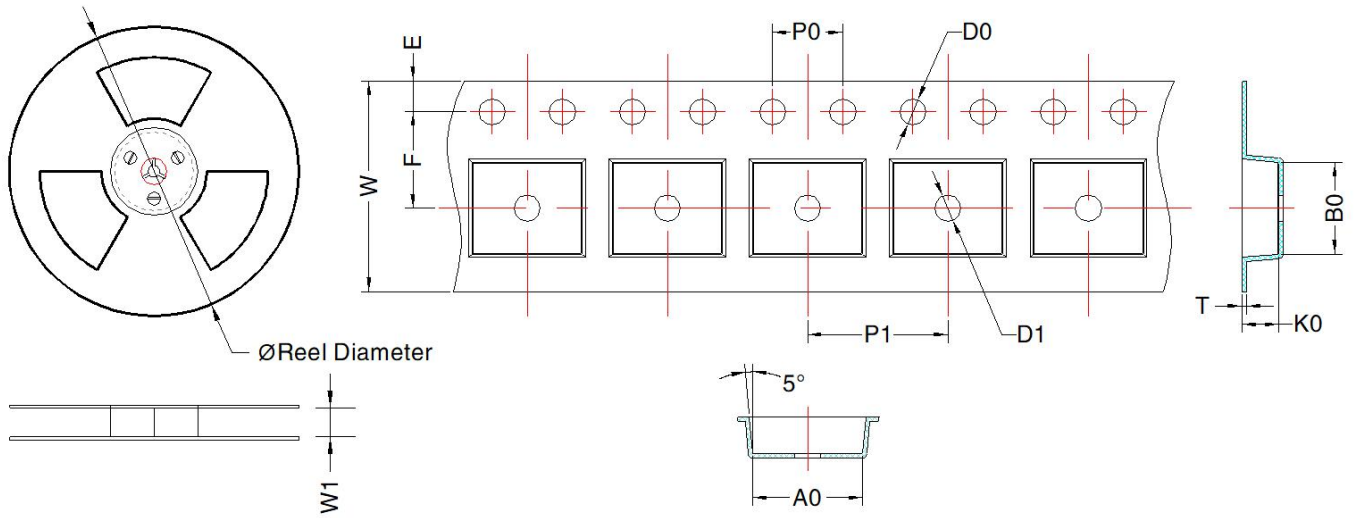

The orientation of IC in tape

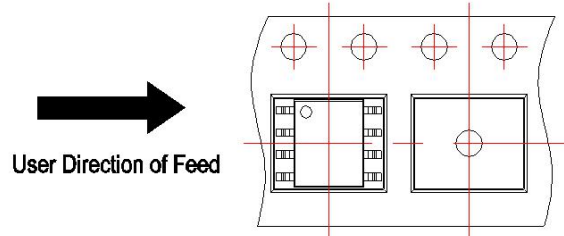

Device	Package Type	MPQ	Reel Diameter (mm)	Reel Width W1 (mm)	A0 (mm)	B0 (mm)	K0 (mm)	T (mm)	W (mm)	E (mm)	F (mm)	P1 (mm)	P0 (mm)	D0 (mm)	D1 (mm)
SCM3423ASA	SOP-8	2500	330.0	12.4	6.4±0.1	5.3±0.1	2.1±0.1	0.25±0.03	12.0±0.1	1.75±0.1	5.5±0.1	8±0.1	4±0.1	1.5±0.1	1.5±0.1

MORNSUN Guangzhou Science & Technology Co., Ltd.

Address: No. 5, Kehui St. 1, Kehui Development Center, Science Ave., Guangzhou Science City, Huangpu District, Guangzhou, P. R. China
 Tel: 86-20-38601850 Fax: 86-20-38601272 E-mail: info@mornsun.cn www.mornsun-power.com