

National Semiconductor is now part of
Texas Instruments.

Search <http://www.ti.com/> for the latest technical
information and details on our current products and services.

ADC0844/ADC0848

8-Bit μ P Compatible A/D Converters with Multiplexer Options

General Description

The ADC0844 and ADC0848 are CMOS 8-bit successive approximation A/D converters with versatile analog input multiplexers. The 4-channel or 8-channel multiplexers can be software configured for single-ended, differential or pseudo-differential modes of operation.

The differential mode provides low frequency input common mode rejection and allows offsetting the analog range of the converter. In addition, the A/D's reference can be adjusted enabling the conversion of reduced analog ranges with 8-bit resolution.

The A/Ds are designed to operate from the control bus of a wide variety of microprocessors. TRI-STATE[®] output latches that directly drive the data bus permit the A/Ds to be configured as memory locations or I/O devices to the microprocessor with no interface logic necessary.

Features

- Easy interface to all microprocessors
- Operates ratiometrically or with 5 V_{DC} voltage reference
- No zero or full-scale adjust required
- 4-channel or 8-channel multiplexer with address logic
- Internal clock
- 0V to 5V input range with single 5V power supply
- 0.3" standard width 20-pin or 24-pin DIP
- 28 Pin Molded Chip Carrier Package

Key Specifications

- Resolution: 8 Bits
- Total Unadjusted Error: $\pm 1/2$ LSB and ± 1 LSB
- Single Supply: 5 V_{DC}
- Low Power: 15 mW
- Conversion Time: 40 μ s

Block and Connection Diagrams

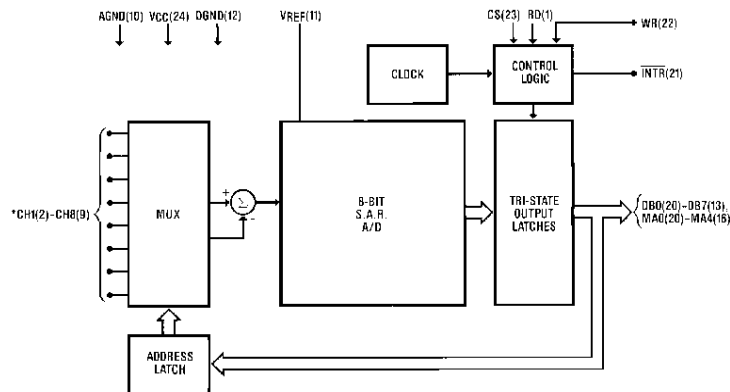

DS005016-1

*ADC0848 shown in DIP Package CH5-CH8 not included on the ADC0844

TRI-STATE[®] is a registered trademark of National Semiconductor Corp.

Block and Connection Diagrams (Continued)

Molded Chip Carrier Package

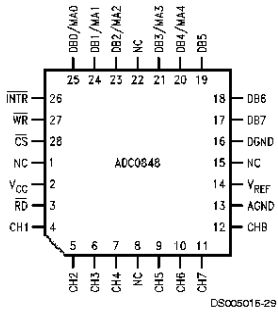

Top View
See Ordering Information

Dual-In-Line Package

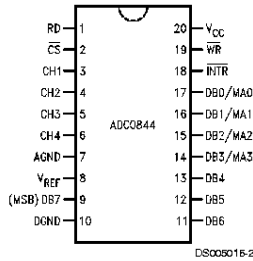

Top View

Dual-In-Line Package

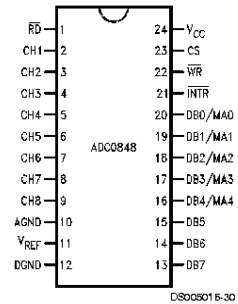

Top View

Absolute Maximum Ratings (Notes 1, 2)

If Military/Aerospace specified devices are required, please contact the National Semiconductor Sales Office/Distributors for availability and specifications.

Supply Voltage (V_{CC})	6.5V
Voltage	
Logic Control Inputs	-0.3V to +15V
At Other Inputs and Outputs	-0.3V to $V_{CC}+0.3V$
Input Current at Any Pin (Note 3)	5 mA
Package Input Current (Note 3)	20 mA
Storage Temperature	-65°C to +150°C
Package Dissipation at $T_A=25^\circ\text{C}$	875 mW
ESD Susceptibility (Note 4)	800V

Lead Temperature

(Soldering, 10 seconds)	
Dual-In-Line Package (Plastic)	260°C
Dual-In-Line Package (Ceramic)	300°C
Molded Chip Carrier Package	
Vapor Phase (60 seconds)	215°C
Infrared (15 seconds)	220°C

Operating Conditions (Notes 1, 2)

Supply Voltage (V_{CC})	4.5 V_{DC} to 6.0 V_{DC}
Temperature Range	$T_{MIN} \leq T_A \leq T_{MAX}$
ADC0844BCN, ADC0844CCN,	$0^\circ\text{C} \leq T_A \leq 70^\circ\text{C}$
ADC0848BCN, ADC0848CCN	
ADC0844BCJ, ADC0844CCJ,	$-40^\circ\text{C} \leq T_A \leq 85^\circ\text{C}$
ADC0848BCJ, ADC0848CCJ	
ADC0848BCV, ADC0848CCV	

Electrical Characteristics

The following specifications apply for $V_{CC} = 5 V_{DC}$ unless otherwise specified. **Boldface limits apply from T_{MIN} to T_{MAX} ; all other limits $T_A = T_J = 25^\circ\text{C}$.**

Parameter	Conditions	ADC0844BCJ ADC0844CCJ ADC0848BCJ ADC0848CCJ			ADC0844BCN, ADC0844CCN ADC0848BCN, ADC0848CCN ADC0848BCV, ADC0848CCV			Limit Units
		Typ (Note 5)	Tested Limit (Note 6)	Design Limit (Note 7)	Typ (Note 5)	Tested Limit (Note 6)	Design Limit (Note 7)	
CONVERTER AND MULTIPLEXER CHARACTERISTICS								
Maximum Total Unadjusted Error	$V_{REF}=5.00 V_{DC}$ (Note 8)							
ADC0844BCN, ADC0848BCN, BCV			$\pm\frac{1}{2}$			$\pm\frac{1}{2}$	$\pm\frac{1}{2}$	LSB
ADC0844BCJ, ADC0848BCJ			$\pm\frac{1}{2}$			± 1	± 1	LSB
ADC0844CCN, ADC0848CCN, CCV			± 1			± 1	± 1	LSB
ADC0844CCJ, ADC0848CCJ			± 1			± 1	± 1	LSB
Minimum Reference Input Resistance		2.4	1.1		2.4	1.2	1.1	k Ω
Maximum Reference Input Resistance		2.4	5.9		2.4	5.4	5.9	k Ω
Maximum Common-Mode Input Voltage	(Note 9)		$V_{CC}+0.05$			$V_{CC}+0.05$	$V_{CC}+0.05$	V
Minimum Common-Mode Input Voltage	(Note 9)		$GND-0.05$			$GND-0.05$	$GND-0.05$	V
DC Common-Mode Error	Differential Mode	$\pm 1/16$	$\pm\frac{1}{4}$		$\pm 1/16$	$\pm\frac{1}{4}$	$\pm\frac{1}{4}$	LSB
Power Supply Sensitivity	$V_{CC}=5V \pm 5\%$	$\pm 1/16$	$\pm\frac{1}{8}$		$\pm 1/16$	$\pm\frac{1}{8}$	$\pm\frac{1}{8}$	LSB
Off Channel Leakage Current	(Note 10)							
On Channel=5V, Off Channel=0V			-1			-0.1	-1	μA
On Channel=0V, Off Channel=5V			1			0.1	1	μA
DIGITAL AND DC CHARACTERISTICS								
$V_{IN(1)}$, Logical "1" Input Voltage (Min)	$V_{CC}=5.25V$		2.0			2.0	2.0	V
$V_{IN(0)}$, Logical "0" Input Voltage (Max)	$V_{CC}=4.75V$		0.8			0.8	0.8	V
$I_{IN(1)}$, Logical "1" Input Current (Max)	$V_{IN}=5.0V$	0.005	1		0.005		1	μA

Electrical Characteristics (Continued)

The following specifications apply for $V_{CC} = 5 V_{DC}$ unless otherwise specified. **Boldface limits apply from T_{MIN} to T_{MAX}** ; all other limits $T_A = T_J = 25^\circ C$.

Parameter	Conditions	ADC0844BCJ			ADC0844BCN, ADC0844CCN ADC0848BCN, ADC0848CCN ADC0848BCV, ADC0848CCV			Limit Units
		Typ (Note 5)	Tested Limit (Note 6)	Design Limit (Note 7)	Typ (Note 5)	Tested Limit (Note 6)	Design Limit (Note 7)	
DIGITAL AND DC CHARACTERISTICS								
$I_{IN(0)}$, Logical "0" Input Current (Max)	$V_{IN}=0V$	-0.005	-1		-0.005		-1	μA
$V_{OUT(1)}$, Logical "1" Output Voltage (Min)	$V_{CC}=4.75V$ $I_{OUT}=-360 \mu A$ $I_{OUT}=-10 \mu A$		2.4			2.8	2.4	V
			4.5			4.6	4.5	V
$V_{OUT(0)}$, Logical "0" Output Voltage (Max)	$V_{CC}=4.75V$ $I_{OUT}=1.6 mA$		0.4			0.34	0.4	V
I_{OUT} , TRI-STATE Output Current (Max)	$V_{OUT}=0V$ $V_{OUT}=5V$	-0.01	-3		-0.01	-0.3	-3	μA
		0.01	3		0.01	0.3	3	μA
I_{SOURCE} , Output Source Current (Min)	$V_{OUT}=0V$	-14	-6.5		-14	-7.5	-6.5	mA
I_{SINK} , Output Sink Current (Min)	$V_{OUT}=V_{CC}$	16	8.0		16	9.0	8.0	mA
I_{CC} , Supply Current (Max)	$\overline{CS}=1, V_{REF}$ Open	1	2.5		1	2.3	2.5	mA

AC Electrical Characteristics

The following specifications apply for $V_{CC} = 5V_{DC}$, $t_r = t_f = 10 ns$ unless otherwise specified. **Boldface limits apply from T_{MIN} to T_{MAX}** ; all other limits $T_A = T_J = 25^\circ C$.

Parameter	Conditions	Typ (Note 5)	Tested Limit (Note 6)	Design Limit (Note 7)	Units
t_C , Maximum Conversion Time (See Graph)		30	40	60	μs
$t_{W(WR)}$, Minimum \overline{WR} Pulse Width	(Note 11)	50	150		ns
t_{ACC} , Maximum Access Time (Delay from Falling Edge of \overline{RD} to Output Data Valid)	$C_L = 100 pF$ (Note 11)	145		225	ns
t_{1H}, t_{0H} , TRI-STATE Control (Maximum Delay from Rising Edge of \overline{RD} to Hi-Z State)	$C_L = 10 pF, R_L = 10k$ (Note 11)	125		200	ns
t_{WI}, t_{RI} , Maximum Delay from Falling Edge of \overline{WR} or \overline{RD} to Reset of \overline{INTR}	(Note 11)	200	400		ns
t_{DS} , Minimum Data Set-Up Time	(Note 11)	50	100		ns
t_{DH} , Minimum Data Hold Time	(Note 11)	0	50		ns
C_{IN} , Capacitance of Logic Inputs		5			pF
C_{OUT} , Capacitance of Logic Outputs		5			pF

Note 1: Absolute Maximum Ratings indicate limits beyond which damage to the device may occur. DC and AC electrical specifications do not apply when operating the device beyond its specified operating conditions.

Note 2: All voltages are measured with respect to the ground pins.

Note 3: When the input voltage (V_{IN}) at any pin exceeds the power supply rails ($V_{IN} < V^-$ or $V_{IN} > V^+$) the absolute value of the current at that pin should be limited to 5 mA or less. The 20 mA package input current limits the number of pins that can exceed the power supply boundaries with a 5 mA current limit to four.

Note 4: Human body model, 100 pF discharged through a 1.5 k Ω resistor.

Note 5: Typicals are at 25°C and represent most likely parametric norm.

Note 6: Tested limits are guaranteed to National's AOQL (Average Outgoing Quality Level).

Note 7: Design limits are guaranteed by not 100% tested. These limits are not used to calculate outgoing quality levels.

Note 8: Total unadjusted error includes offset, full-scale, linearity, and multiplexer error.

Note 9: For $V_{IN} (-) \geq V_{IN}(+)$ the digital output code will be 0000 0000. Two on-chip diodes are tied to each analog input, which will forward-conduct for analog input voltages one diode drop below ground or one diode drop greater than V_{CC} supply. Be careful during testing at low V_{CC} levels (4.5V), as high level analog inputs (5V) can cause this input diode to conduct, especially at elevated temperatures, and cause errors for analog inputs near full-scale. The spec allows 50 mV forward bias

AC Electrical Characteristics (Continued)

of either diode. This means that as long as the analog V_{IN} does not exceed the supply voltage by more than 50 mV, the output code will be correct. To achieve an absolute 0 V_{DC} to 5 V_{DC} input voltage range will therefore require a minimum supply voltage of 4.950 V_{DC} over temperature variations, initial tolerance and loading.

Note 10: Off channel leakage current is measured after the channel selection.

Note 11: The temperature coefficient is 0.3%/°C.

Typical Performance Characteristics

Logic Input Threshold Voltage vs Supply Voltage

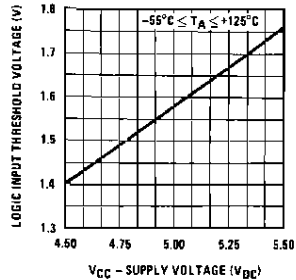

DS005016-31

Output Current vs Temperature

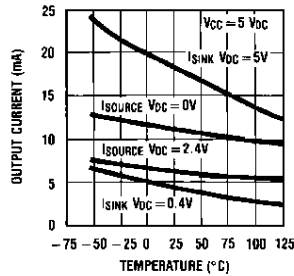

DS005016-32

Power Supply Current vs Temperature

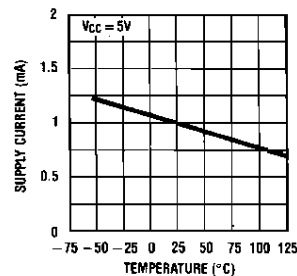

DS005016-33

Linearity Error vs V_{REF}

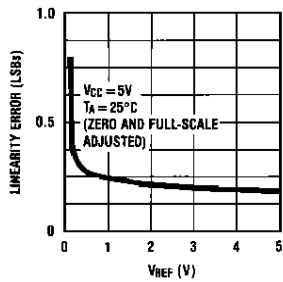

DS005016-34

Conversion Time vs V_{SUPPLY}

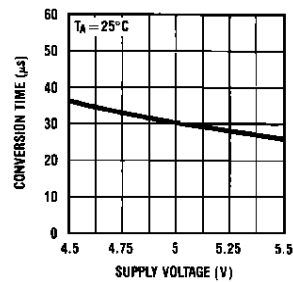

DS005016-35

Conversion Time vs Temperature

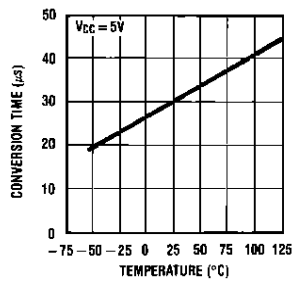

DS005016-36

Unadjusted Offset Error vs V_{REF} Voltage

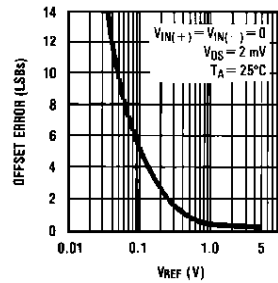

DS005016-37

TRI-STATE Test Circuits and Waveforms

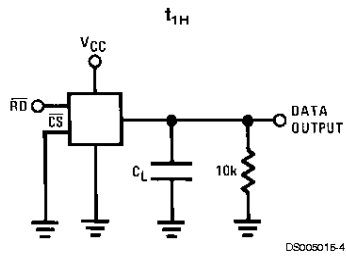

$t_r = 20 \text{ ns}$

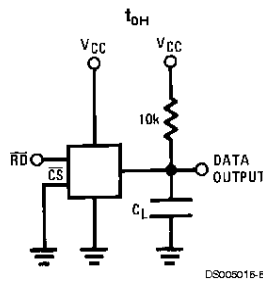
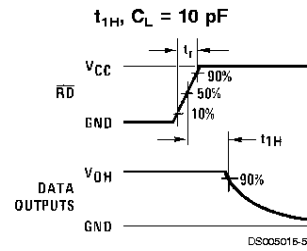

$t_r = 20 \text{ ns}$

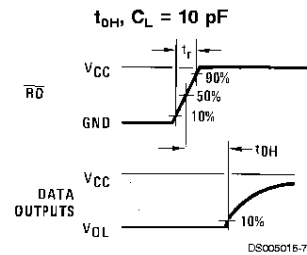

Leakage Current Test Circuit

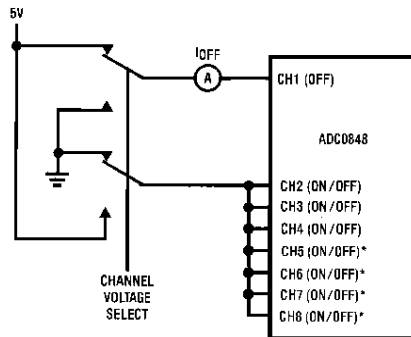

*NOT INCLUDED ON ADC0844

D5005015-8

Timing Diagrams

Programming New Channel Configuration and Starting a Conversion

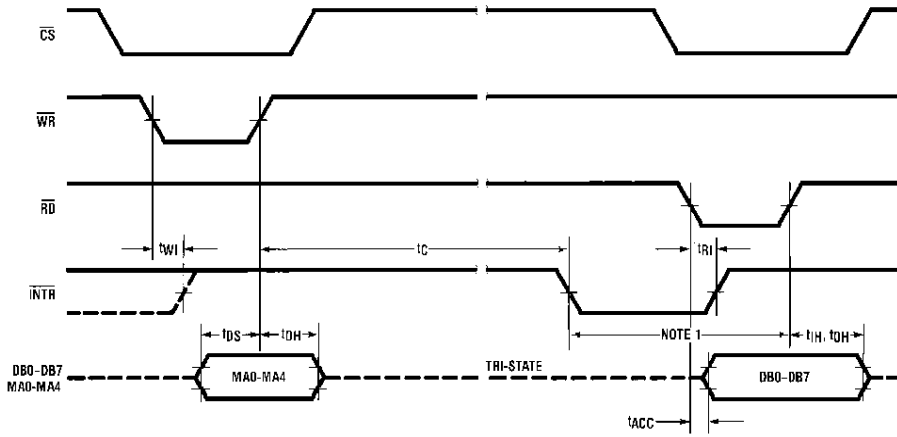

DS005018-9

Note 12: Read strobe must occur at least 600 ns after the assertion of interrupt to guarantee reset of \overline{INTR} .

Note 13: MA stands for MUX address.

Using the Previously Selected Channel Configuration and Starting a Conversion

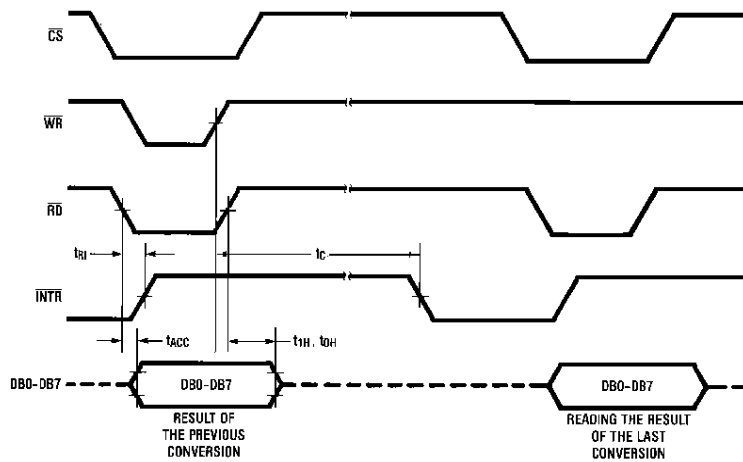

DS005018-10

ADC0848 Functional Block Diagram

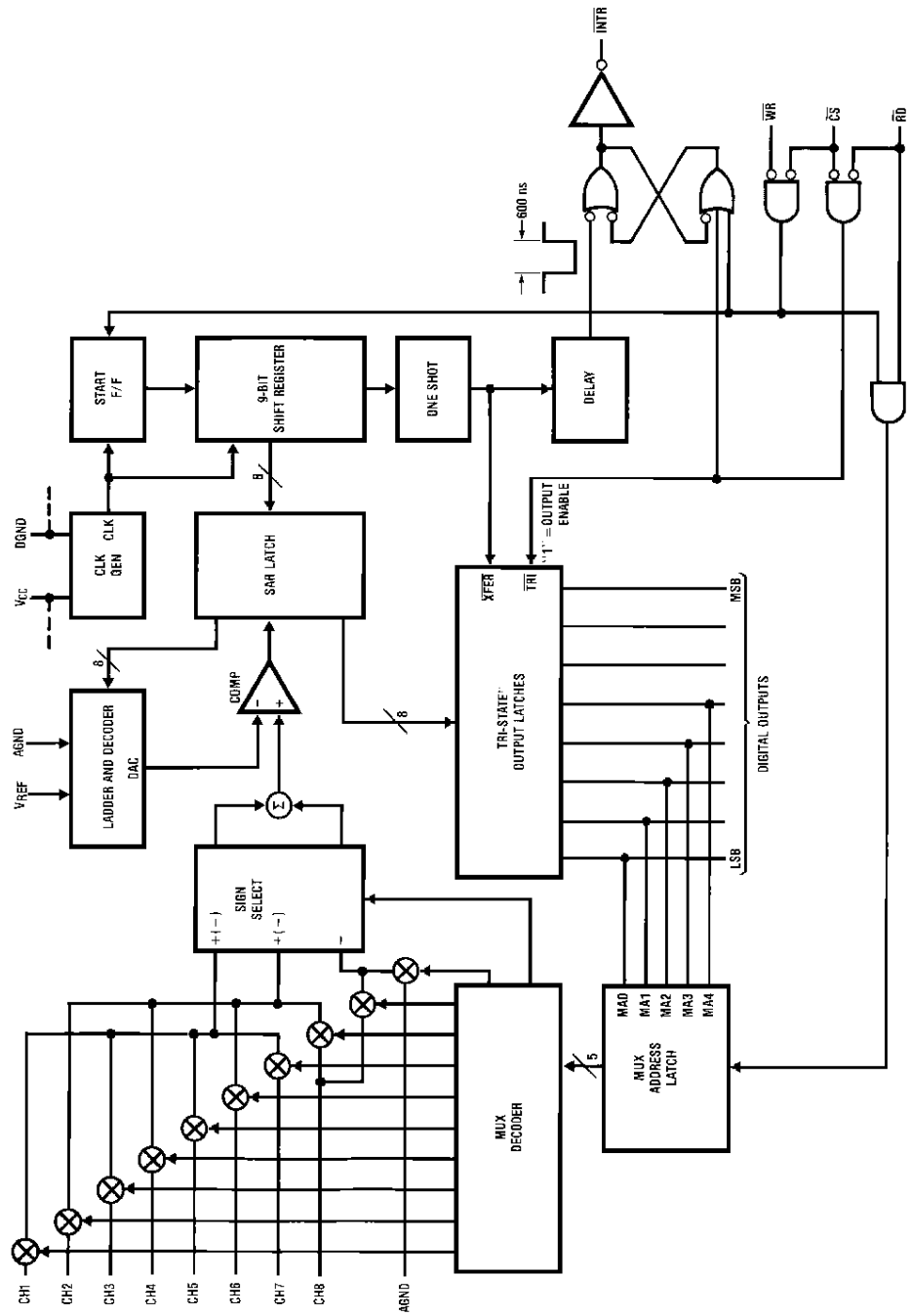

DS90C05/15-11

Functional Description

The ADC0844 and ADC0848 contain a 4-channel and 8-channel analog input multiplexer (MUX) respectively. Each MUX can be configured into one of three modes of operation differential, pseudo-differential, and single ended. These modes are discussed in the Applications Information Section. The specific mode is selected by loading the MUX address latch with the proper address (see *Table 1* and *Table 2*). Inputs to the MUX address latch (MA0-MA4) are common with data bus lines (DB0-DB4) and are enabled when the RD line is high. A conversion is initiated via the CS and WR lines. If the data from a previous conversion is not read, the INTR line will be low. The falling edge of WR will reset the INTR line high and ready the A/D for a conversion cycle. The rising edge of WR, with RD high, strobes the data on the MA0/DB0-MA4/DB4 inputs into the MUX address latch to select a new input configuration and start a conversion. If the RD line is held low during the entire low period of WR the previous MUX configuration is retained, and the data of the previous conversion is the output on lines DB0-DB7. After the conversion cycle ($t_c \leq 40 \mu s$), which is set by the internal clock frequency, the digital data is transferred to the output latch and the INTR is asserted low. Taking CS and RD low resets INTR output high and outputs the conversion result on the data lines (DB0-DB7).

Applications Information

1.0 MULTIPLEXER CONFIGURATION

The design of these converters utilizes a sampled-data comparator structure which allows a differential analog input to be converted by a successive approximation routine.

The actual voltage converted is always the difference between an assigned "+" input terminal and a "-" input terminal. The polarity of each input terminal of the pair being converted indicates which line the converter expects to be the most positive. If the assigned "+" input is less than the "-" input the converter responds with an all zeros output code.

A unique input multiplexing scheme has been utilized to provide multiple analog channels. The input channels can be software configured into three modes: differential, single ended, or pseudo-differential. *Figure 1* shows the three modes using the 4-channel MUX ADC0844. The eight inputs of the ADC0848 can also be configured in any of the three modes. In the differential mode, the ADC0844 channel inputs are grouped in pairs, CH1 with CH2 and CH3 with CH4. The polarity assignment of each channel in the pair is interchangeable. The single-ended mode has CH1-CH4 assigned as the positive input with the negative input being the analog ground (AGND) of the device. Finally, in the pseudo-differential mode CH1-CH3 are positive inputs referenced to CH4 which is now a pseudo-ground. This pseudo-ground input can be set to any potential within the input common-mode range of the converter. The analog signal conditioning required in transducer-based data acquisition systems is significantly simplified with this type of input flexibility. One converter package can now handle ground referenced inputs and true differential inputs as well as signals with some arbitrary reference voltage.

The analog input voltages for each channel can range from 50 mV below ground to 50 mV above V_{CC} (typically 5V) without degrading conversion accuracy.

TABLE 1. ADC0844 MUX ADDRESSING

MUX Address				CS	WR	RD	Channel#					MUX Mode
MA3	MA2	MA1	MA0				CH1	CH2	CH3	CH4	AGND	
X	L	L	L	L		H	+	-				Differential
X	L	L	H	L	\bar{L}	H	-	+				
X	L	H	L	L		H			+	-		
X	L	H	H	L		H			-	+		
L	H	L	L	L		H	+				-	Single-Ended
L	H	L	H	L	\bar{L}	H		+			-	
L	H	H	L	L		H			+		-	
L	H	H	H	L		H				+	-	
H	H	L	L	L		H	+				-	Pseudo-Differential
H	H	L	H	L	\bar{L}	H		+			-	
H	H	H	L	L		H			+		-	
X	X	X	X	L	\bar{L}	L	Previous Channel Configuration					

X=don't care

Applications Information (Continued)

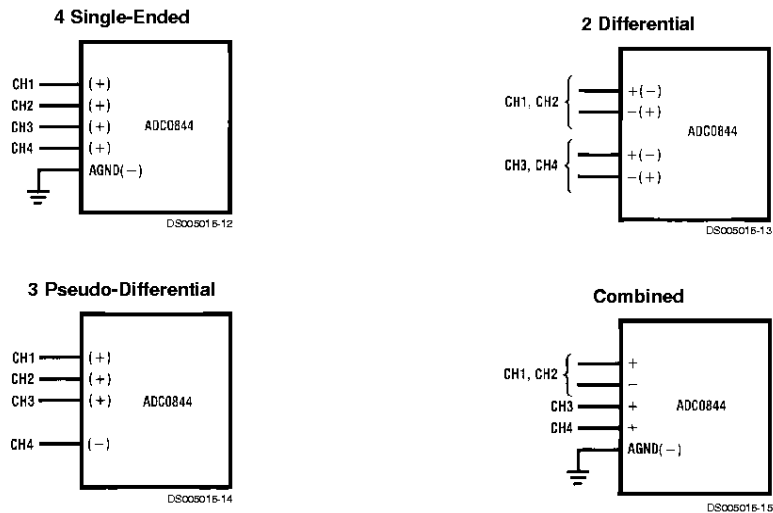

FIGURE 1. Analog Input Multiplexer Options

2.0 REFERENCE CONSIDERATIONS

The voltage applied to the reference input of these converters defines the voltage span of the analog input (the difference between $V_{IN(MAX)}$ and $V_{IN(MIN)}$) over which the 256 possible output codes apply. The devices can be used in either ratiometric applications or in systems requiring absolute accuracy. The reference pin must be connected to a voltage source capable of driving the minimum reference input resistance of 1.1 k Ω . This pin is the top of a resistor divider string used for the successive approximation conversion.

In a ratiometric system (Figure 2a), the analog input voltage is proportional to the voltage used for the A/D reference. This voltage is typically the system power supply, so the V_{REF} pin can be tied to V_{CC} . This technique relaxes the stability requirements of the system reference as the analog input and A/D reference move together maintaining the same output code for a given input condition.

For absolute accuracy (Figure 2b), where the analog input varies between very specific voltage limits, the reference pin can be biased with a time and temperature stable voltage source. The LM385 and LM336 reference diodes are good low current devices to use with these converters.

The maximum value of the reference is limited to the V_{CC} supply voltage. The minimum value, however, can be quite small (see Typical Performance Characteristics) to allow direct conversions of transducer outputs providing less than a 5V output span. Particular care must be taken with regard to noise pickup, circuit layout and system error voltage sources when operating with a reduced span due to the increased sensitivity of the converter (1 LSB equals $V_{REF}/256$).

3.0 THE ANALOG INPUTS

3.1 Analog Differential Voltage Inputs and Common-Mode Rejection

The differential input of these converters actually reduces the effects of common-mode input noise, a signal common to both selected "+" and "-" inputs for a conversion (60 Hz is

most typical). The time interval between sampling the "+" input and then the "-" inputs is $\frac{1}{2}$ of a clock period. The change in the common-mode voltage during this short time interval can cause conversion errors. For a sinusoidal common-mode signal this error is:

$$V_{ERROR(MAX)} = V_{peak} (2\pi f_{CM}) \times 0.5 \times \left(\frac{t_C}{8}\right)$$

DS005016-36

where f_{CM} is the frequency of the common-mode signal, V_{peak} is its peak voltage value and t_C is the conversion time. For a 60 Hz common-mode signal to generate a $\frac{1}{4}$ LSB error (≈ 5 mV) with the converter running at 40 μ S, its peak value would have to be 5.43V. This large a common-mode signal is much greater than that generally found in a well designed data acquisition system.

Applications Information (Continued)

TABLE 2. ADC0848 MUX Addressing

MUX Address					CS	WR	RD	Channel								MUX Mode	
MA4	MA3	MA2	MA1	MA0				CH1	CH2	CH3	CH4	CH5	CH6	CH7	CH8		AGND
X	L	L	L	L	L		H	+	-								Differential
X	L	L	L	H	L		H	-	+								
X	L	L	H	L	L		H			+	-						
X	L	L	H	H	L	⌋	H			-	+						
X	L	H	L	L	L		H					+	-				
X	L	H	L	H	L		H					-	+				
X	L	H	H	L	L		H							+	-		
X	L	H	H	H	L		H							-	+		
L	H	L	L	L	L		H	+								-	Single-Ended
L	H	L	L	H	L		H		+							-	
L	H	L	H	L	L		H			+						-	
L	H	L	H	H	L	⌋	H				+					-	
L	H	H	L	L	L		H					+				-	
L	H	H	L	H	L		H						+			-	
L	H	H	H	L	L		H							+		-	
L	H	H	H	H	L		H								+	-	
H	H	L	L	L	L		H	+								-	Pseudo-Differential
H	H	L	L	H	L		H		+							-	
H	H	L	H	L	L		H			+						-	
H	H	L	H	H	L	⌋	H				+					-	
H	H	H	L	L	L		H					+				-	
H	H	H	L	H	L		H						+			-	
H	H	H	H	L	L		H							+		-	
X	X	X	X	X	L	⌋	L	Previous Channel Configuration									

3.2 Input Current

Due to the sampling nature of the analog inputs, short duration spikes of current enter the "+" input and exit the "-" input at the clock edges during the actual conversion. These currents decay rapidly and do not cause errors as the internal comparator is strobed at the end of a clock period. Bypass capacitors at the inputs will average these currents and cause an effective DC current to flow through the output resistance of the analog signal source. Bypass capacitors should not be used if the source resistance is greater than 1 kΩ.

3.3 Input Source Resistance

The limitation of the input source resistance due to the DC leakage currents of the input multiplexer is important. A worst-case leakage current of ± 1 μA over temperature will create a 1 mV input error with a 1 kΩ source resistance. An op amp RC active low pass filter can provide both impedance buffering and noise filtering should a high impedance signal source be required.

4.0 OPTIONAL ADJUSTMENTS

4.1 Zero Error

The zero of the A/D does not require adjustment. If the minimum analog input voltage value, $V_{IN(MIN)}$, is not ground, a zero offset can be done. The converter can be made to out-

put 0000 0000 digital code for this minimum input voltage by biasing any $V_{IN} (-)$ input at this $V_{IN(MIN)}$ value. This is useful for either differential or pseudo-differential modes of input channel configuration.

The zero error of the A/D converter relates to the location of the first riser of the transfer function and can be measured by grounding the V^- input and applying a small magnitude positive voltage to the V^+ input. Zero error is the difference between actual DC input voltage which is necessary to just cause an output digital code transition from 0000 0000 to 0000 0001 and the ideal ½ LSB value (½ LSB=9.8 mV for $V_{REF}=5.000 V_{DC}$).

4.2 Full-Scale

The full-scale adjustment can be made by applying a differential input voltage which is 1 ½ LSB down from the desired analog full-scale voltage range and then adjusting the magnitude of the V_{REF} input for a digital output code changing from 1111 1110 to 1111 1111.

4.3 Adjusting for an Arbitrary Analog Input Voltage Range

If the analog zero voltage of the A/D is shifted away from ground (for example, to accommodate an analog input signal which does not go to ground), this new zero reference should be properly adjusted first. A $V_{IN} (+)$ voltage which equals this desired zero reference plus ½ LSB (where the

Applications Information (Continued)

LSB is calculated for the desired analog span, 1 LSB = analog span/256) is applied to selected "+" input and the zero

reference voltage at the corresponding "-" input should then be adjusted to just obtain the 00_{HEX} to 01_{HEX} code transition.

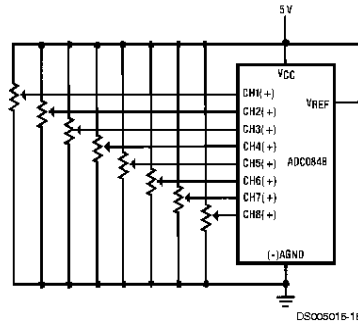

a) Ratiometric

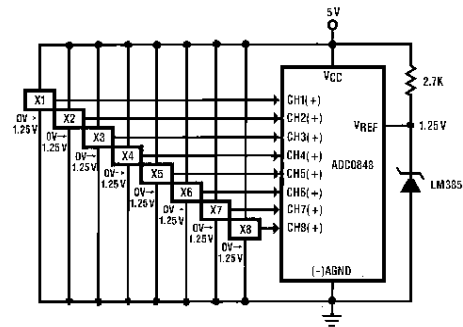

b) Absolute with a Reduced Span

FIGURE 2. Referencing Examples

The full-scale adjustment should be made [with the proper $V_{IN(-)}$ voltage applied] by forcing a voltage to the $V_{IN(+)}$ input which is given by:

$$V_{IN(+)} fs\ adj = V_{MAX} - 1.5 \left[\frac{V_{MAX} - V_{MIN}}{256} \right]$$

where V_{MAX} = the high end of the analog input range and V_{MIN} = the low end (the offset zero) of the analog range. (Both are ground referenced.)

The V_{REF} (or V_{CC}) voltage is then adjusted to provide a code change from FE_{HEX} to FF_{HEX}. This completes the adjustment procedure.

For an example see the Zero-Shift and Span Adjust circuit below.

Zero-Shift and Span Adjust ($2V \leq V_{IN} \leq 5V$)

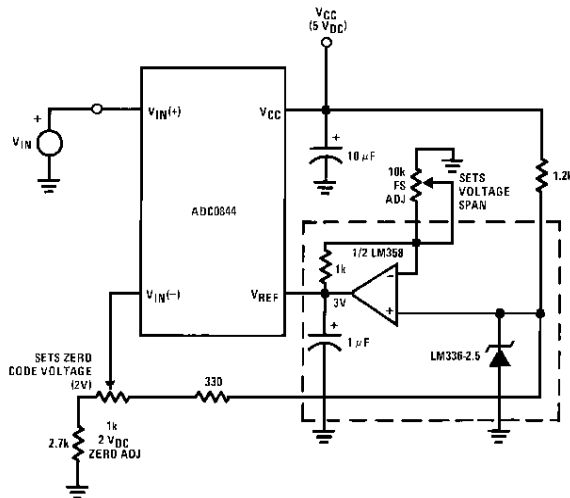

DS00S015-15

Applications Information (Continued)

Differential Voltage Input 9-Bit A/D

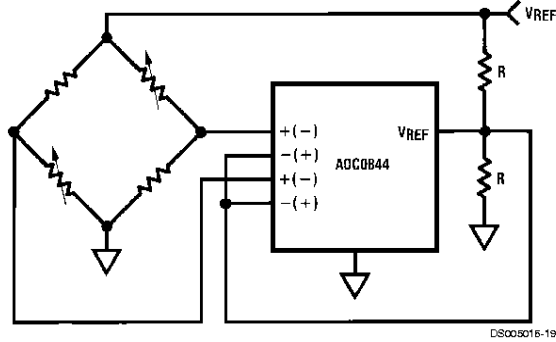

Span Adjust ($0V \leq V_{IN} \leq 3V$)

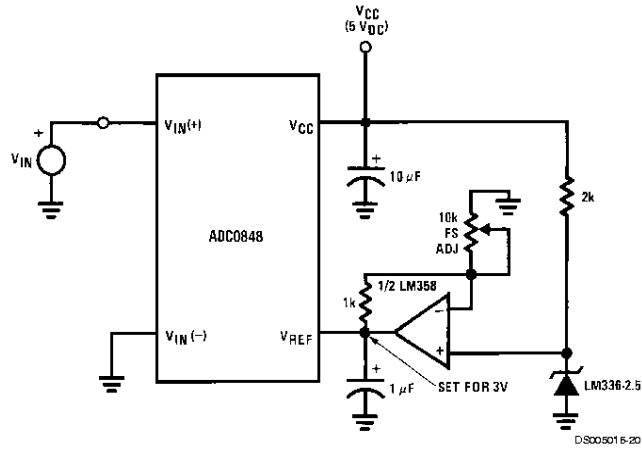

Protecting the Input

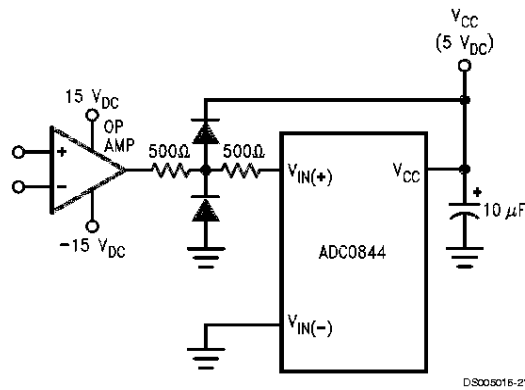

Diodes are 1N914

Applications Information (Continued)

High Accuracy Comparators

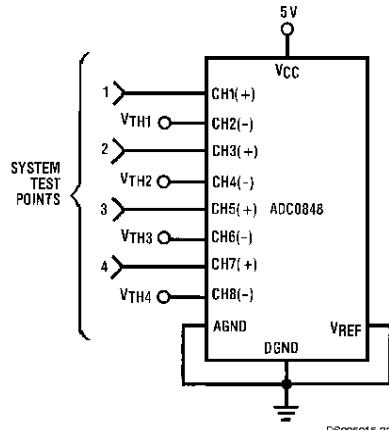

DS005016-22

DO=all 1s if $V_{IN(+)} > V_{IN(-)}$
 DO=all 0s if $V_{IN(+)} < V_{IN(-)}$

Operating with Automotive Ratiometric Transducers

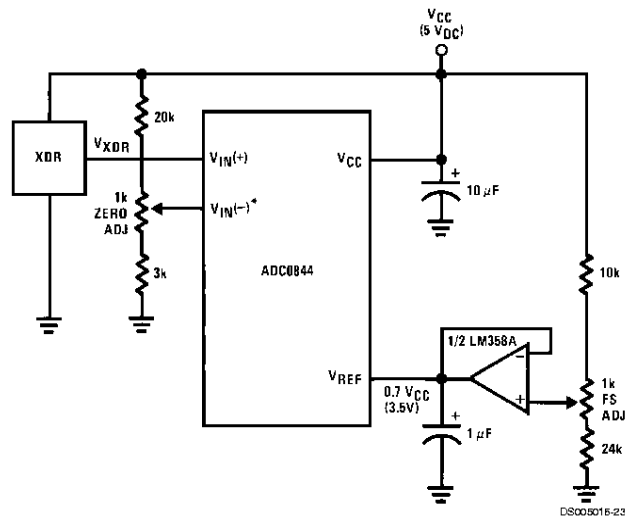

DS005016-23

* $V_{IN(-)} = 0.15 V_{CC}$
 15% of $V_{CC} \leq V_{XDR} \leq 85\%$ of V_{CC}

Applications Information (Continued)

A Stand Alone Circuit

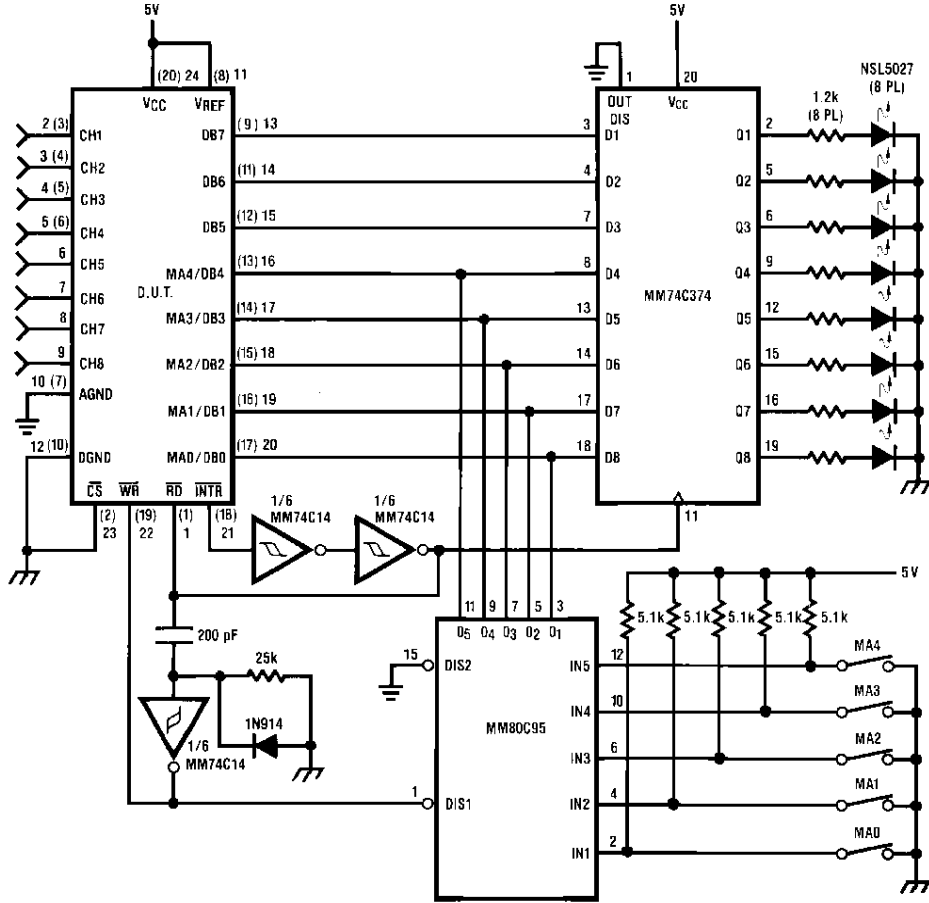

DS00S015-25

Note: DUT pin numbers in parentheses are for ADC0844, others are for ADC0848.

Start a Conversion without Updating the Channel Configuration

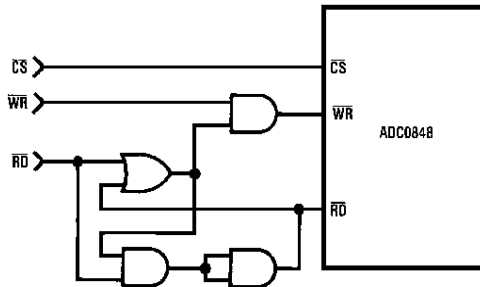

DS00S015-25

$\overline{CS} \cdot \overline{WR}$ will update the channel configuration and start a conversion.
 $\overline{CS} \cdot \overline{RD}$ will read the conversion data and start a new conversion without updating the channel configuration.
 Waiting for the end of this conversion is not necessary. A $\overline{CS} \cdot \overline{WR}$ can immediately follow the $\overline{CS} \cdot \overline{RD}$.

Applications Information (Continued)

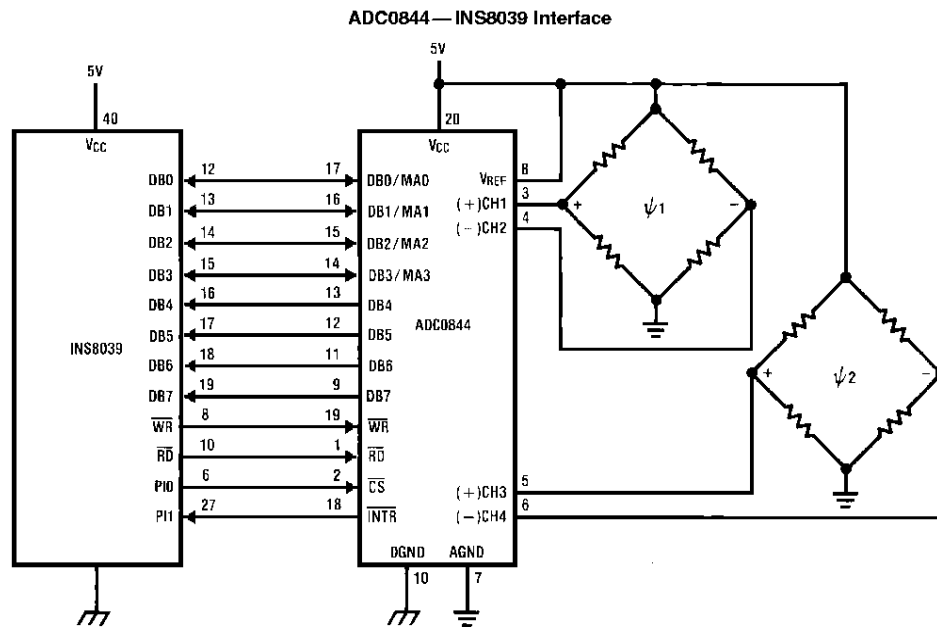

DS008016-27

SAMPLE PROGRAM FOR ADC0844 — INS8039 INTERFACE CONVERTING TWO RATIOMETRIC, DIFFERENTIAL SIGNALS

```

                                ORG      0H
0000  04 10                    JMP      BEGIN      ;START PROGRAM AT ADDR 10
                                ORG      10H          ;MAIN PROGRAM
0010  B9 FF      BEGIN:        MOV      R1,#0FFH    ;LOAD R1 WITH A UNUSED ADDR
                                ;LOCATION
0012  B8 20                    MOV      R0,#20H    ;A/D DATA ADDRESS
0014  89 FF                    ORL      P1,#0FFH    ;SET PORT 1 OUTPUTS HIGH
0016  23 00                    MOV      A,#00H    ;LOAD THE ACC WITH A/D MUX DATA
                                ;CH1 AND CH2 DIFFERENTIAL
0018  14 50                    CALL     CONV      ;CALL THE CONVERSION SUBROUTINE
001A  23 02                    MOV      A,#02H    ;LOAD THE ACC WITH A/D MUX DATA
                                ;CH3 AND CH4 DIFFERENTIAL
001C  18                      INC      R0        ;INCREMENT THE A/D DATA ADDRESS
001D  14 50                    CALL     CONV      ;CALL THE CONVERSION SUBROUTINE

                                ;CONTINUE MAIN PROGRAM

                                ;CONVERSION SUBROUTINE
                                ;ENTRY:ACC — A/D MUX DATA
                                ;EXIT: ACC — CONVERTED DATA

                                ORG      50H
0050  99 FE      CONV:        ANL      P1,#0FEH    ;CHIP SELECT THE A/D
0052  91          MOVX      @R1,A        ;LOAD A/D MUX & START CONVERSION
0053  09      LOOP:        IN       A,P1        ;INPUT INTR STATE

```

Applications Information (Continued)

SAMPLE PROGRAM FOR ADC0844 — INS8039 INTERFACE CONVERTING TWO RATIO-METRIC, DIFFERENTIAL SIGNALS (Continued)

```

0054 32 53          JB1      LOOP          ;IF INTR = 1 GOTO LOOP
0056 81            MOVX     A,@R1        ;IF INTR = 0 INPUT A/D DATA
0057 89 01         ORL     P1,&01H      ;CLEAR THE A/D CHIP SELECT
0059 A0            MOV     @R0,A        ;STORE THE A/D DATA
005A 83            RET                ;RETURN TO MAIN PROGRAM

```

I/O Interface to NSC800

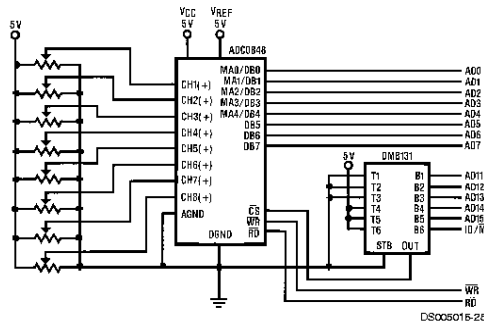

SAMPLE PROGRAM FOR ADC0848 — NSC800 INTERFACE

```

0008          NCONV    EQU    16
000F          DEL      EQU    15          ;DELAY 50 μsec CONVERSION
001F          CS       EQU    1FH        ;THE BOARD ADDRESS
3C00          ADDTA    EQU    003CH      ;START OF RAM FOR A/D
                                                ;DATA

0000' 08 09 0A 0B     MUXDTA:  DB    08H,09H,0AH,0BH      ;MUX DATA
0004' 0C 0D 0E 0F     DB    0CH,0DH,0EH,0FH
0008' 0E 1F          START:  LD     C,CS
000A' 06 16          LD     B,NCONV
000C' 21 0000'       LD     HL,MUXDTA
000F' 11 003C        LD     DE,ADDTA
0012' ED A3          STCONV:  OUTI          ;LOAD A/D'S MUX DATA
                                                ;AND START A CONVERSION
0014' EB            EX     DE,HL          ;HL=RAM ADDRESS FOR THE
                                                ;A/D DATA

0015' 3E 0F          LD     A,DEL
0017' 3D          WAIT:   DEC    A          ;WAIT 50 μsec FOR THE
0018' C2 0013'       JP     NZ,WAIT      ;CONVERSION TO FINISH
001B' ED A2          INI          ;STORE THE A/D'S DATA
                                                ;CONVERTED ALL INPUTS?

001D' EB            EX     DE,HL
001E' C2 000E'       JP     NZ,STCONV     ;IF NOT GOTO STCONV

END

```

Note 14: This routine sequentially programs the MUX data latch in the signal-ended mode. For CH1-CH8 a conversion is started, then a 50 μs wait for the A/D to complete a conversion and the data is stored at address ADDTA for CH1, ADDTA + 1 for CH2, etc.

Applications Information (Continued)

Ordering Information

Temperature Range	Total Unadjusted Error		MUX Channels	Package Outline
	$\pm 1/2$ LSB	± 1 LSB		
0°C to +70°C	ADC0844BCN	ADC0844CCN	4	N20A Molded Dip
	ADC0848BCN	ADC0848CCN	8	N24C Molded Dip
-40°C to +85°C	ADC0844BCJ	ADC0844CCJ	4	J20A Cerdip
	ADC0848BCJ	ADC0848CCJ	8	J24F Cerdip
	ADC0848BCV	ADC0848CCV	8	V28A Molded Chip Carrier

Physical Dimensions inches (millimeters) unless otherwise noted

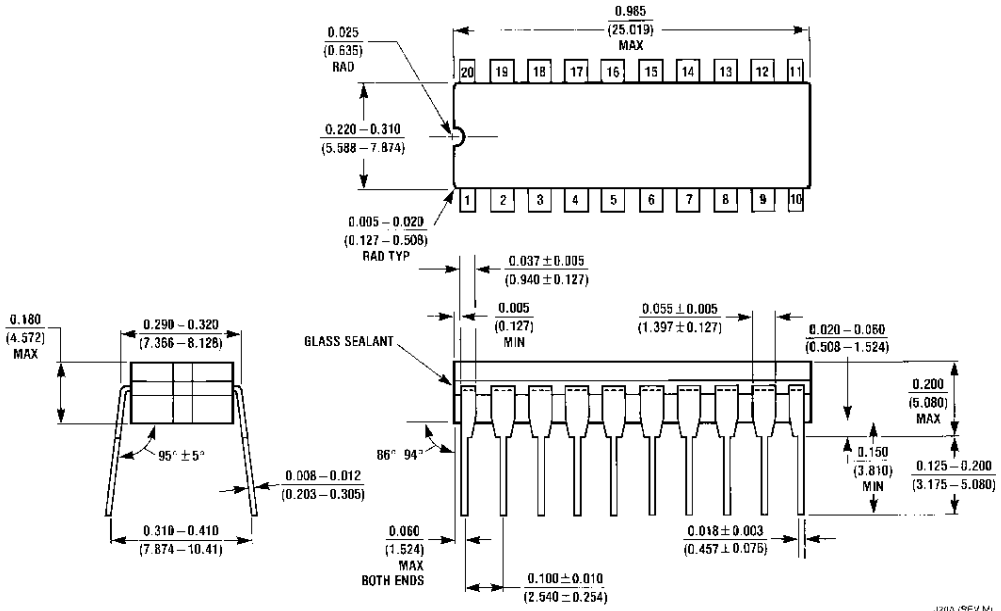

Ceramic Dual-In-Line Package (J)
NS Package Number J20A

J20A (REV M)

Physical Dimensions inches (millimeters) unless otherwise noted (Continued)

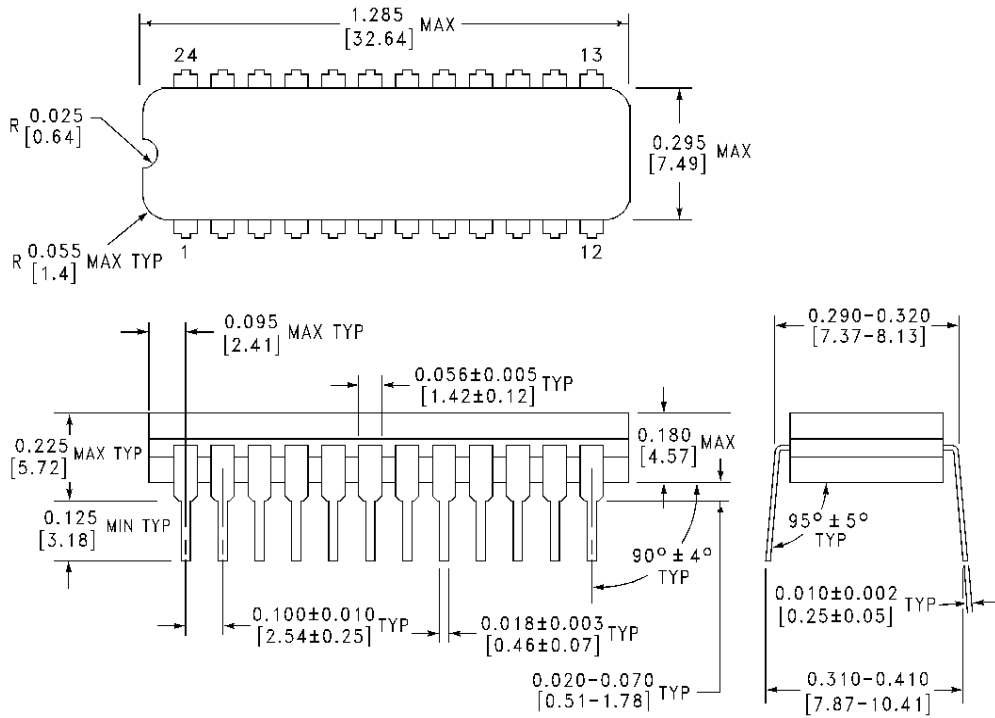

J24F (REV. H)

Cavity Dual-In-Line Package (J)
NS Package Number J24F

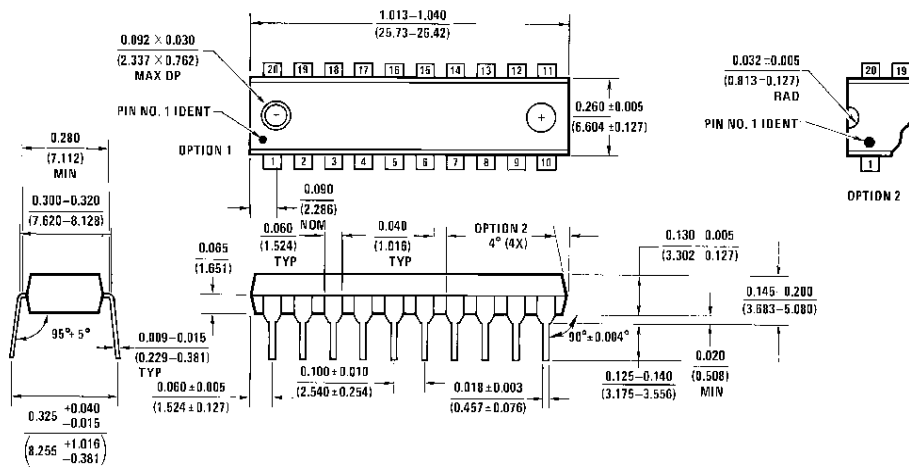

N20A (REV. G)

Molded Dual-In-Line Package (N)
NS Package Number N20A

Physical Dimensions inches (millimeters) unless otherwise noted (Continued)

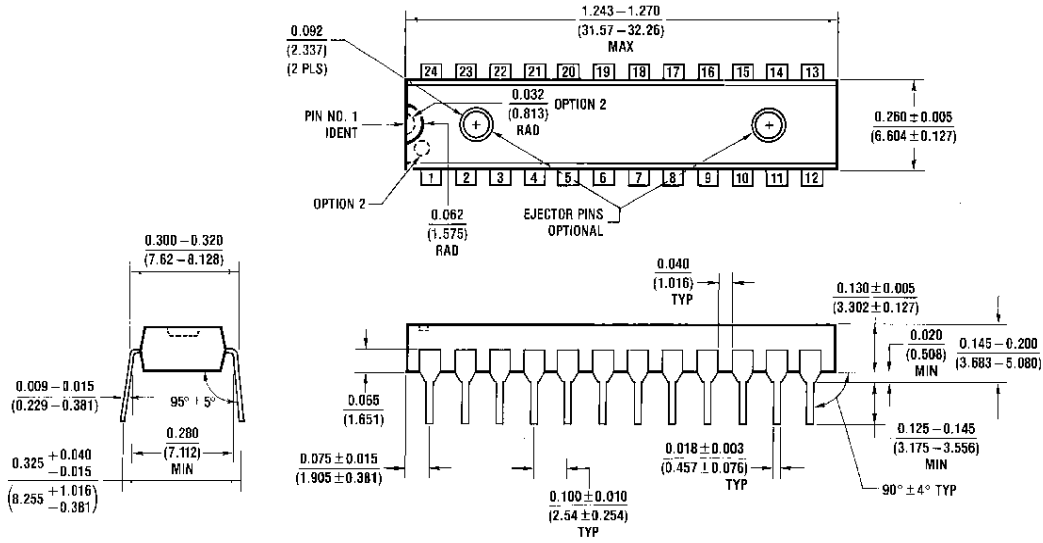

N24C (REV F)

Molded Dual-In-Line Package (N)
NS Package Number N24C

Physical Dimensions inches (millimeters) unless otherwise noted (Continued)

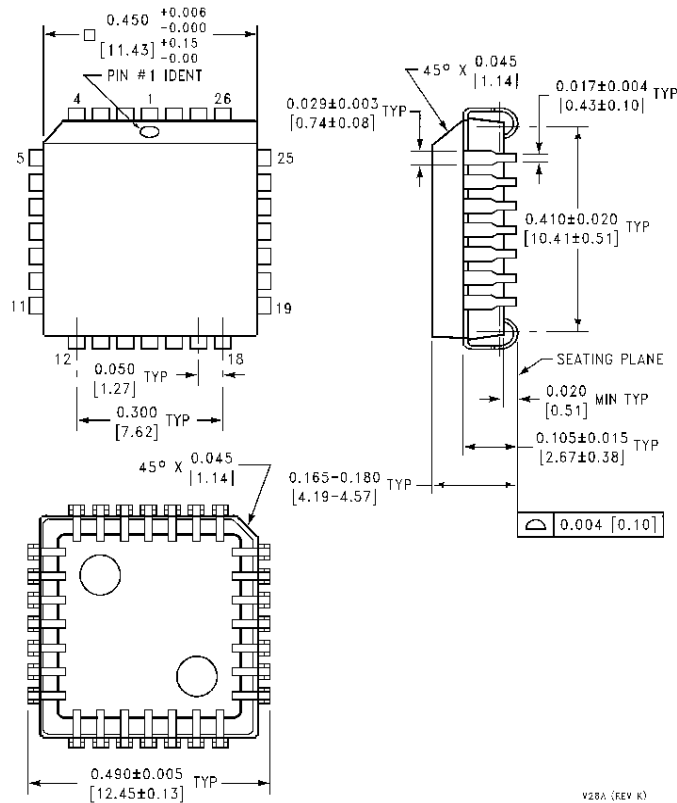

**Molded Chip Carrier Package (V)
NS Package Number V28A**

V28A (REV K)

LIFE SUPPORT POLICY

NATIONAL'S PRODUCTS ARE NOT AUTHORIZED FOR USE AS CRITICAL COMPONENTS IN LIFE SUPPORT DEVICES OR SYSTEMS WITHOUT THE EXPRESS WRITTEN APPROVAL OF THE PRESIDENT OF NATIONAL SEMICONDUCTOR CORPORATION. As used herein:

1. Life support devices or systems are devices or systems which, (a) are intended for surgical implant into the body, or (b) support or sustain life, and whose failure to perform when properly used in accordance with instructions for use provided in the labeling, can be reasonably expected to result in a significant injury to the user.
2. A critical component is any component of a life support device or system whose failure to perform can be reasonably expected to cause the failure of the life support device or system, or to affect its safety or effectiveness.



National Semiconductor Corporation
Americas
Tel: 1-800-272-9959
Fax: 1-800-737-7018
Email: support@nsc.com

National Semiconductor Europe
Fax: +49 (0) 1 80-530 85 86
Email: europe.support@nsc.com
Deutsch Tel: +49 (0) 1 80-530 85 85
English Tel: +49 (0) 1 80-532 78 32
Français Tel: +49 (0) 1 80-532 93 58
Italiano Tel: +49 (0) 1 80-534 16 80

National Semiconductor Asia Pacific Customer Response Group
Tel: 65-2544466
Fax: 65-2504466
Email: sea.support@nsc.com

National Semiconductor Japan Ltd.
Tel: 81-3-5639-7560
Fax: 81-3-5639-7507

www.national.com