

National Semiconductor is now part of
Texas Instruments.

Search <http://www.ti.com/> for the latest technical
information and details on our current products and services.

LM723/LM723C Voltage Regulator

General Description

The LM723/LM723C is a voltage regulator designed primarily for series regulator applications. By itself, it will supply output currents up to 150 mA; but external transistors can be added to provide any desired load current. The circuit features extremely low standby current drain, and provision is made for either linear or foldback current limiting.

The LM723/LM723C is also useful in a wide range of other applications such as a shunt regulator, a current regulator or a temperature controller.

The LM723C is identical to the LM723 except that the LM723C has its performance guaranteed over a 0°C to +70°C temperature range, instead of -55°C to +125°C.

Features

- 150 mA output current without external pass transistor
- Output currents in excess of 10A possible by adding external transistors
- Input voltage 40V max
- Output voltage adjustable from 2V to 37V
- Can be used as either a linear or a switching regulator

Connection Diagrams

Dual-In-Line Package

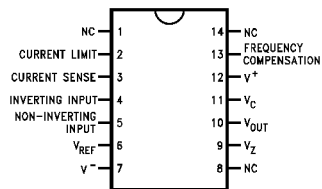

DS008563-2

Top View

Order Number LM723J/883 or LM723CN
See NS Package J14A or N14A

Metal Can Package

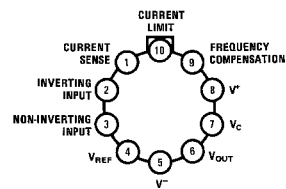

DS008563-3

Note: Pin 5 connected to case.

Top View

Order Number LM723H, LM723H/883 or LM723CH
See NS Package H10C

Connection Diagrams (Continued)

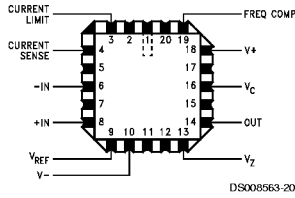

Top View
Order Number LM723E/883
See NS Package E20A

Equivalent Circuit*

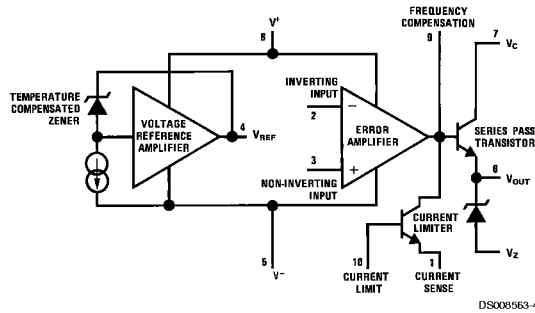

*Pin numbers refer to metal can package.

Typical Application

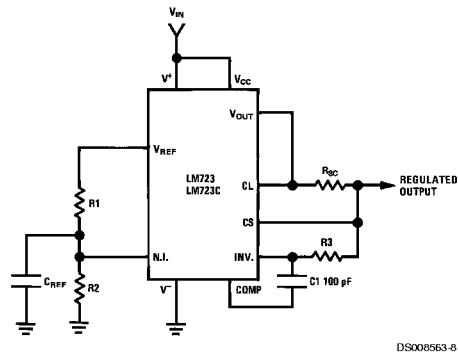

Note: $R3 = \frac{R1 R2}{R1 + R2}$

for minimum temperature drift.

Typical Performance

Regulated Output Voltage	5V
Line Regulation ($\Delta V_{IN} = 3V$)	0.5mV
Load Regulation ($\Delta I_L = 50 \text{ mA}$)	1.5mV

FIGURE 1. Basic Low Voltage Regulator
($V_{OUT} = 2$ to 7 Volts)

Absolute Maximum Ratings (Note 1)

If Military/Aerospace specified devices are required, please contact the National Semiconductor Sales Office/Distributors for availability and specifications.

Pulse Voltage from V^+ to V^- (50 ms)	50V
Continuous Voltage from V^+ to V^-	40V
Input-Output Voltage Differential	40V
Maximum Amplifier Input Voltage (Either Input)	8.5V
Maximum Amplifier Input Voltage (Differential)	5V
Current from V_Z	25 mA
Current from V_{REF}	15 mA
Internal Power Dissipation Metal Can (Note 2)	800 mW

Cavity DIP (Note 2)	900 mW
Molded DIP (Note 2)	660 mW
Operating Temperature Range	
LM723	-55°C to +150°C
LM723C	0°C to +70°C
Storage Temperature Range	
Metal Can	-65°C to +150°C
Molded DIP	-55°C to +150°C
Lead Temperature (Soldering, 4 sec. max.)	
Hermetic Package	300°C
Plastic Package	260°C
ESD Tolerance (Human body model, 1.5 kΩ in series with 100 pF)	1200V

Electrical Characteristics (Note 3) (Note 10)

Parameter	Conditions	LM723			LM723C			Units
		Min	Typ	Max	Min	Typ	Max	
Line Regulation	$V_{IN} = 12V$ to $V_{IN} = 15V$		0.01	0.1		0.01	0.1	% V_{OUT}
	$-55^\circ C \leq T_A \leq +125^\circ C$			0.3				% V_{OUT}
	$0^\circ C \leq T_A \leq +70^\circ C$						0.3	% V_{OUT}
	$V_{IN} = 12V$ to $V_{IN} = 40V$		0.02	0.2		0.1	0.5	% V_{OUT}
Load Regulation	$I_L = 1$ mA to $I_L = 50$ mA		0.03	0.15		0.03	0.2	% V_{OUT}
	$-55^\circ C \leq T_A \leq +125^\circ C$			0.6				% V_{OUT}
	$0^\circ C \leq T_A \leq +70^\circ C$						0.6	% V_{OUT}
Ripple Rejection	$f = 50$ Hz to 10 kHz, $C_{REF} = 0$		74			74		dB
	$f = 50$ Hz to 10 kHz, $C_{REF} = 5 \mu F$		86			86		dB
Average Temperature Coefficient of Output Voltage (Note 8)	$-55^\circ C \leq T_A \leq +125^\circ C$		0.002	0.015				%/°C
	$0^\circ C \leq T_A \leq +70^\circ C$					0.003	0.015	%/°C
Short Circuit Current Limit	$R_{SC} = 10\Omega$, $V_{OUT} = 0$		65			65		mA
Reference Voltage		6.95	7.15	7.35	6.80	7.15	7.50	V
Output Noise Voltage	$BW = 100$ Hz to 10 kHz, $C_{REF} = 0$		86			86		μV_{rms}
	$BW = 100$ Hz to 10 kHz, $C_{REF} = 5 \mu F$		2.5			2.5		μV_{rms}
Long Term Stability			0.05			0.05		%/1000 hrs
Standby Current Drain	$I_L = 0$, $V_{IN} = 30V$		1.7	3.5		1.7	4.0	mA
Input Voltage Range		9.5		40	9.5		40	V
Output Voltage Range		2.0		37	2.0		37	V
Input-Output Voltage Differential		3.0		38	3.0		38	V
θ_{JA}	Molded DIP					105		°C/W
θ_{JA}	Cavity DIP		150					°C/W
θ_{JA}	H10C Board Mount in Still Air		165			165		°C/W
θ_{JA}	H10C Board Mount in 400 LF/Min Air Flow		66			66		°C/W
θ_{JC}						22		°C/W

Note 1: "Absolute Maximum Ratings" indicate limits beyond which damage to the device may occur. Operating Ratings indicate conditions for which the device is functional, but do not guarantee specific performance limits.

Note 2: See derating curves for maximum power rating above 25°C.

Note 3: Unless otherwise specified, $T_A = 25^\circ C$, $V_{IN} = V^+ = V_C = 12V$, $V^- = 0$, $V_{OUT} = 5V$, $I_L = 1$ mA, $R_{SC} = 0$, $C_1 = 100$ pF, $C_{REF} = 0$ and divider impedance as seen by error amplifier ≤ 10 kΩ connected as shown in Figure 1. Line and load regulation specifications are given for the condition of constant chip temperature. Temperature drifts must be taken into account separately for high dissipation conditions.

Note 4: L_1 is 40 turns of No. 20 enameled copper wire wound on Ferroxcube P36/22-3B7 pot core or equivalent with 0.009 in. air gap.

Note 5: Figures in parentheses may be used if R1/R2 divider is placed on opposite input of error amp.

Note 6: Replace R1/R2 in figures with divider shown in Figure 13.

Note 7: V^+ and V_{CC} must be connected to a +3V or greater supply.

Note 8: For metal can applications where V_Z is required, an external 6.2V zener diode should be connected in series with V_{OUT} .

Electrical Characteristics (Note 3) (Note 10) (Continued)

Note 9: Guaranteed by correlation to other tests.

Note 10: A military RETS specification is available on request. At the time of printing, the LM723 RETS specification complied with the Min and Max limits in this table. The LM723E, H, and J may also be procured as a Standard Military Drawing.

Typical Performance Characteristics

Load Regulation Characteristics with Current Limiting

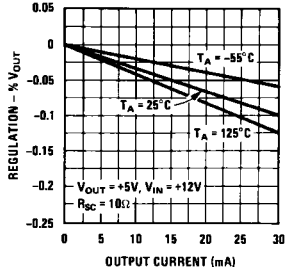

Load Regulation Characteristics with Current Limiting

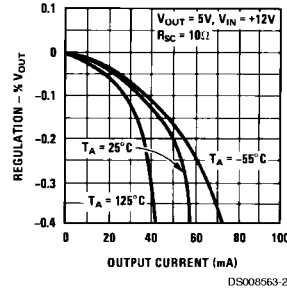

Load & Line Regulation vs Input-Output Voltage Differential

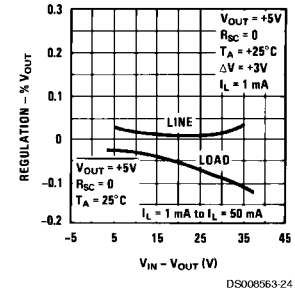

Current Limiting Characteristics

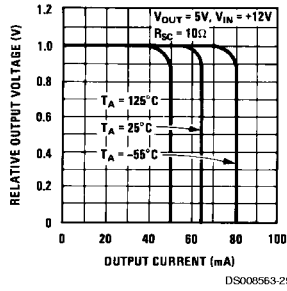

Current Limiting Characteristics vs Junction Temperature

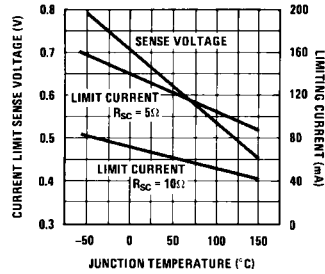

Standby Current Drain vs Input Voltage

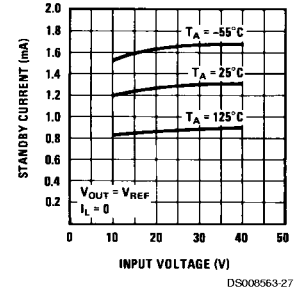

Line Transient Response

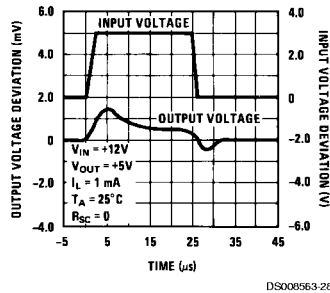

Load Transient Response

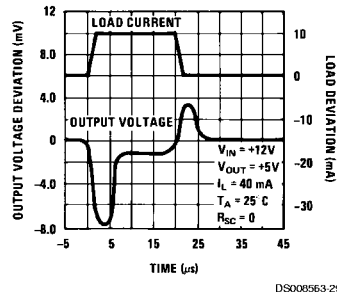

Output Impedance vs Frequency

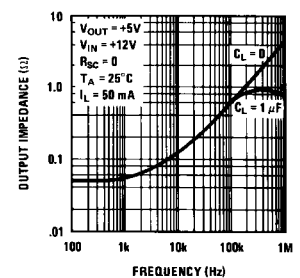

Maximum Power Ratings

Noise vs Filter Capacitor
(C_{REF} in Circuit of Figure 1)
(Bandwidth 100 Hz to 10 kHz)

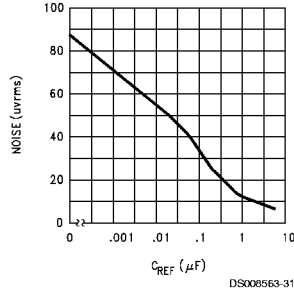

LM723
Power Dissipation vs
Ambient Temperature

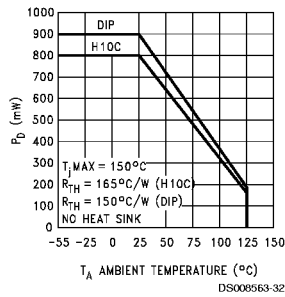

LM723C
Power Dissipation vs
Ambient Temperature

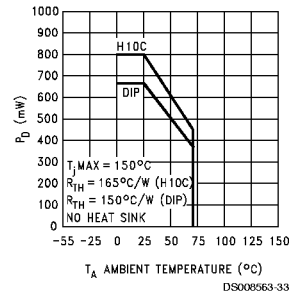

TABLE 1. Resistor Values (kΩ) for Standard Output Voltage

Positive Output Voltage	Applicable Figures (Note 5)	Fixed Output ±5%		Output Adjustable ±10% (Note 6)			Negative Output Voltage	Applicable Figures	Fixed Output ±5%		5% Output Adjustable ±10%		
		R1	R2	R1	P1	R2			R1	R2	R1	P1	R2
+3.0	1, 5, 6, 9, 12 (4)	4.12	3.01	1.8	0.5	1.2	+100	7	3.57	102	2.2	10	91
+3.6	1, 5, 6, 9, 12 (4)	3.57	3.65	1.5	0.5	1.5	+250	7	3.57	255	2.2	10	240
+5.0	1, 5, 6, 9, 12 (4)	2.15	4.99	0.75	0.5	2.2	-6 (Note 7)	3, (10)	3.57	2.43	1.2	0.5	0.75
+6.0	1, 5, 6, 9, 12 (4)	1.15	6.04	0.5	0.5	2.7	-9	3, 10	3.48	5.36	1.2	0.5	2.0
+9.0	2, 4, (5, 6, 9, 12)	1.87	7.15	0.75	1.0	2.7	-12	3, 10	3.57	8.45	1.2	0.5	3.3
+12	2, 4, (5, 6, 9, 12)	4.87	7.15	2.0	1.0	3.0	-15	3, 10	3.65	11.5	1.2	0.5	4.3
+15	2, 4, (5, 6, 9, 12)	7.87	7.15	3.3	1.0	3.0	-28	3, 10	3.57	24.3	1.2	0.5	10
+28	2, 4, (5, 6, 9, 12)	21.0	7.15	5.6	1.0	2.0	-45	8	3.57	41.2	2.2	10	33
+45	7	3.57	48.7	2.2	10	39	-100	8	3.57	97.6	2.2	10	91
+75	7	3.57	78.7	2.2	10	68	-250	8	3.57	249	2.2	10	240

TABLE 2. Formulae for Intermediate Output Voltages

Outputs from +2 to +7 volts (Figures 1, 4, 5, 6, 9, 12) $V_{OUT} = \left(V_{REF} \times \frac{R_2}{R_1 + R_2} \right)$	Outputs from +4 to +250 volts (Figure 7) $V_{OUT} = \left(\frac{V_{REF}}{2} \times \frac{R_2 - R_1}{R_1} \right); R_3 = R_4$	Current Limiting $I_{LIMIT} = \frac{V_{SENSE}}{R_{SC}}$
Outputs from +7 to +37 volts (Figures 2, 4, 5, 6, 9, 12) $V_{OUT} = \left(V_{REF} \times \frac{R_1 + R_2}{R_2} \right)$	Outputs from -6 to -250 volts (Figures 3, 8, 10) $V_{OUT} = \left(\frac{V_{REF}}{2} \times \frac{R_1 + R_2}{R_1} \right); R_3 = R_4$	Foldback Current Limiting $I_{KNEE} = \left(\frac{V_{OUT} R_3}{R_{SC} R_4} + \frac{V_{SENSE} (R_3 + R_4)}{R_{SC} R_4} \right)$ $I_{SHORT\ CKT} = \left(\frac{V_{SENSE}}{R_{SC}} \times \frac{R_3 + R_4}{R_4} \right)$

Typical Applications

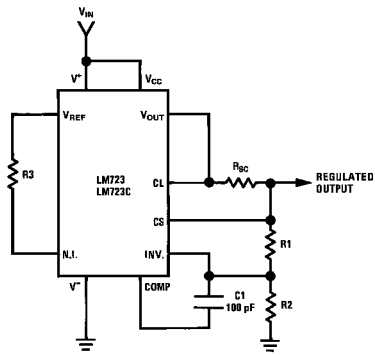

DS008563-9

Note: $R3 = \frac{R1 R2}{R1 + R2}$

for minimum temperature drift.
R3 may be eliminated for minimum component count.

Typical Performance

Regulated Output Voltage	15V
Line Regulation ($\Delta V_{IN} = 3V$)	1.5 mV
Load Regulation ($\Delta I_L = 50 \text{ mA}$)	4.5 mV

FIGURE 2. Basic High Voltage Regulator
($V_{OUT} = 7$ to 37 Volts)

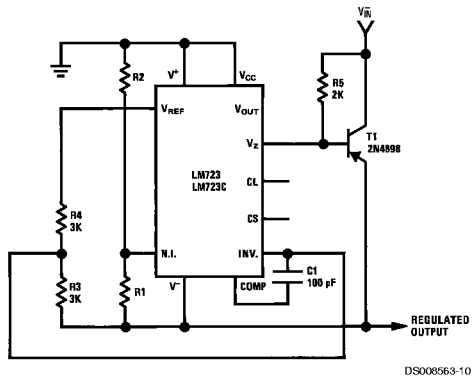

DS008563-10

Typical Performance

Regulated Output Voltage	-15V
Line Regulation ($\Delta V_{IN} = 3V$)	1 mV
Load Regulation ($\Delta I_L = 100 \text{ mA}$)	2 mV

FIGURE 3. Negative Voltage Regulator

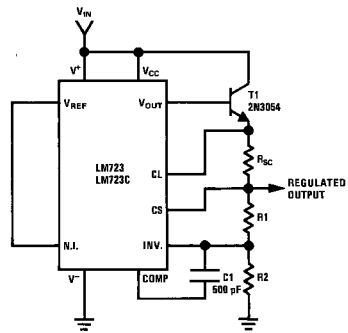

DS008563-11

Typical Performance

Regulated Output Voltage	+15V
Line Regulation ($\Delta V_{IN} = 3V$)	1.5 mV
Load Regulation ($\Delta I_L = 1A$)	15 mV

FIGURE 4. Positive Voltage Regulator
(External NPN Pass Transistor)

Typical Applications (Continued)

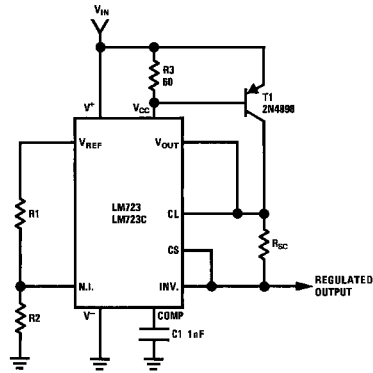

DS008563-12

Typical Performance

Regulated Output Voltage	+5V
Line Regulation ($\Delta V_{IN} = 3V$)	0.5 mV
Load Regulation ($\Delta I_L = 1A$)	5 mV

**FIGURE 5. Positive Voltage Regulator
(External PNP Pass Transistor)**

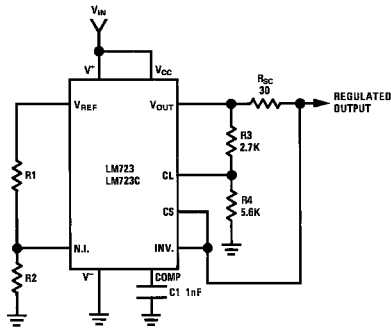

DS008563-13

Typical Performance

Regulated Output Voltage	+5V
Line Regulation ($\Delta V_{IN} = 3V$)	0.5 mV
Load Regulation ($\Delta I_L = 10 \text{ mA}$)	1 mV
Short Circuit Current	20 mA

FIGURE 6. Foldback Current Limiting

Typical Applications (Continued)

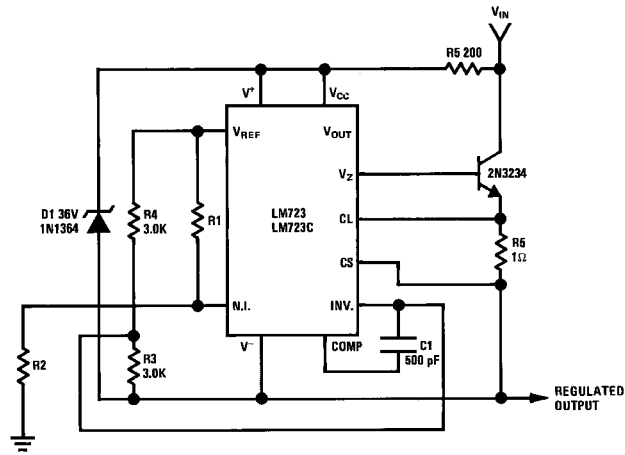

DS008563-14

Typical Performance

Regulated Output Voltage	+50V
Line Regulation ($\Delta V_{IN} = 20V$)	15 mV
Load Regulation ($\Delta I_L = 50 \text{ mA}$)	20 mV

FIGURE 7. Positive Floating Regulator

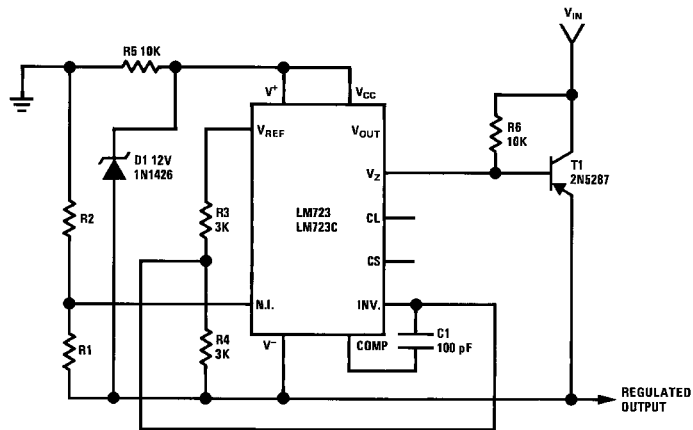

DS008563-15

Typical Performance

Regulated Output Voltage	-100V
Line Regulation ($\Delta V_{IN} = 20V$)	30 mV
Load Regulation ($\Delta I_L = 100 \text{ mA}$)	20 mV

FIGURE 8. Negative Floating Regulator

Typical Applications (Continued)

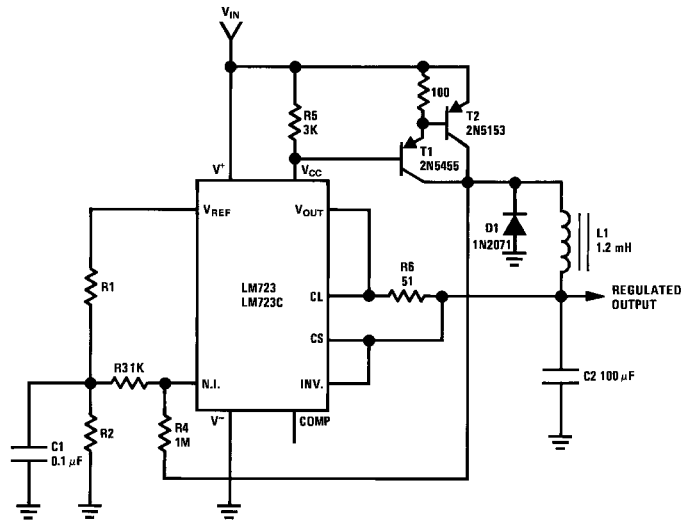

DS008563-16

Typical Performance

Regulated Output Voltage	+5V
Line Regulation ($\Delta V_{IN} = 30V$)	10 mV
Load Regulation ($\Delta I_L = 2A$)	80 mV

FIGURE 9. Positive Switching Regulator

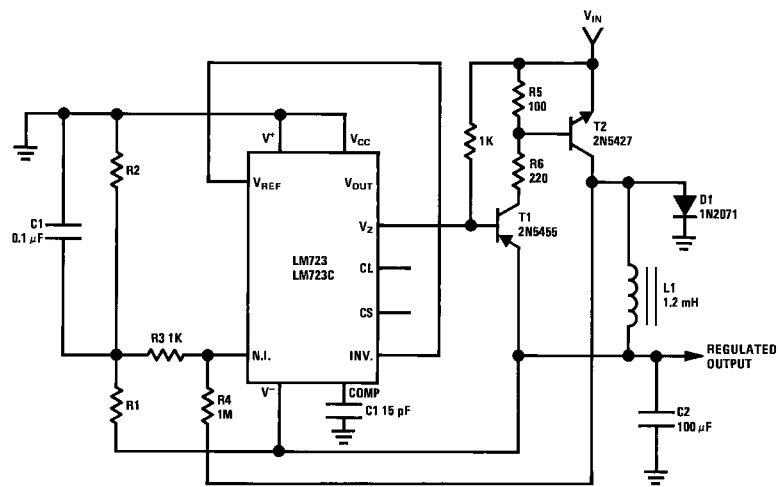

DS008563-17

Typical Performance

Regulated Output Voltage	-15V
Line Regulation ($\Delta V_{IN} = 20V$)	8 mV
Load Regulation ($\Delta I_L = 2A$)	6 mV

FIGURE 10. Negative Switching Regulator

Typical Applications (Continued)

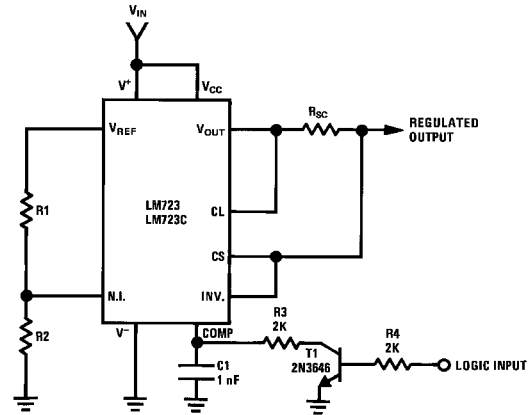

DS000563-18

Note: Current limit transistor may be used for shutdown if current limiting is not required.

Typical Performance

Regulated Output Voltage	+5V
Line Regulation ($\Delta V_{IN} = 3V$)	0.5 mV
Load Regulation ($\Delta I_L = 50 \text{ mA}$)	1.5 mV

FIGURE 11. Remote Shutdown Regulator with Current Limiting

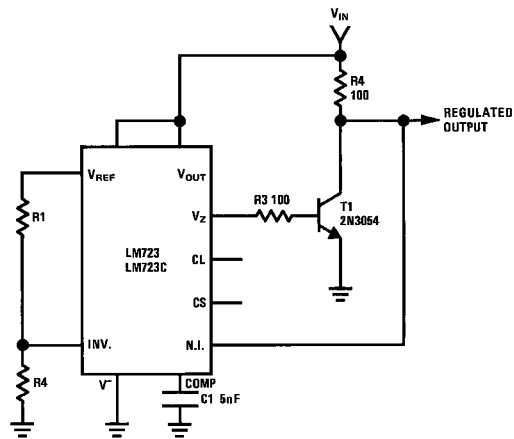

DS000563-19

Regulated Output Voltage	+5V
Line Regulation ($\Delta V_{IN} = 10V$)	0.5 mV
Load Regulation ($\Delta I_L = 100 \text{ mA}$)	1.5 mV

FIGURE 12. Shunt Regulator

Typical Applications (Continued)

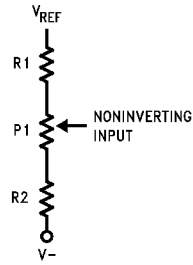

DS000563-21

FIGURE 13. Output Voltage Adjust
(Note 6)

Schematic Diagram

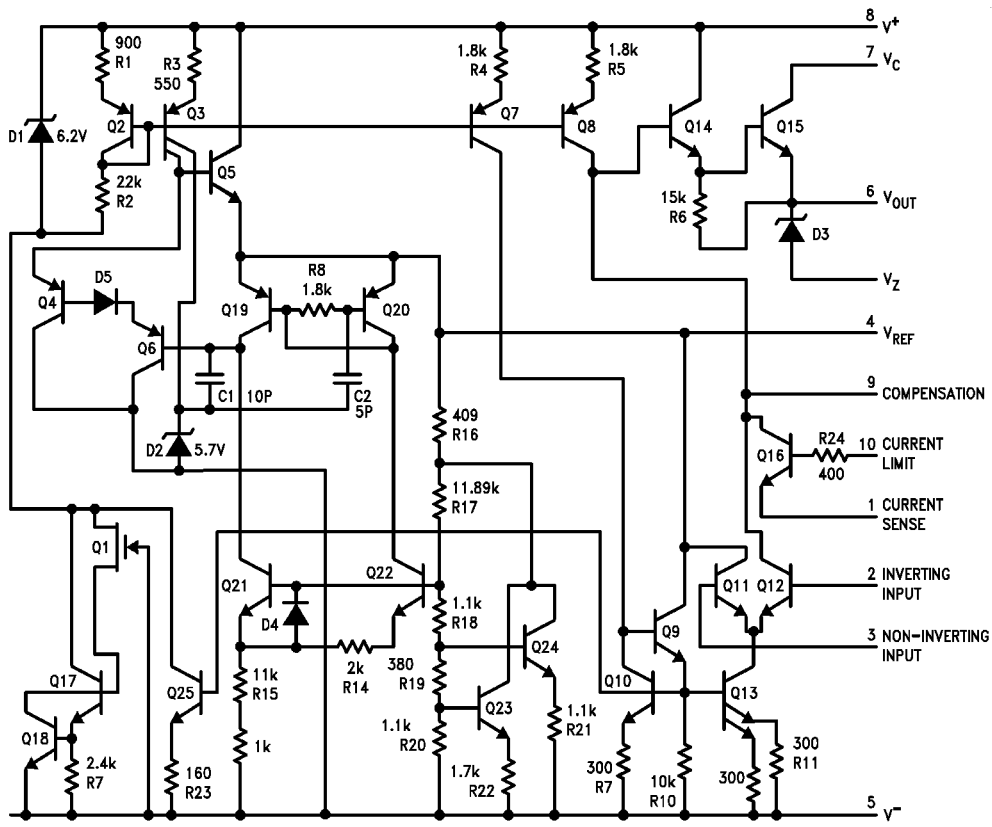

DS000563-1

Physical Dimensions inches (millimeters) unless otherwise noted

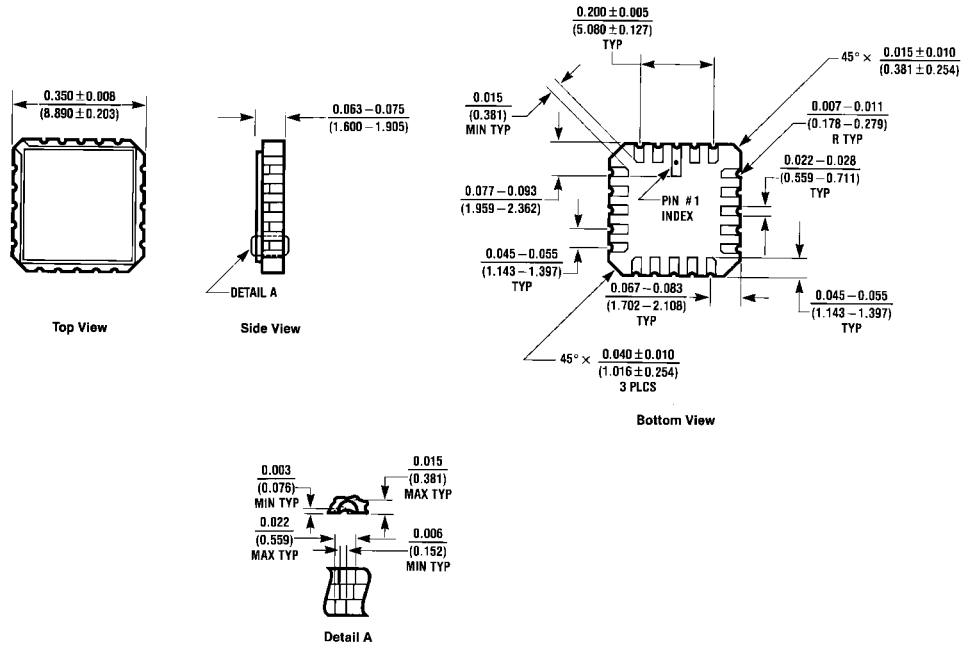

E20A (REV D)

Leadless Chip Carrier Package (E)
Order Number LM723E/883
NS Package E20A

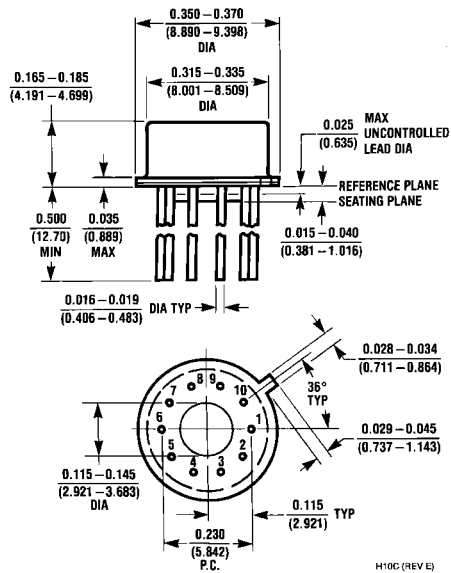

H10C (REV E)

Metal Can Package (H)
Order Number LM723H, LM723H/883 or LM723CH
NS Package H10C

Physical Dimensions inches (millimeters) unless otherwise noted (Continued)

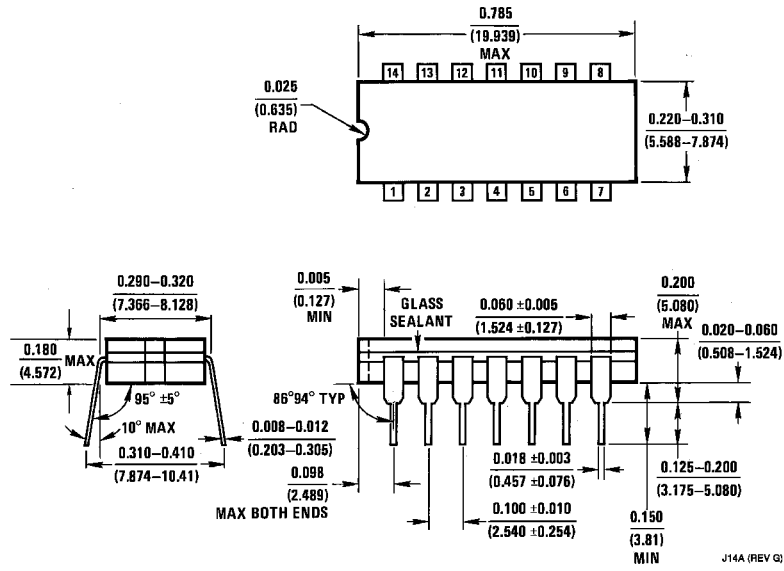

Ceramic Dual-In-Line Package (J)
Order Number LM723J/883
NS Package J14A

J14A (REV G)

Physical Dimensions inches (millimeters) unless otherwise noted (Continued)

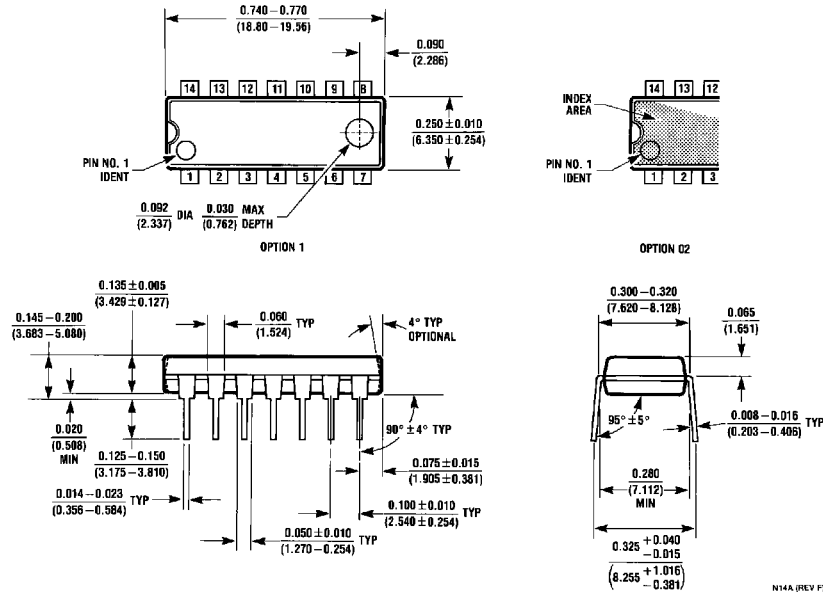

Molded Dual-In-Line Package (N)
Order Number LM723CN
NS Package N14A

LIFE SUPPORT POLICY

NATIONAL'S PRODUCTS ARE NOT AUTHORIZED FOR USE AS CRITICAL COMPONENTS IN LIFE SUPPORT DEVICES OR SYSTEMS WITHOUT THE EXPRESS WRITTEN APPROVAL OF THE PRESIDENT AND GENERAL COUNSEL OF NATIONAL SEMICONDUCTOR CORPORATION. As used herein:

1. Life support devices or systems are devices or systems which, (a) are intended for surgical implant into the body, or (b) support or sustain life, and whose failure to perform when properly used in accordance with instructions for use provided in the labeling, can be reasonably expected to result in a significant injury to the user.
2. A critical component is any component of a life support device or system whose failure to perform can be reasonably expected to cause the failure of the life support device or system, or to affect its safety or effectiveness.



National Semiconductor Corporation
Americas
Tel: 1-800-272-9959
Fax: 1-800-737-7018
Email: support@nsc.com

www.national.com

National Semiconductor Europe
Fax: +49 (0) 1 80-530 85 86
Email: europe.support@nsc.com
Deutsch Tel: +49 (0) 1 80-530 85 85
English Tel: +49 (0) 1 80-532 78 32
Français Tel: +49 (0) 1 80-532 93 58
Italiano Tel: +49 (0) 1 80-534 16 80

National Semiconductor Asia Pacific Customer Response Group
Tel: 65-2544466
Fax: 65-2504466
Email: sea.support@nsc.com

National Semiconductor Japan Ltd.
Tel: 81-3-5639-7560
Fax: 81-3-5639-7507