

High-Speed Quad Monolithic SPST CMOS Analog Switch

Features

- Fast Switching t_{ON} : 55 ns
- Low Charge Injection: 9 pC
- Low $r_{DS(on)}$: 32 Ω
- TTL Compatible
- Low Leakage: 50 pA

Benefits

- Fast Settling Times
- Reduced Switching Glitches
- High Precision

Applications

- High Speed Switching
- Sample/Holds
- Digital Filters
- Op Amp Gain Switching
- Flight Control Systems

Description

The DG271 high speed quad single-pole single-throw analog switch is intended for applications that require low on-resistance, low leakage currents, and fast switching speeds.

Built on Siliconix' proprietary high voltage silicon gate process to achieve superior on/off performance, each switch conducts equally well in both directions when on, and blocks up to the supply voltage when off. An epitaxial layer prevents latchup.

Functional Block Diagram and Pin Configuration

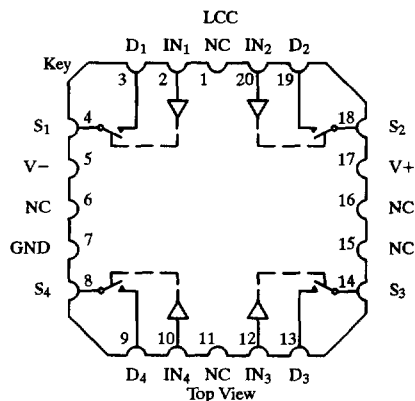
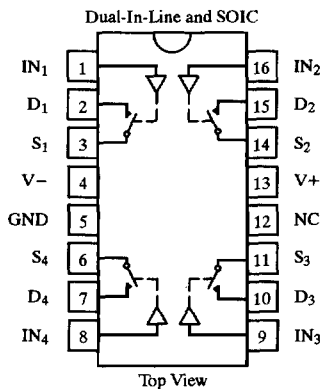

Ordering Information

Temp Range	Package	Part Number
0 to 70°C	16-Pin Plastic DIP	DG271CJ
-40 to 85°C	16-Pin Narrow SOIC	DG271DY
-55 to 125°C	16-Pin CerDIP	DG271AK
		DG271AK/883
		5962-8671602MEA
	LCC-20	DG271AZ/883
		5962-8671602M2A

Truth Table

Logic	Switch
0	ON
1	OFF

Logic "0" ≤ 0.8 V
Logic "1" ≥ 2 V
Switches Shown for Logic "1" Input



Absolute Maximum Ratings

V+ to V-	44 V
GND to V-	25 V
Digital Inputs ^a V _S , V _D	(V-) -2 V to (V+) +2 V or 20 mA, whichever occurs first
Current, Any Terminal Except S or D	30 mA
Continuous Current, S or D	20 mA
Peak Current, S or D	
(Pulsed at 1 ms, 10% duty cycle max)	100 mA
Storage Temperature	(AK, AZ, DY Suffix) -65 to 150°C
(CJ Suffix)	-65 to 125°C
Power Dissipation (Package) ^b	
16-Pin Plastic DIP ^c	470 mW
16-Pin Plastic Narrow SOIC ^d	600 mW
16-Pin CerDIP ^e	900 mW
LCC-20 ^f	750 mW

Notes:

- Signals on S_X, D_X, or IN_X exceeding V+ or V- will be clamped by internal diodes. Limit forward diode current to maximum current ratings.
- All leads welded or soldered to PC Board.
- Derate 6.5 mW/°C above 75°C
- Derate 7.6 mW/°C above 75°C
- Derate 12 mW/°C above 75°C
- Derate 10 mW/°C above 75°C

Specifications^a

Parameter	Symbol	Test Conditions Unless Otherwise Specified V+ = 15 V, V- = -15 V V _{IN} = 2 V, 0.8 V ^f	Temp ^b	Typ ^c	A Suffix -55 to 125°C		C, D Suffix 0 to 70°C -40 to 85°C		Unit
					Min ^d	Max ^d	Min ^d	Max ^d	
Analog Switch									
Analog Signal Range ^e	V _{ANALOG}		Full		-15	15	-15	15	V
Drain-Source On-Resistance	r _{DS(on)}	I _S = 1 mA, V _D = ±10 V	Room Full	32		50 75		50 75	Ω
Switch Off Leakage Current	I _{S(off)}	V _D = ±14 V, V _S = ∓14 V	Room Full	±0.05	-1 -100	1 100	-1 -100	1 100	nA
	I _{D(off)}		Room Full	±0.05	-1 -100	1 100	-1 -100	1 100	
Channel On Leakage Current	I _{D(on)} + I _{S(on)}	V _S = V _D = ±14 V	Room Full	±0.05	-1 -200	1 200	-1 -200	1 200	
Digital Control									
Input Current with Voltage High	I _{INH}	V _{IN} = 2 V	Room Full	0.010	-1 -10		-1 -10		μA
		V _{IN} = 15 V	Room Full	0.010		1 10		1 10	
Input Current with Voltage Low	I _{INL}	V _{IN} = 0 V	Room Full	0.010	-1 -10		-1 -10		
Dynamic Characteristics									
Turn-On Time	t _{ON}	V _S = ±10 V See Figure 2	Room Full	55		65 80		65 80	ns
Turn-Off Time	t _{OFF}		Room Full	50		65 80		65 80	
Charge Injection	Q	C _L = 100 pF, V _{gen} = 0 V R _{gen} = 0 Ω	Room	9					pC

Specifications^a

Parameter	Symbol	Test Conditions Unless Otherwise Specified $V_+ = 15\text{ V}, V_- = -15\text{ V}$ $V_{IN} = 2\text{ V}, 0.8\text{ V}^f$	Temp ^b	Typ ^c	A Suffix -55 to 125°C		C, D Suffix 0 to 70°C -40 to 85°C		Unit
					Min ^d	Max ^d	Min ^d	Max ^d	
Dynamic Characteristics (Cont'd)									
Source Off Capacitance	$C_{S(off)}$	$V_S = 0\text{ V}, V_{IN} = 5\text{ V}$ $f = 1\text{ MHz}$	Room	6					pF
Drain Off Capacitance	$C_{D(off)}$		Room	8					
Channel On Capacitance	$C_{D(on)}$	$V_D = V_S = 0\text{ V}, V_{IN} = 0\text{ V}$	Room	24					dB
Off Isolation	OIRR		Room	75					
Crosstalk	XTALK	$R_L = 50\ \Omega, f = 1\text{ MHz}$	Room	95					
Supply									
Positive Supply Current	I_+	All Channels On or Off	Room Full	4.3		7.5 11		7.5 11	mA
Negative Supply Current	I_-		Room Full	-3.4	-6 -10		-6 -10		

Notes:

- a. Refer to PROCESS OPTION FLOWCHART (Section 5 of the 1994 Data Book or FaxBack number 7103).
- b. Room = 25°C, Full = as determined by the operating temperature suffix.
- c. Typical values are for DESIGN AID ONLY, not guaranteed nor subject to production testing.
- d. The algebraic convention whereby the most negative value is a minimum and the most positive a maximum, is used in this data sheet.
- e. Guaranteed by design, not subject to production test.
- f. V_{IN} = input voltage to perform proper function.

Typical Characteristics

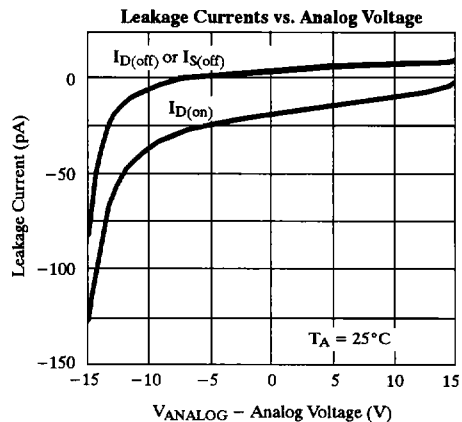
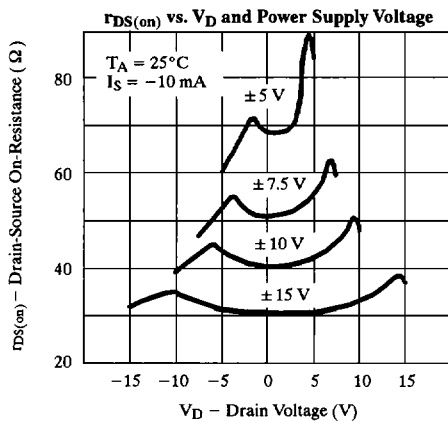

1

Typical Characteristics (Cont'd)

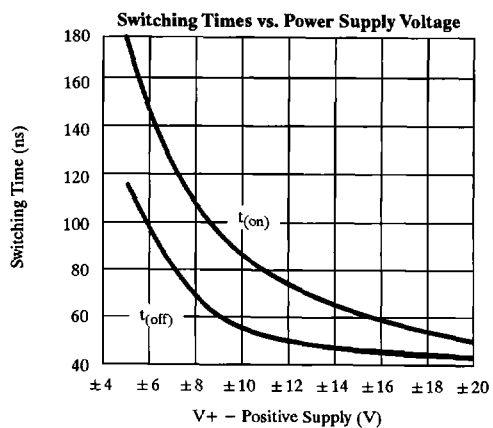
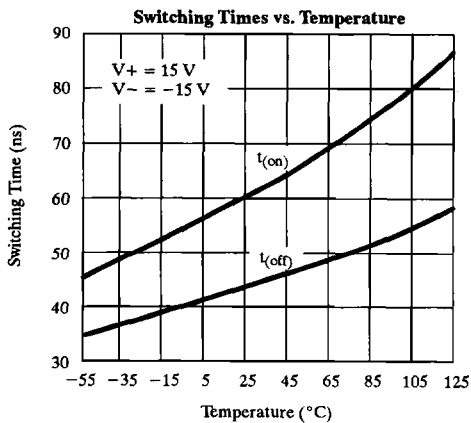
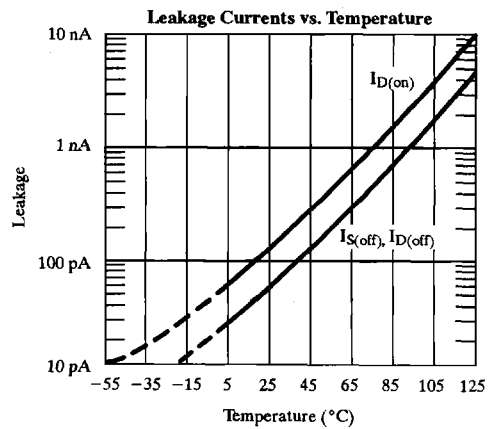
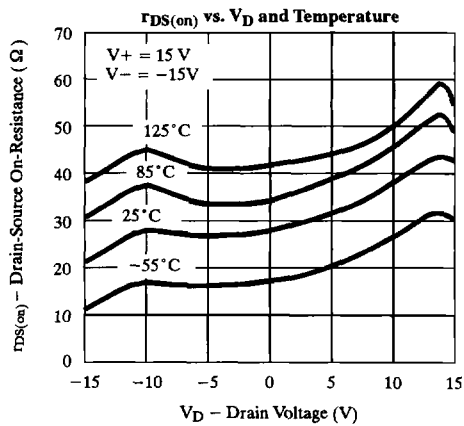
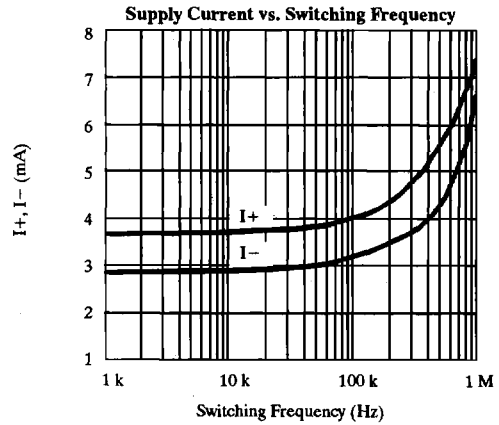
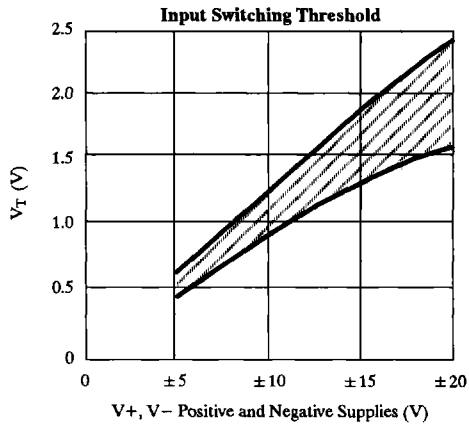

Schematic Diagram (Typical Channel)

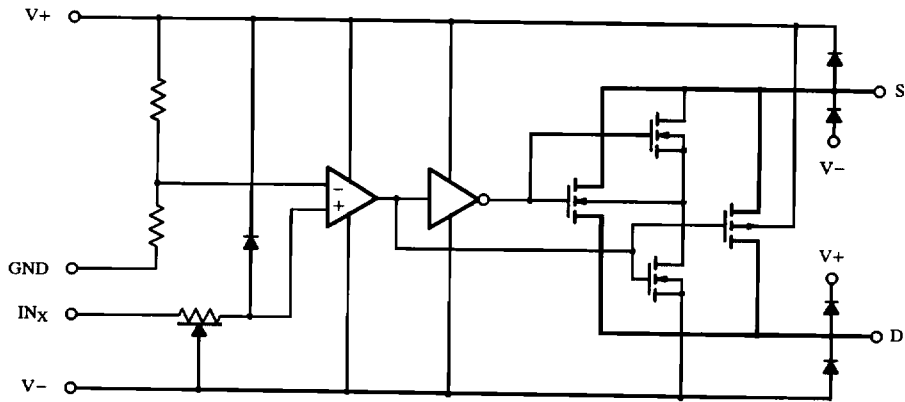

Figure 1.

Test Circuits

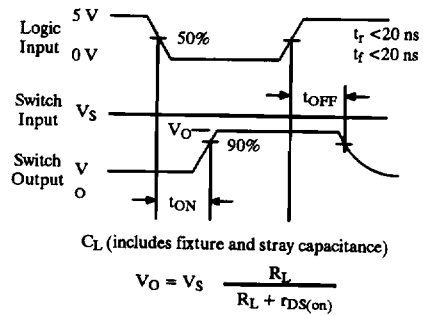
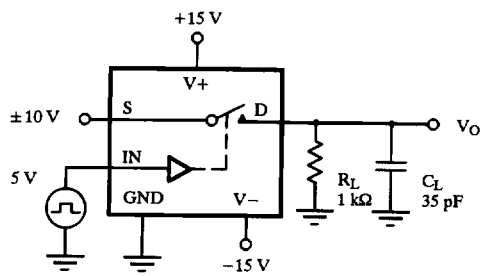

Figure 2. Switching Time

1