

Features

- High current operation for greater luminous output
- Low Power Consumption and thermal resistance
- Can be used with automatic insertion equipment
- RoHS Compliant



Benefits:

- Rugged design allows for easy maintenance
- Robust package for optimum reliability

Typical Applications:

- Automotive side markers
- Gaming and entertainment lighting
- Signs and road hazard indicators

Package Schematics

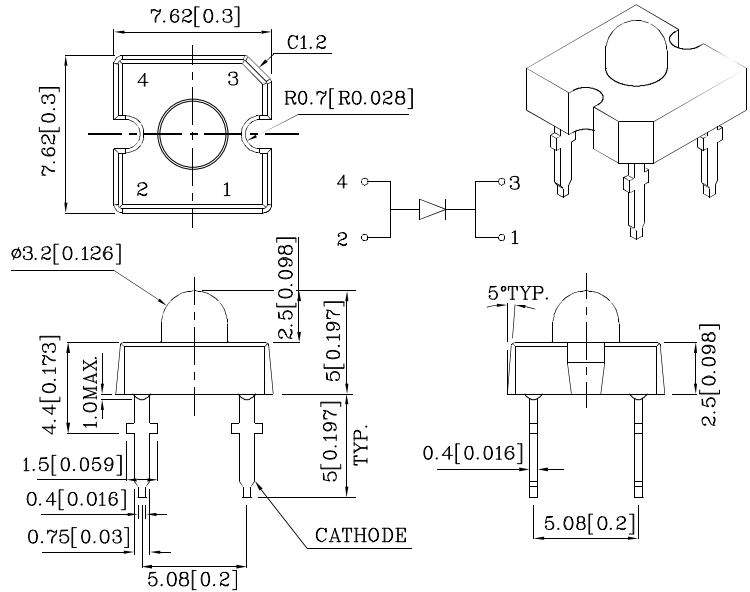

Notes:

1. All dimensions are in millimeters (inches).
2. Tolerance is $\pm 0.25(0.01")$ unless otherwise noted.
3. Specifications are subject to change without notice.

Absolute Maximum Ratings (T _A =25°C)		M2ACY (AlGaInP)	Unit
Reverse Voltage	V _R	5	V
DC Forward Current	I _F	70	mA
Power Dissipation	P _D	210	mW
Operating Temperature	T _A	-40 ~ +85	°C
Storage Temperature	T _{stg}	-55 ~ +85	
Lead Solder Temperature [1.5mm Below Seating Plane.][1]		260°C For 5 Seconds	

1.No Reflow soldering .

Operating Characteristics (T _A =25°C)		M2ACY (AlGaInP)	Unit
Forward Voltage (Min.) (I _F =70mA)	V _F	2.0	V
Forward Voltage (Typ.) (I _F =70mA)	V _F	2.2	V
Forward Voltage (Max.) (I _F =70mA)	V _F	3.0	V
Reverse Current (Max.) (V _R =5V)	I _R	10	uA
Wavelength of Peak Emission CIE127-2007*(Typ.) (I _F =70mA)	λ_P	590 590*	nm
Wavelength of Dominant Emission CIE127-2007*(Typ.) (I _F =70mA)	λ_D	589 590*	nm
Spectral Line Full Width At Half Maximum (Typ.) (I _F =70mA)	$\Delta\lambda$	20	nm
Capacitance (Typ.) (V _F =0V, f=1MHz)	C	45	pF
Thermal Resistance (Typ.)	R θ j-pin	125	°C/W

Part Number	Emitting Color	Emitting Material	Lens-color	Luminous Intensity CIE127-2007* (I _F =70mA) cd			Luminous Flux CIE127-2007* (I _F =70mA) lm	Wavelength CIE127-2007* λ_P nm	Viewing Angle 2 θ 1/2
				min.	typ.	typ.			
XSM2ACY783W	Yellow	AlGaInP	Water Clear	7*	13*	7.1*	590*	30°	

1.Luminous intensity is measured with an integrating sphere after the device has stabilized.

2.0 1/2 is the angle from optical centerline where the luminous intensity is 1/2 of the optical peak value.

3. LEDs are binned according to their Luminous intensity.

* Luminous intensity / luminous flux value and wavelength are in accordance with CIE127-2007 standards.

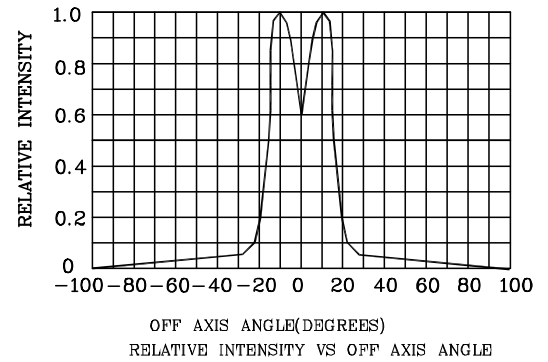
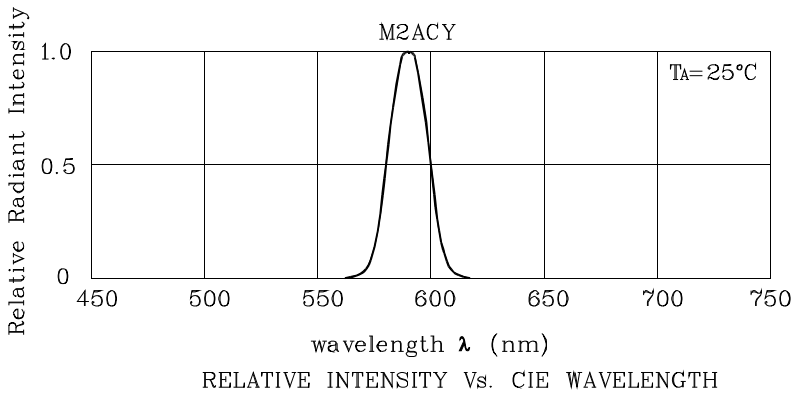

❖ M2ACY

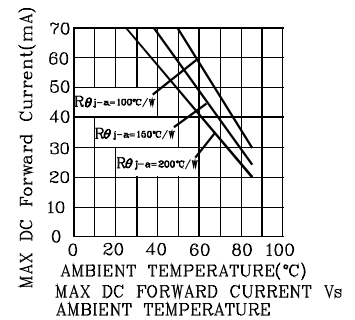
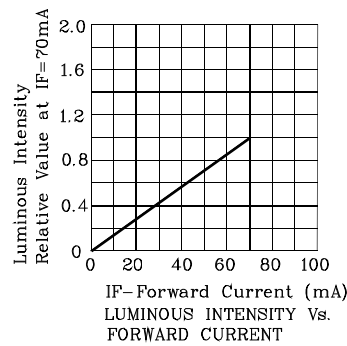
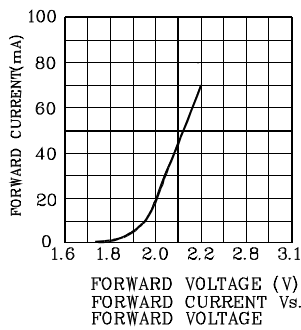

Wave Soldering Profile For Thru-Hole Products (Pb-Free Components)

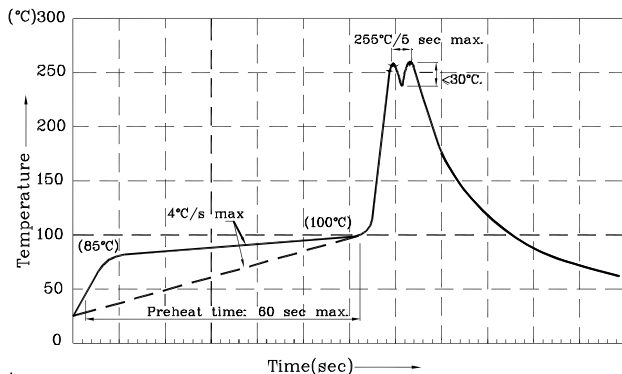

Notes:

- 1.Recommend pre-heat temperature of 105°C or less (as measured with a thermocouple attached to the LED pins) prior to immersion in the solder wave with a maximum solder bath temperature of 260°C
- 2.Peak wave soldering temperature between 245°C ~ 255°C for 3 sec (5 sec max).
- 3.Do not apply stress to the epoxy resin while the temperature is above 85°C.
- 4.Fixtures should not incur stress on the component when mounting and during soldering process.
- 5.SAC 305 solder alloy is recommended.
- 6.No more than one wave soldering pass.

Remarks:



If special sorting is required (e.g. binning based on forward voltage, luminous intensity / luminous flux, or wavelength), the typical accuracy of the sorting process is as follows:



1. Wavelength: +/-1nm
2. Luminous Intensity / Luminous Flux: +/-15%
3. Forward Voltage: +/-0.1V

Note: Accuracy may depend on the sorting parameters.

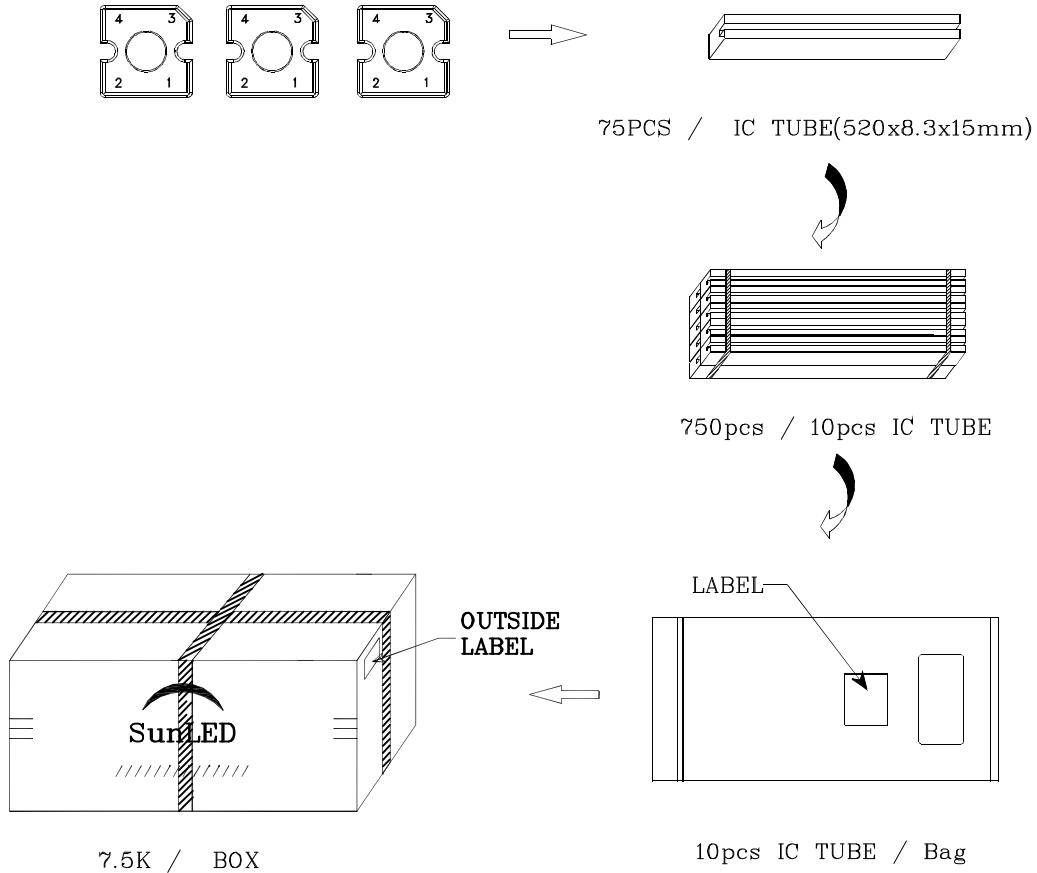

PACKING & LABEL SPECIFICATIONS

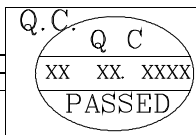
	
P/NO : XSxxx783x	
QTY : 750 pcs	CODE: XXX
S/N : XX	
LOT NO:	
	
RoHS Compliant	