

SN5440, SN54LS40, SN54S40, SN7440, SN74LS40, SN74S40 DUAL 4-INPUT POSITIVE-NAND BUFFERS

APRIL 1985 - REVISED MARCH 1988

- Package Options Include Plastic "Small Outline" Packages, Ceramic Chip Carriers and Flat Packages in Addition to Plastic and Ceramic DIPs
- Dependable Texas Instruments Quality and Reliability

description

These devices contain two independent 4-input NAND buffer gates.

The SN5440, SN54LS40, and SN54S40 are characterized for operation over the full military temperature range of -55°C to 125°C . The SN7440, SN74LS40, and SN74S40 are characterized for operation from 0°C to 70°C .

FUNCTION TABLE (each gate)

INPUTS				OUTPUT
A	B	C	D	Y
H	H	H	H	L
L	X	X	X	H
X	L	X	X	H
X	X	L	X	H
X	X	X	L	H

logic symbol†

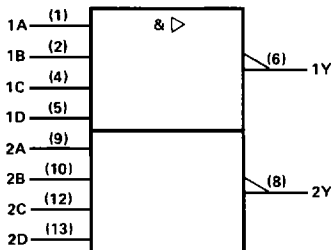

† This symbol is in accordance with ANSI/IEEE Std. 91-1984 and IEC Publication 617-12. Pin numbers shown are for D, J, N, and W packages

SN5440 . . . J PACKAGE
SN54LS40, SN54S40 . . . J OR W PACKAGE
SN7440 . . . N PACKAGE
SN74LS40, SN74S40 . . . D OR N PACKAGE
(TOP VIEW)

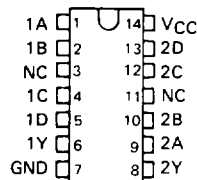

SN5440 . . . W PACKAGE
(TOP VIEW)

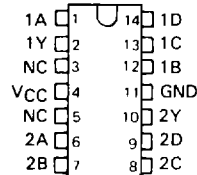

SN54LS40, SN54S40 . . . FK PACKAGE
(TOP VIEW)

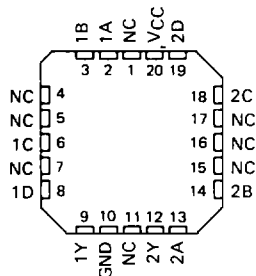

NC - No internal connection

logic diagram

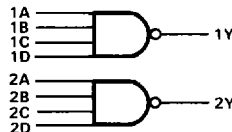

positive logic

$$Y = A \cdot B \cdot C \cdot D \text{ or } Y = \bar{A} + \bar{B} + \bar{C} + \bar{D}$$

2

TTL Devices

**SN5440, SN54LS40, SN54S40,
SN7440, SN74LS40, SN74S40
DUAL 4-INPUT POSITIVE-NAND BUFFERS**

schematics (each gate)

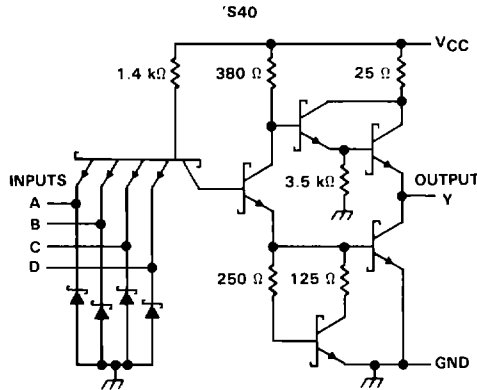
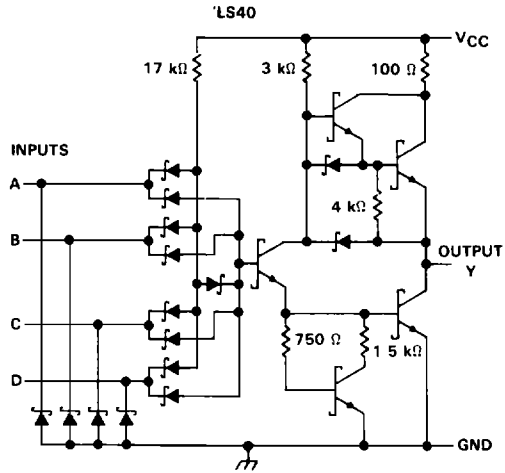
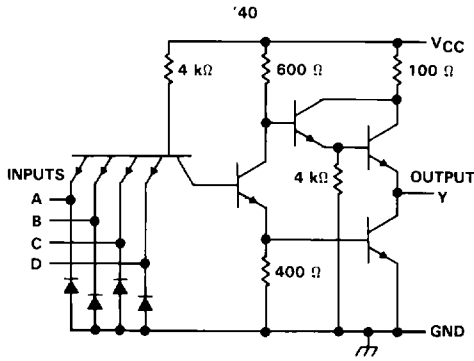

Resistor values shown are nominal

absolute maximum ratings over operating free-air temperature range (unless otherwise noted)

Supply voltage, V_{CC} (see Note 1)	7 V
Input voltage: '40, 'S40	5.5 V
'LS40	7 V
Operating free-air temperature range: SN54'	-55°C to 125°C
SN74'	0°C to 70°C
Storage temperature range	-65°C to 150°C

NOTE 1 Voltage values are with respect to network ground terminal

SN5440, SN7440 DUAL 4-INPUT POSITIVE-NAND BUFFERS

recommended operating conditions

	SN5440			SN7440			UNIT
	MIN	NOM	MAX	MIN	NOM	MAX	
V _{CC} Supply voltage	4.5	5	5.5	4.75	5	5.25	V
V _{IH} High-level input voltage	2			2			V
V _{IL} Low-level input voltage	0.8			0.8			V
I _{OH} High-level output current	-1.2			-1.2			mA
I _{OL} Low-level output current	48			48			mA
T _A Operating free-air temperature	-55 125			0 70			°C

electrical characteristics over recommended operating free-air temperature range (unless otherwise noted)

PARAMETER	TEST CONDITIONS †	SN5440			SN7440			UNIT
		MIN	TYP ‡	MAX	MIN	TYP ‡	MAX	
V _{IK}	V _{CC} = MIN, I _I = -12 mA	-1.5			-1.5			V
V _{OH}	V _{CC} = MIN, V _{IL} = 0.8 V, I _{OH} = -1.2 mA	2.4	3.3		2.4	3.3		V
V _{OL}	V _{CC} = MIN, V _{IH} = 2 V, I _{OL} = 48 mA	0.2	0.4		0.2	0.4		V
I _I	V _{CC} = MAX, V _I = 5.5 V	1			1			mA
I _{IH}	V _{CC} = MAX, V _I = 2.4 V	40			40			µA
I _{IL}	V _{CC} = MAX, V _I = 0.4 V	-1.6			-1.6			mA
I _{OS} §	V _{CC} = MAX	-20		-70	-18		-70	mA
I _{CCH}	V _{CC} = MAX, V _I = 0	4 8			4 8			mA
I _{CCL}	V _{CC} = MAX, V _I = 4.5 V	17 27			17 27			mA

† For conditions shown as MIN or MAX, use the appropriate value specified under recommended operating conditions

‡ All typical values are at V_{CC} = 5 V, T_A = 25°C

§ Not more than one output should be shorted at a time, and the duration of the short circuit should not exceed 100 milliseconds.

switching characteristics, V_{CC} = 5 V, T_A = 25°C (see note 2)

PARAMETER	FROM (INPUT)	TO (OUTPUT)	TEST CONDITIONS	MIN	TYP	MAX	UNIT
t _{PLH}	Any	Y	R _L = 133 Ω, C _L = 15 pF	13		22	ns
t _{PHL}				8		15	ns

NOTE 2 Load circuits and voltage waveforms are shown in Section 1

2

TTL Devices

SN54LS40, SN74LS40

DUAL 4-INPUT POSITIVE-NAND BUFFERS

recommended operating conditions

	SN54LS40			SN74LS40			UNIT
	MIN	NOM	MAX	MIN	NOM	MAX	
V _{CC} Supply voltage	4.5	5	5.5	4.75	5	5.25	V
V _{IH} High-level input voltage	2			2			V
V _{IL} Low-level input voltage			0.7			0.8	V
I _{OH} High-level output current			-1.2			-1.2	mA
I _{OL} Low-level output current			12			24	mA
T _A Operating free-air temperature	-55		125	0		70	°C

electrical characteristics over recommended operating free-air temperature range (unless otherwise noted)

PARAMETER	TEST CONDITIONS †	SN54LS40			SN74LS40			UNIT
		MIN	TYP ‡	MAX	MIN	TYP ‡	MAX	
V _{IK}	V _{CC} = MIN, I _I = -18 mA			-1.5			-1.5	V
V _{OH}	V _{CC} = MIN, V _{IL} = MAX, I _{OH} = -1.2 mA	2.5	3.4		2.7	3.4		V
V _{OL}	V _{CC} = MIN, V _{IH} = 2 V, I _{OL} = 12 mA		0.25	0.4		0.25	0.4	V
	V _{CC} = MIN, V _{IH} = 2 V, I _{OL} = 24 mA					0.35	0.5	
I _I	V _{CC} = MAX, V _I = 7 V			0.1			0.1	mA
I _{IH}	V _{CC} = MAX, V _I = 2.7 V			20			20	μA
I _{IL}	V _{CC} = MAX, V _I = 0.4 V			-0.4			-0.4	mA
I _{OS} §	V _{CC} = MAX	-30		-130	-30		-130	mA
I _{CCH}	V _{CC} = MAX, V _I = 0		0.45	1		0.45	1	mA
I _{CCL}	V _{CC} = MAX, V _I = 4.5 V		3	6		3	6	mA

† For conditions shown as MIN or MAX, use the appropriate value specified under recommended operating conditions.

‡ All typical values are at V_{CC} = 5 V, T_A = 25°C.

§ Not more than one output should be shorted at a time, and the duration of the short circuit should not exceed one second.

switching characteristics, V_{CC} = 5 V, T_A = 25°C (see note 2)

PARAMETER	FROM (INPUT)	TO (OUTPUT)	TEST CONDITIONS			MIN	TYP	MAX	UNIT
t _{PLH}	Any	Y	R _L = 667 Ω,	C _L = 45 pF		12	24	ns	
t _{PHL}						12	24		

NOTE 2 Load circuits and voltage waveforms are shown in Section 1

2

TTL Devices

SN54S40, SN74S40 DUAL 4-INPUT POSITIVE-NAND BUFFERS

recommended operating conditions

	SN54S40			SN74S40			UNIT
	MIN	NOM	MAX	MIN	NOM	MAX	
V _{CC} Supply voltage	4.5	5	5.5	4.75	5	5.25	V
V _{IH} High-level input voltage	2			2			V
V _{IL} Low-level input voltage				0.8			V
I _{OH} High-level output current				-3			mA
I _{OL} Low-level output current				60			mA
T _A Operating free-air temperature	-55			125			°C

electrical characteristics over recommended operating free-air temperature range (unless otherwise noted)

PARAMETER	TEST CONDITIONS †	SN54S40			SN74S40			UNIT
		MIN	TYP ‡	MAX	MIN	TYP ‡	MAX	
V _{IK}	V _{CC} = MIN, I _I = -18 mA	-1.2			-1.2			V
V _{OH}	V _{CC} = MIN, V _{IL} = 0.8 V, I _{OH} = -3 mA	2.5	3.4		2.7	3.4	V	
V _{OL}	V _{CC} = MIN, V _{IH} = 2 V, I _{OL} = 60 mA	0.5			0.5			V
I _I	V _{CC} = MAX, V _I = 5.5 V	1			1			mA
I _{IH}	V _{CC} = MAX, V _I = 2.7 V	0.1			0.1			mA
I _{IL}	V _{CC} = MAX, V _I = 0.5 V	-4			-4			mA
I _{OS} §	V _{CC} = MAX	-50		-225	-50		-225	mA
I _{CCH}	V _{CC} = MAX, V _I = 0	10 18			10 18			mA
I _{CCL}	V _{CC} = MAX, V _I = 4.5 V	25 44			25 44			mA

† For conditions shown as MIN or MAX, use the appropriate value specified under recommended operating conditions.

‡ All typical values are at V_{CC} = 5 V, T_A = 25°C.

§ Not more than one output should be shorted at a time, and the duration of the short-circuit should not exceed 100 milliseconds.

switching characteristics, V_{CC} = 5 V, T_A = 25°C (see note 2)

PARAMETER	FROM (INPUT)	TO (OUTPUT)	TEST CONDITIONS	MIN	TYP	MAX	UNIT
t _{PLH}	Any	Y	R _L = 93 Ω, C _L = 50 pF	4	6.5	ns	
t _{PHL}				4	6.5	ns	
t _{PLH}			R _L = 93 Ω, C _L = 150 pF	6	ns		
t _{PHL}				6	ns		

NOTE 2: Load circuits and voltage waveforms are shown in Section 1

2

TTL Devices