

SN74LVC244 OCTAL BUFFER/DRIVER WITH 3-STATE OUTPUTS

SCAS414 – NOVEMBER 1992 – REVISED MARCH 1994

- **EPIC™** (Enhanced-Performance Implanted CMOS) Submicron Process
- **Typical V_{OLP} (Output Ground Bounce)**
< 0.8 V at $V_{CC} = 3.3$ V, $T_A = 25^\circ\text{C}$
- **Typical V_{OHV} (Output V_{OH} Undershoot)**
> 2 V at $V_{CC} = 3.3$ V, $T_A = 25^\circ\text{C}$
- **Package Options include Plastic Small-Outline (DW), Shrink Small-Outline (DB), and Thin Shrink Small-Outline (PW) Packages**

DB, DW, OR PW PACKAGE
(TOP VIEW)

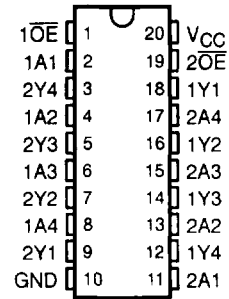

description

This octal buffer/line driver is designed for 2.7-V to 3.6-V V_{CC} operation.

The SN74LVC244 is organized as two 4-bit line drivers with separate output-enable (\overline{OE}) inputs. When \overline{OE} is low, the device passes data from the A inputs to the Y outputs. When \overline{OE} is high, the outputs are in the high-impedance state.

The SN74LVC244 is characterized for operation from -40°C to 85°C .

FUNCTION TABLE
(each buffer)

INPUTS		OUTPUT
\overline{OE}	A	Y
L	H	H
L	L	L
H	X	Z

EPIC is a trademark of Texas Instruments Incorporated.

PRODUCT PREVIEW Information concerns products in the formative or design phase of development. Characteristic data and other specifications are design goals. Texas Instruments reserves the right to change or discontinue these products without notice.

 **TEXAS
INSTRUMENTS**

POST OFFICE BOX 655303 • DALLAS, TEXAS 75265

Copyright © 1994, Texas Instruments Incorporated

PRODUCT PREVIEW

SN74LVC244

OCTAL BUFFER/DRIVER WITH 3-STATE OUTPUTS

SCAS414 – NOVEMBER 1982 – REVISED MARCH 1984

logic symbol†

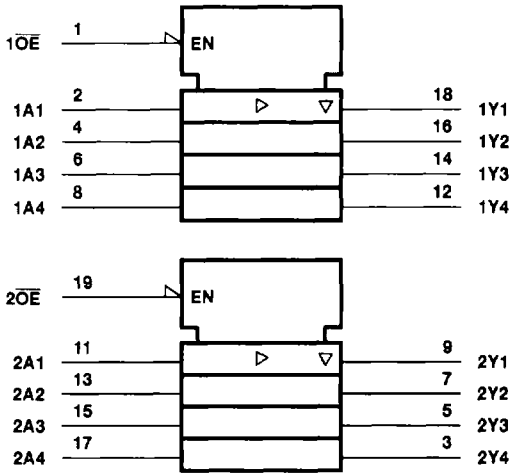

† This symbol is in accordance with ANSI/IEEE Std 91-1984 and IEC Publication 617-12.

logic diagram (positive logic)

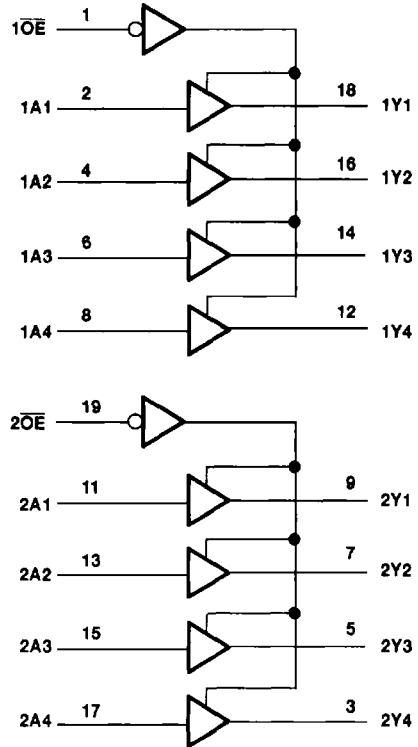

PRODUCT PREVIEW

absolute maximum ratings over operating free-air temperature range (unless otherwise noted)‡

Supply voltage range, V_{CC}	-0.5 V to 4.6 V
Input voltage range, V_I	-0.5 V to 4.6 V
Output voltage range, V_O (see Note 1)	-0.5 V to $V_{CC} + 0.5$ V
Input clamp current, I_{IK} ($V_I < 0$)	-50 mA
Output clamp current, I_{OK} ($V_O < 0$ or $V_O > V_{CC}$)	± 50 mA
Continuous output current, I_O ($V_O = 0$ to V_{CC})	± 50 mA
Continuous current through V_{CC} or GND pins	± 100 mA
Maximum power dissipation at $T_A = 55^\circ\text{C}$ (in still air):	
DB package	0.6 W
DW package	1.6 W
PW package	0.7 W
Storage temperature range	-65°C to 150°C

‡ Stresses beyond those listed under "absolute maximum ratings" may cause permanent damage to the device. These are stress ratings only, and functional operation of the device at these or any other conditions beyond those indicated under "recommended operating conditions" is not implied. Exposure to absolute-maximum-rated conditions for extended periods may affect device reliability.

NOTE 1: This value is limited to 4.6 V maximum.



POST OFFICE BOX 655303 • DALLAS, TEXAS 75265

SN74LVC244 OCTAL BUFFER/DRIVER WITH 3-STATE OUTPUTS

SCAS414 – NOVEMBER 1992 – REVISED MARCH 1994

recommended operating conditions (see Note 2)

		MIN	MAX	UNIT
V _{CC}	Supply voltage	2.7	3.6	V
V _{IH}	High-level input voltage	V _{CC} = 2.7 V to 3.6 V		V
V _{IL}	Low-level input voltage	V _{CC} = 2.7 V to 3.6 V		V
V _I	Input voltage	0	V _{CC}	V
V _O	Output voltage	0	V _{CC}	V
I _{OH}	High-level output current	V _{CC} = 2.7 V		mA
		V _{CC} = 3 V		
I _{OL}	Low-level output current	V _{CC} = 2.7 V		mA
		V _{CC} = 3 V		
Δt/Δv	Input transition rise or fall rate	0	10	ns/V
T _A	Operating free-air temperature	-40	85	°C

NOTE 2: Unused or floating inputs must be held high or low.

electrical characteristics over recommended operating free-air temperature range (unless otherwise noted)

PARAMETER	TEST CONDITIONS	V _{CC} †	T _A = -40°C to 85°C			UNIT
			MIN	TYP	MAX	
V _{OH}	I _{OH} = -100 μA	MIN to MAX	V _{CC} -0.2			V
	I _{OH} = -12 mA	2.7 V	2.2			
	I _{OH} = -24 mA	3 V	2.4			
V _{OL}	I _{OL} = 100 μA	MIN to MAX	0.2			V
	I _{OL} = 12 mA	2.7 V	0.4			
	I _{OL} = 24 mA	3 V	0.55			
I _I	V _I = V _{CC} or GND	3.6 V	±5			μA
I _{OZ}	V _O = V _{CC} or GND	3.6 V	±10			μA
I _{CC}	V _I = V _{CC} or GND, I _O = 0	3.6 V	20			μA
ΔI _{CC}	V _{CC} = 3 V to 3.6 V, One input at V _{CC} - 0.6 V, Other inputs at V _{CC} or GND		500			μA
C _i	V _I = V _{CC} or GND	3.3 V	3			pF
C _o	V _O = V _{CC} or GND	3.3 V	3.5			pF

† For conditions shown as MIN or MAX, use the appropriate values under recommended operating conditions.

switching characteristics over recommended operating free-air temperature range, C_L = 50 pF (unless otherwise noted) (see Note 3)

PARAMETER	FROM (INPUT)	TO (OUTPUT)	V _{CC} = 3.3 V ± 0.3 V		V _{CC} = 2.7 V		UNIT
			MIN	MAX	MIN	MAX	
t _{pd}	A	Y	1.5	7	8		ns
t _{en}	OE	Y	1.5	8	9.2		ns
t _{dis}	OE	Y	1.5	7.5	8.5		ns

NOTE 3: Load circuit and voltage waveforms are shown in Section 1.



SN74LVC244
OCTAL BUFFER/DRIVER
WITH 3-STATE OUTPUTS

SCAS414 – NOVEMBER 1992 – REVISED MARCH 1994

operating characteristics, $V_{CC} = 3.3\text{ V}$, $T_A = 25^\circ\text{C}$

PARAMETER		TEST CONDITIONS	TYP	UNIT
C_{pd} Power dissipation capacitance per buffer/driver	Outputs enabled	$C_L = 50\text{ pF}$, $f = 10\text{ MHz}$	20	pF
	Outputs disabled		2	

PRODUCT PREVIEW

