

TYPES SN54157, SN54L157, SN54LS157, SN54LS158, SN54S157, SN54S158, SN74157, SN74LS157, SN74LS158, SN74S157, SN74S158 QUADRUPLE 2-LINE TO 1-LINE DATA SELECTORS/MULTIPLEXERS

MARCH 1974—REVISED DECEMBER 1983

- Buffered Inputs and Outputs
- Three Speed/Power Ranges Available

TYPES	TYPICAL AVERAGE PROPAGATION TIME	TYPICAL POWER DISSIPATION
'157	9 ns	150 mW
'L157	18 ns	75 mW
'LS157	9 ns	49 mW
'S157	5 ns	250 mW
'LS158	7 ns	24 mW
'S158	4 ns	195 mW

applications

- Expand Any Data Input Point
- Multiplex Dual Data Buses
- Generate Four Functions of Two Variables (One Variable Is Common)
- Source Programmable Counters

description

These monolithic data selectors/multiplexers contain inverters and drivers to supply full on-chip data selection to the four output gates. A separate strobe input is provided. A 4-bit word is selected from one of two sources and is routed to the four outputs. The '157, 'L157, 'LS157, and 'S157 present true data whereas the 'LS158 and 'S158 present inverted data to minimize propagation delay time.

FUNCTION TABLE

INPUTS				OUTPUT Y	
STROBE G	SELECT A/B	A	B	'157, 'L157, 'LS157, 'S157	'LS158 'S158
H	X	X	X	L	H
L	L	L	X	L	H
L	L	H	X	H	L
L	H	X	L	L	H
L	H	X	H	H	L

H = high level, L = low level, X = irrelevant

absolute maximum ratings over operating free-air temperature range (unless otherwise noted)

Supply voltage, V_{CC} (see Note 1)	7 V
Input voltage: '157, 'L157, 'S158	5.5 V
'LS157, 'LS158	7 V
Operating free-air temperature range: SN54'	-55°C to 125°C
SN74'	0°C to 70°C
Storage temperature range	-65°C to 150°C

NOTE 1: Voltage values are with respect to network ground terminal.

SN54157, SN54LS157, SN54S157,
SN54LS158, SN54S158 ... J OR W PACKAGE
SN54L157 ... J PACKAGE
SN74157 ... J OR N PACKAGE
SN74LS157, SN74S157,
SN74LS158, SN74S158 ... D, J OR N PACKAGE

(TOP VIEW)

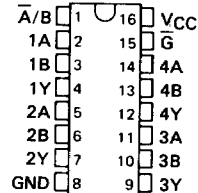

SN54LS157, SN54S157, SN54LS158,
SN54S158 ... FK PACKAGE
SN74LS157, SN74S157, SN74LS158,
SN74S158 ... FN PACKAGE

(TOP VIEW)

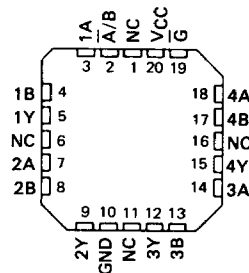

NC - No internal connection

3

TTL DEVICES

PRODUCTION DATA

This document contains information current as of publication date. Products conform to specifications per the terms of Texas Instruments standard warranty. Production processing does not necessarily include testing of all parameters.

TEXAS
INSTRUMENTS

POST OFFICE BOX 225012 • DALLAS, TEXAS 75285

3-589

TYPES SN54157, SN54L157, SN74157 QUADRUPLE 2-LINE TO 1-LINE DATA SELECTORS/MULTIPLEXERS

logic diagram

'157, 'L157

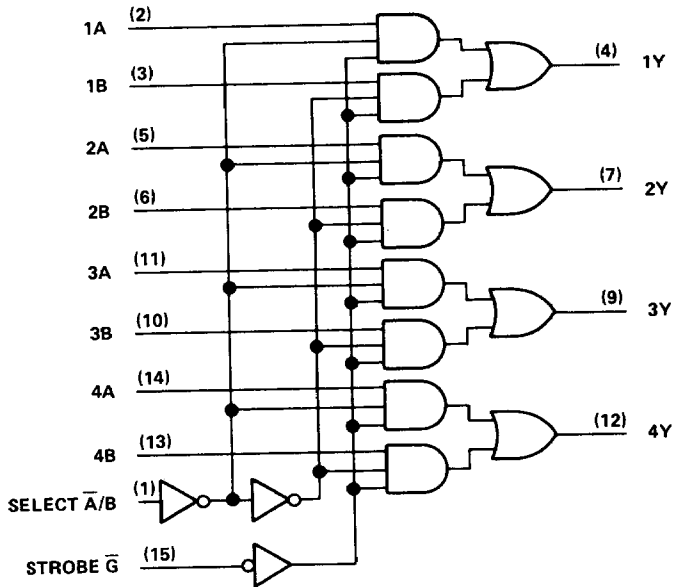

Pin numbers shown on logic notation are for D, J or N packages.

schematics of inputs and outputs

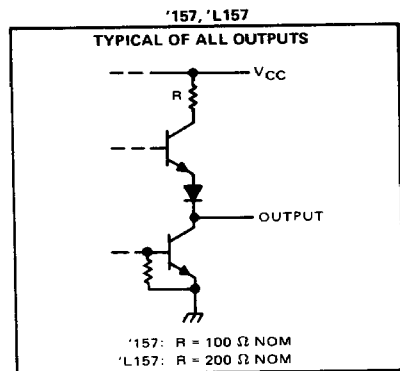
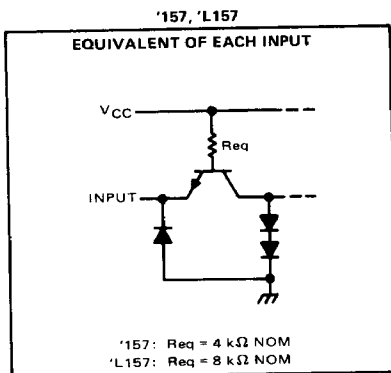

3

TTL DEVICES

TYPES SN54LS157, SN54LS158, SN54S157, SN54S158, SN74LS157, SN74LS158, SN74S157, SN74S158 QUADRUPLE 2-LINE TO 1-LINE DATA SELECTORS/MULTIPLEXERS

logic diagrams

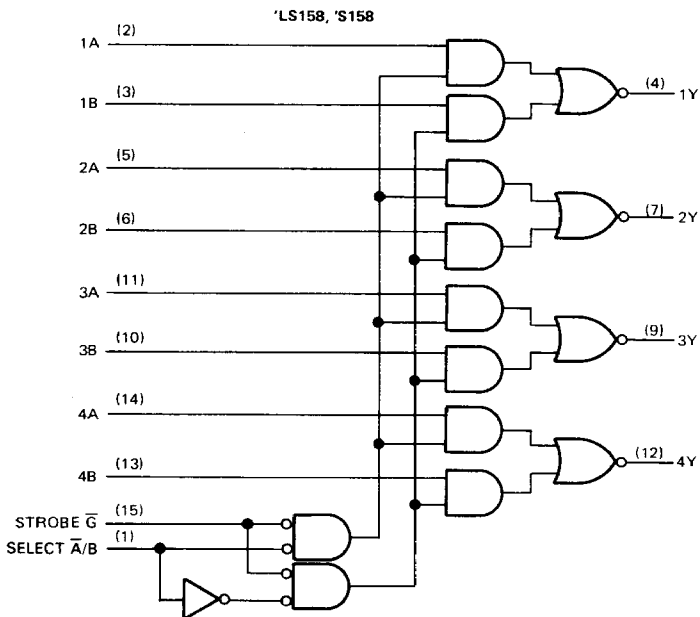
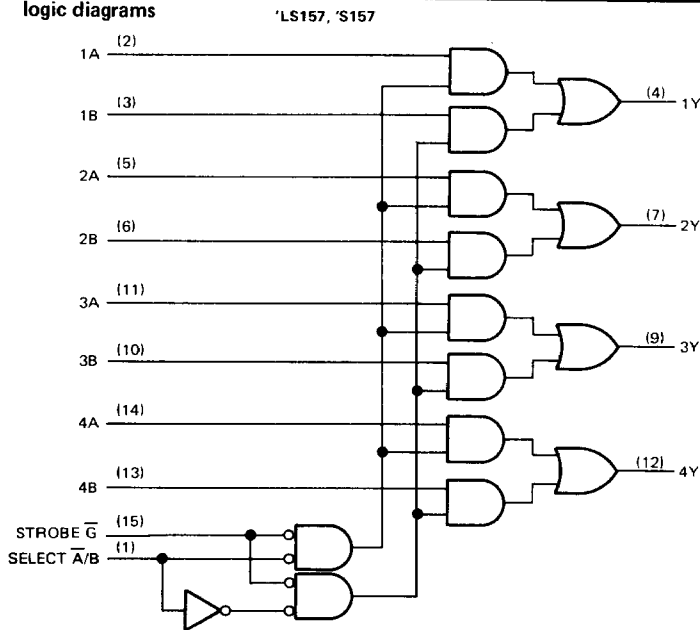

Pin numbers shown on logic notation are for D, J or N packages.

schematics of inputs and outputs

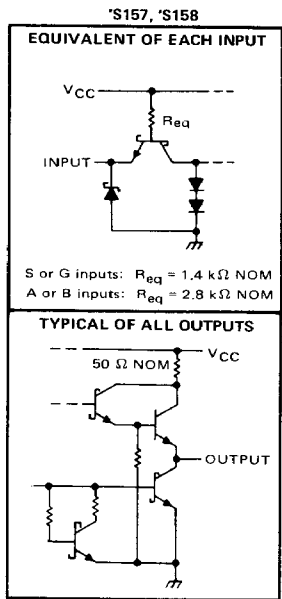
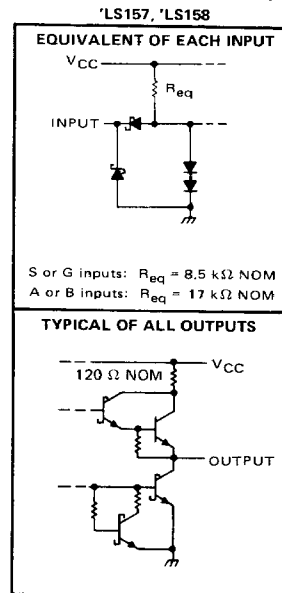

3

TTL DEVICES

TYPES SN54157, SN74157 QUADRUPLE 2-LINE TO 1-LINE DATA SELECTORS/MULTIPLEXERS

recommended operating conditions

	SN54157			SN74157			UNIT
	MIN	NOM	MAX	MIN	NOM	MAX	
Supply voltage, V_{CC}	4.5	5	5.5	4.75	5	5.25	V
High-level output current, I_{OH}			-800			-800	μ A
Low-level output current, I_{OL}			16			16	mA
Operating free-air temperature, T_A	-55		125	0		70	$^{\circ}$ C

electrical characteristics over recommended operating free-air temperature range (unless otherwise noted)

PARAMETER	TEST CONDITIONS†	SN54157			SN74157			UNIT
		MIN	TYP‡	MAX	MIN	TYP‡	MAX	
V_{IH} High-level input voltage		2			2			V
V_{IL} Low-level input voltage				0.8			0.8	V
V_{IK} Input clamp voltage	$V_{CC} = \text{MIN}, I_I = -12 \text{ mA}$			-1.5			-1.5	V
V_{OH} High-level output voltage	$V_{CC} = \text{MIN}, V_{IH} = 2 \text{ V}, V_{IL} = 0.8 \text{ V}, I_{OH} = -800 \mu\text{A}$	2.4	3.4		2.4	3.4		V
V_{OL} Low-level output voltage	$V_{CC} = \text{MIN}, V_{IH} = 2 \text{ V}, V_{IL} = 0.8 \text{ V}, I_{OL} = 16 \text{ mA}$		0.2	0.4		0.2	0.4	V
I_I Input current at maximum input voltage	$V_{CC} = \text{MAX}, V_I = 5.5 \text{ V}$			1			1	mA
I_{IH} High-level input current	$V_{CC} = \text{MAX}, V_I = 2.4 \text{ V}$			40			40	μ A
I_{IL} Low-level input current	$V_{CC} = \text{MAX}, V_I = 0.4 \text{ V}$			-1.6			-1.6	mA
I_{OS} Short-circuit output current‡	$V_{CC} = \text{MAX}$	-20		-55	-18		-55	mA
I_{CC} Supply current	$V_{CC} = \text{MAX}$, See Note 2		30	48		30	48	mA

3

† For conditions shown as MIN or MAX, use the appropriate value specified under recommended operating conditions.

‡ All typical values are at $V_{CC} = 5 \text{ V}, T_A = 25^{\circ}\text{C}$. *add as table note*

§ Not more than one output should be shorted at a time and duration of short-circuit should not exceed one second.

NOTE 2: I_{CC} is measured with 4.5 V applied to all inputs and all outputs open. *add*

TTL DEVICES

switching characteristics, $V_{CC} = 5 \text{ V}, T_A = 25^{\circ}\text{C}$

PARAMETER¶	FROM (INPUT)	TEST CONDITIONS	MIN	TYP	MAX	UNIT
t_{PLH}	Data	$C_L = 15 \text{ pF}, R_L = 400 \Omega,$ See Note 3		9	14	ns
t_{PHL}				9	14	
t_{PLH}	Strobe \bar{G}			13	20	ns
t_{PHL}				14	21	
t_{PLH}	Select \bar{A}/\bar{B}			15	23	ns
t_{PHL}				18	27	

¶ t_{PLH} = propagation delay time, low-to-high-level output

t_{PHL} = propagation delay time, high-to-low-level output

NOTE 3—See General Information Section for load circuits and voltage waveforms.

TYPE SN54L157

QUADRUPLE 2-LINE TO 1-LINE DATA SELECTORS/MULTIPLEXERS

recommended operating conditions

	MIN	NOM	MAX	UNIT
V _{CC} Supply voltage	4.5	5	5.5	V
I _{OH} High-level output current			-400	μA
I _{OL} Low-level output current			8	mA
T _A Operating free-air temperature	-55		125	°C

electrical characteristics over recommended operating free-air temperature range (unless otherwise noted)

PARAMETER	TEST CONDITIONS†	MIN	TYP‡	MAX	UNIT
V _{IH} High-level input voltage		2			V
V _{IL} Low-level input voltage				0.8	V
V _{IK} Input clamp voltage	V _{CC} = MIN, I _I = -12 mA			-1.5	V
V _{OH} High-level output voltage	V _{CC} = MIN, V _{IH} = 2 V, V _{IL} = 0.8 V, I _{OH} = -400 μA	2.4	3.4		V
V _{OL} Low-level output voltage	V _{CC} = MIN, V _{IH} = 2 V, V _{IL} = 0.8 V, I _{OL} = 8 mA		0.2	0.4	V
I _I Input current at maximum input voltage	V _{CC} = MAX, V _I = 5.5 V			1	mA
I _{IH} High-level input current	V _{CC} = MAX, V _I = 2.4 V			20	μA
I _{IL} Low-level input current	V _{CC} = MAX, V _I = 0.4 V			-0.8	mA
I _{OS} Short-circuit output current§	V _{CC} = MAX	-9		-28	mA
I _{CC} Supply current	V _{CC} = MAX, See Note 2		15	24	mA

† For conditions shown as MIN or MAX, use the appropriate value specified under recommended operating conditions.

‡ All typical values are at V_{CC} = 5 V, T_A = 25°C.

§ Not more than one output should be shorted at a time.

NOTE 2: I_{CC} is measured with 4.5 V applied to all inputs and all outputs open.

switching characteristics, V_{CC} = 5 V, T_A = 25°C

PARAMETER¶	FROM (INPUT)	TEST CONDITIONS	MIN	TYP	MAX	UNIT
†PLH	Data	C _L = 15 pF, R _L = 800 Ω, See Note 3	18	28		ns
†PHL			18	28		
†PLH	Strobe \bar{G}		26	40		ns
†PHL			28	42		
†PLH	Select \bar{A}/B		30	46		ns
†PHL			36	54		

¶ †PLH = propagation delay time, low-to-high-level output

†PHL = propagation delay time, high-to-low-level output

NOTE 3: See General Information Section for load circuits and voltage waveforms.

3

TTL DEVICES

TYPES SN54LS157, SN54LS158, SN74LS157, SN74LS158

QUADRUPLE 2-LINE TO 1-LINE DATA SELECTORS/MULTIPLEXERS

recommended operating conditions

	SN54LS'			SN74LS'			UNIT
	MIN	NOM	MAX	MIN	NOM	MAX	
V _{CC} Supply voltage	4.5	5	5.5	4.75	5	5.25	V
I _{OH} High-level output current	-400			-400			μA
I _{OL} Low-level output current	4			8			mA
T _A Operating free-air temperature	-55			125			0 70 °C

electrical characteristics over recommended operating free-air temperature range (unless otherwise noted)

PARAMETER	TEST CONDITIONS†	SN54LS'			SN74LS'			UNIT	
		MIN	TYP‡	MAX	MIN	TYP‡	MAX		
V _{IH} High-level input voltage		2			2			V	
V _{IL} Low-level input voltage		0.7			0.8			V	
V _{IK} Input clamp voltage	V _{CC} = MIN, I _I = -18 mA	-1.5			-1.5			V	
V _{OH} High-level output voltage	V _{CC} = MIN, V _{IH} = 2 V, V _{IL} = MAX, I _{OH} = -400 μA	2.5	3.4		2.7	3.4	V		
V _{OL} Low-level output voltage	V _{CC} = MIN, V _{IH} = 2 V, V _{IL} = MAX, I _{OL} = 4 mA	0.25 0.4			0.25 0.4			V	
		I _{OL} = 8 mA			0.35 0.5				
I _I Input current at maximum input voltage	V _{CC} = MAX, V _I = 7 V	A/B or G			0.2			mA	
		A or B			0.1				
I _{IH} High-level input current	V _{CC} = MAX, V _I = 2.7 V	A/B or G			40			μA	
		A or B			20				
I _{IL} Low-level input current	V _{CC} = MAX, V _I = 0.4 V	A/B or G			-0.8			mA	
		A or B			-0.4				
I _{OS} Short-circuit output current §	V _{CC} = MAX	-20	-100	-20	-100		mA		
I _{CC} Supply current	V _{CC} = MAX, See Note 2	'LS157			9.7 16			mA	
		'LS158			4.8 8				
		'LS158			6.5 11				
		V _{CC} = MAX, All A inputs at 4.5 V, All other inputs at 0 V			'LS158			6.5 11	

† For conditions shown as MIN or MAX, use the appropriate value specified under recommended operating conditions.

‡ All typical values are at V_{CC} = 5 V, T_A = 25° C.

§ Not more than one output should be shorted at a time and duration of short-circuit should not exceed one second.

NOTE 2: I_{CC} is measured with 4.5 V applied to all inputs and all outputs open.

switching characteristics, V_{CC} = 5 V, T_A = 25° C

PARAMETER ¶	FROM (INPUT)	TEST CONDITIONS	'LS157			'LS158			UNIT
			MIN	TYP	MAX	MIN	TYP	MAX	
t _{PLH}	Data	C _L = 15 pF, R _L = 2 kΩ, See Note 3	9 14			7 12			ns
t _{PHL}			9 14			10 15			
t _{PLH}	Strobe G		13 20			11 17			ns
t _{PHL}			14 21			18 24			
t _{PLH}	Select A/B		15 23			13 20			ns
t _{PHL}			18 27			16 24			

¶ t_{PLH} ≡ propagation delay time, low-to-high-level output

t_{PHL} ≡ propagation delay time, high-to-low-level output

NOTE 3: See General Information Section for load circuits and voltage waveforms.

3

TTL DEVICES

TYPES SN54S157, SN54S158, SN74S157, SN74S158 QUADRUPLE 2-LINE TO 1-LINE DATA SELECTORS/MULTIPLEXERS

recommended operating conditions

	SN54S157 SN54S158			SN74S157 SN74S158			UNIT
	MIN	NOM	MAX	MIN	NOM	MAX	
Supply voltage, V_{CC}	4.5	5	5.5	4.75	5	5.25	V
High-level output current, I_{OH}			-1			-1	mA
Low-level output current, I_{OL}			20			20	mA
Operating free-air temperature, T_A	-55		125	0		70	°C

electrical characteristics over recommended operating free-air temperature range (unless otherwise noted)

PARAMETER	TEST CONDITIONS†	SN54S157 SN74S157			SN54S158 SN74S158			UNIT
		MIN	TYP‡	MAX	MIN	TYP‡	MAX	
V_{IH} High-level input voltage		2			2			V
V_{IL} Low-level input voltage		0.8			0.8			V
V_{IK} Input clamp voltage	$V_{CC} = \text{MIN}, I_I = -18 \text{ mA}$	-1.2			-1.2			V
V_{OH} High-level output voltage	$V_{CC} = \text{MIN}, V_{IH} = 2 \text{ V},$ $V_{IL} = 0.8 \text{ V}, I_{OH} = -1 \text{ mA}$	Series 54S 2.5	3.4		Series 74S 2.5	3.4		V
V_{OL} Low-level output voltage	$V_{CC} = \text{MIN}, V_{IH} = 2 \text{ V},$ $V_{IL} = 0.8 \text{ V}, I_{OL} = 20 \text{ mA}$	0.5			0.5			V
I_I Input current at maximum input voltage	$V_{CC} = \text{MAX}, V_I = 5.5 \text{ V}$	1			1			mA
I_{IH} High-level input current	\bar{A}/\bar{B} or \bar{G}	100			100			μA
	A or B	50			50			
I_{IL} Low-level input current	\bar{A}/\bar{B} or \bar{G}	-4			-4			mA
	A or B	-2			-2			
I_{OS} Short-circuit output current§	$V_{CC} = \text{MAX}$	-40	-100		-40	-100	mA	
I_{CC} Supply current	$V_{CC} = \text{MAX},$ All inputs at 4.5 V, See Note 2	50	78		39	61	mA	
	$V_{CC} = \text{MAX},$ A inputs at 4.5 V, B,G,S, inputs at 0 V, See Note 2					81		

† For conditions shown as MIN or MAX, use the appropriate value specified under recommended operating conditions.

‡ All typical values are at $V_{CC} = 5 \text{ V}, T_A = 25^\circ\text{C}$.

§ Not more than one output should be shorted at a time, and duration of the short-circuit should not exceed one second.

Note 2: I_{CC} is measured with all outputs open.

switching characteristics, $V_{CC} = 5 \text{ V}, T_A = 25^\circ\text{C}$

PARAMETER¶	FROM (INPUT)	TEST CONDITIONS	SN54S157 SN74S157			SN54S158 SN74S158			UNIT
			MIN	TYP	MAX	MIN	TYP	MAX	
t_{PLH}	Data	$C_L = 15 \text{ pF},$ $R_L = 280 \Omega,$ See Note 3	5	7.5		4	6	ns	
t_{PHL}			4.5	6.5		4	6		
t_{PLH}	Strobe \bar{G}		8.5	12.5		6.5	11.5	ns	
t_{PHL}			7.5	12		7	12		
t_{PLH}	Select \bar{A}/\bar{B}		9.5	15		8	12	ns	
t_{PHL}			9.5	15		8	12		

¶ t_{PLH} ≡ propagation delay time, low-to-high-level output

t_{PHL} ≡ propagation delay time, high-to-low-level output

NOTE 3: See General Information Section for load circuits and voltage waveforms.

3

TTL DEVICES