

- **Separate Supply Voltage Pins for Isolation of Frequency Control Inputs and Oscillators from Output Circuitry**
- **Highly Stable Operation over Specified Temperature and/or Supply Voltage Ranges**

DEVICE TYPE	SIMILAR TO	NUMBER VCO's	COMP'L Z OUT	ENABLE	RANGE INPUT	R _{ext}
'LS624	'LS324	single	yes	yes	yes	no
'LS625	'LS325	dual	yes	no	no	no
'LS626	'LS326	dual	yes	yes	no	no
'LS627	'LS327	dual	no	no	no	no
'LS628	'LS324	single	yes	yes	yes	yes
'LS629	'LS124	dual	no	yes	yes	no

description

These voltage-controlled oscillators (VCOs) are improved versions of the original VCO family: SN54LS124, SN54LS324 thru SN54LS327, SN74LS124, and SN74LS324 thru SN74LS327. These new devices feature improved voltage-to-frequency linearity, range, and compensation. With the exception of the 'LS624 and 'LS628, all of these devices feature two independent VCOs in a single monolithic chip. The 'LS624, 'LS625, 'LS626, and 'LS628 have complementary Z outputs. The output frequency for each VCO is established by a single external component (either a capacitor or crystal) in combination with voltage-sensitive inputs used for frequency control and frequency range. Each device has a voltage-sensitive input for frequency control; however, the 'LS624, 'LS628, and 'LS629 devices also have one for frequency range. (See Figures 1 thru 6).

The 'LS628 offers more precise temperature compensation than its 'LS624 counterpart. The 'LS624 features a 600 ohm internal timing resistor. The 'LS628 requires a timing resistor to be connected externally across R_{EXT} pins. Temperature compensation will be improved due to the temperature coefficient of the external resistor.

Figure 3 and Figure 6 contain the necessary information to choose the proper capacitor value to obtain the desired operating frequency.

A single 5-volt supply can be used; however, one set of supply voltage and ground pins (V_{CC} and GND) is provided for the enable, synchronization-gating, and output sections, and a separate set (OSC V_{CC} and OSC GND) is provided for the oscillator and associated frequency-control circuits so that effective isolation can be accomplished in the system. For operation of frequencies greater than 10 MHz, it is recommended that two independent supplies be used. Disabling either VCO of the 'LS625 and 'LS627 can be achieved by removing the appropriate OSC V_{CC}. An enable input is provided on the 'LS624, 'LS626, 'LS628, and 'LS629. When the enable input is low, the output is enabled; when the enable input is high, the internal oscillator is disabled, Y is high, and Z is low. Caution! Crosstalk may occur in the dual devices ('LS625, 'LS626, 'LS627 and 'LS629) when both VCOs are operated simultaneously. To minimize crosstalk, either of the following are recommended: (A) If frequencies are widely separated, use a 10-μh inductor between V_{CC} pins. (B) If frequencies are closely spaced, use two separate V_{CC} supplies or place two series diodes between the V_{CC} pins.

The pulse-synchronization-gating section ensures that the first output pulse is neither clipped nor extended. The duty cycle of the square-wave output is fixed at approximately 50 percent.

The SN54LS624 thru SN54LS629 are characterized for operation over the full military temperature range of -55 °C to 125 °C. The SN74LS624 thru SN74LS629 are characterized for operation from 0 °C to 70 °C.

**SN54LS624 THRU SN54LS629,
SN74LS624 THRU SN74LS629
VOLTAGE-CONTROLLED OSCILLATORS**

**SN54LS624 . . . J OR W PACKAGE
SN74LS624 . . . D OR N PACKAGE
(TOP VIEW)**

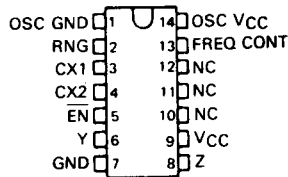

**SN54LS625 . . . J OR W PACKAGE
SN74LS625 . . . D OR N PACKAGE
(TOP VIEW)**

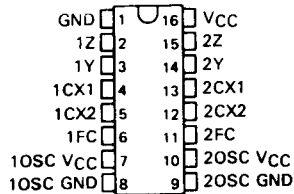

**SN54LS626 . . . J OR W PACKAGE
SN74LS626 . . . D OR N PACKAGE
(TOP VIEW)**

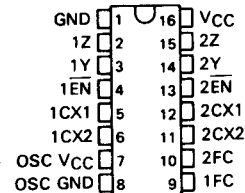

NC - No internal connection

**SN54LS624 . . . FK PACKAGE
(TOP VIEW)**

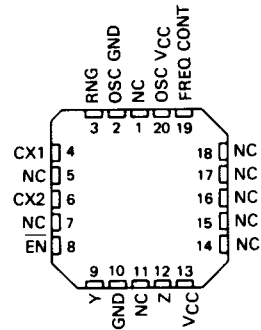

**SN54LS625 . . . FK PACKAGE
(TOP VIEW)**

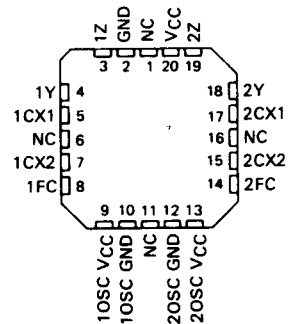

**SN54LS626 . . . FK PACKAGE
(TOP VIEW)**

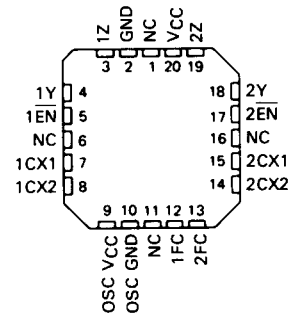

2

TTL Devices

**SN54LS624 THRU SN54LS629,
SN74LS624 THRU SN74LS629
VOLTAGE-CONTROLLED OSCILLATORS**

**SN54LS627 . . . J OR W PACKAGE
SN74LS627 . . . D OR N PACKAGE
(TOP VIEW)**

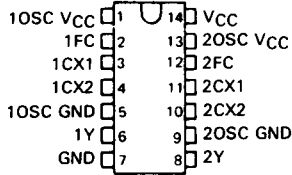

**SN54LS628 . . . J OR W PACKAGE
SN74LS628 . . . D OR N PACKAGE
(TOP VIEW)**

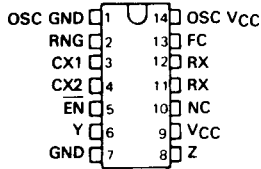

**SN54LS629 . . . J OR W PACKAGE
SN74LS629 . . . D OR N PACKAGE
(TOP VIEW)**

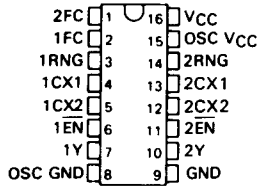

NC-No internal connection

**SN54LS627 . . . FK PACKAGE
(TOP VIEW)**

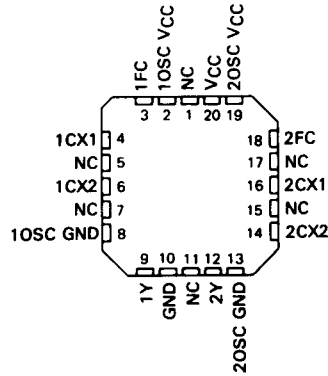

**SN54LS628 . . . FK PACKAGE
(TOP VIEW)**

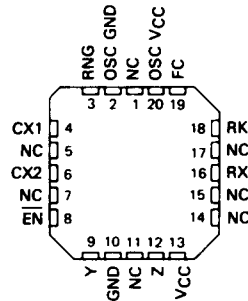

**SN54LS629 . . . FK PACKAGE
(TOP VIEW)**

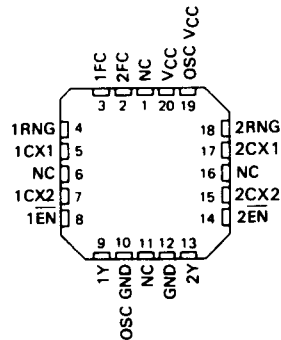

SN54LS624 THRU SN54LS629, SN74LS624 THRU SN74LS629 VOLTAGE-CONTROLLED OSCILLATORS

logic diagram (positive logic)

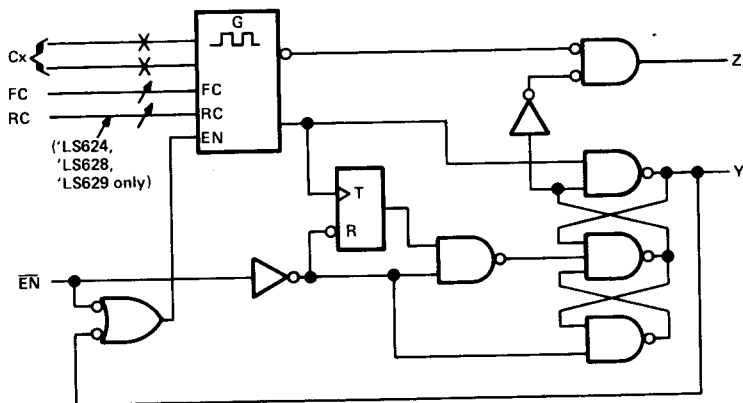

2

TTL Devices

logic symbols†

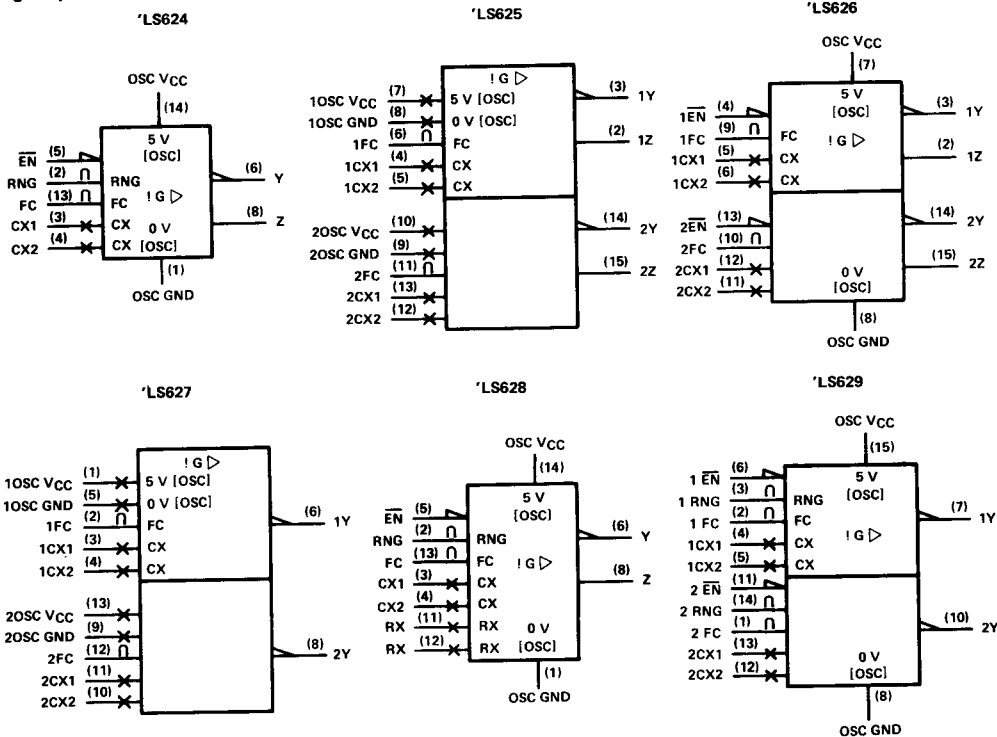

†These symbols are in accordance with ANSI/IEEE Std. 91-1984 and IEC Publication 617-12. Pin numbers shown are for D, J, N, and W packages.

**SN54LS624 THRU SN54LS629,
SN74LS624 THRU SN74LS629
VOLTAGE-CONTROLLED OSCILLATORS**

recommended operating conditions

	SN54LS'			SN74LS'			UNIT
	MIN	NOM	MAX	MIN	NOM	MAX	
Supply voltage, V_{CC}	4.5	5	5.5	4.75	5	5.25	V
Input voltage at frequency control or range input, $V_{I(freq)}$ or $V_{I(rng)}$ †	0		5	0		5	V
High-level output current, I_{OH}			-1.2			-1.2	mA
Low-level output current, I_{OL}			12			24	mA
Output frequency, f_o	1			1			Hz
Output frequency, f_o			20			20	MHz
Operating free-air temperature, T_A	-55		125	0		70	°C

electrical characteristics over recommended operating free-air temperature range (unless otherwise noted)

PARAMETER		TEST CONDITIONS†	SN54LS'			SN74LS'			UNIT	
			MIN	TYP‡	MAX	MIN	TYP‡	MAX		
V_{IH}	High-level input voltage at enable#		2			2			V	
V_{IL}	Low-level input voltage at enable#				0.7			0.8	V	
V_{IK}	Input clamp voltage at enable#	$V_{CC} = \text{MIN}, I_I = -18 \text{ mA}$			-1.5			-1.5	V	
V_{OH}	High-level output voltage	$V_{CC} = \text{MIN}, I_{OH} = -1.2 \text{ mA}, \text{EN at } V_{IL} \text{ max, See Note 3}$	2.5	3.4		2.7	3.4		V	
V_{OL}	Low-level output voltage	$V_{CC} = \text{MIN}, \text{EN at } V_{IL} \text{ max, See Note 3}$	$I_{OL} = 12 \text{ mA}$		0.25	0.4	0.25	0.4	V	
			$I_{OL} = 24 \text{ mA}$				0.35	0.5		
I_I	Input current	Freq control or range†	$V_{CC} = \text{MAX}$		$V_I = 5 \text{ V}$		$V_I = 5 \text{ V}$		μA	
			$V_{CC} = \text{MAX}$		$V_I = 1 \text{ V}$		$V_I = 1 \text{ V}$			
I_I	Input current at maximum input voltage	Enable#	$V_{CC} = \text{MAX}, V_I = 7 \text{ V}$			0.2			0.2	mA
I_{IH}	High-level input current	Enable#	$V_{CC} = \text{MAX}, V_I = 2.7 \text{ V}$			40			40	μA
I_{IL}	Low-level input current	Enable#	$V_{CC} = \text{MAX}, V_I = 0.4 \text{ V}$			-0.8			-0.8	mA
I_{OS}	Short-circuit output current§		$V_{CC} = \text{MAX}$			-40		-225		mA
I_{CC}	Supply current, total into V_{CC} and OSC V_{CC} pins		$V_{CC} = \text{MAX}, \text{Enable}^\# = 4.5 \text{ V}$ See Note 4	'LS624		20	35	20	35	mA
				'LS625		35	55	35	55	
				'LS626		35	55	35	55	
				'LS627		35	55	35	55	
				'LS628		20	35	20	35	
				'LS629		35	55	35	55	

†For conditions shown as MIN or MAX, use the appropriate value specified under recommended operating conditions.

‡All typical values are at $V_{CC} = 5 \text{ V}, T_A = 25^\circ\text{C}$.

§Not more than one output should be shorted at a time and duration of the short-circuit should not exceed one second.

¶The range input is provided only on the 'LS624, 'LS628, and 'LS629.

#The enable input is provided only on the 'LS624, 'LS626, 'LS628, and 'LS629.

NOTES: 3. V_{OH} for Y outputs and V_{OL} for Z outputs are measured while enable inputs are at $V_{IL} \text{ MAX}$, with individual 1-k Ω resistors connected from CX1 to V_{CC} and from CX2 to ground. The resistor connections are reversed for testing V_{OH} for Z outputs and V_{OL} for Y inputs.

4. For 'LS624, 'LS626, 'LS628, and 'LS629, I_{CC} is measured with the outputs disabled and open. For 'LS625 and 'LS627, I_{CC} is measured with one OSC $V_{CC} = \text{MAX}$, and with the other OSC V_{CC} and outputs open.

2

TTL Devices

SN54LS624 THRU SN54LS629, SN74LS624 THRU SN74LS629 VOLTAGE-CONTROLLED OSCILLATORS

switching characteristics, $V_{CC} = 5\text{ V}$ (unless otherwise noted), $R_L = 667\ \Omega$, $C_L = 45\text{ pF}$, $T_A = 25^\circ\text{C}$

PARAMETER	TEST CONDITIONS	'LS624, 'LS628, 'LS629			'LS625, 'LS626, 'LS627			UNIT	
		MIN	TYP	MAX	MIN	TYP	MAX		
f_o Output frequency	$C_{ext} = 50\text{ pF}$	$V_{I(freq)} = 5\text{ V}, V_{I(rng)} = 0\text{ V}$	15	20	25			MHz	
		$V_{I(freq)} = 1\text{ V}, V_{I(rng)} = 5\text{ V}$	1.1	1.6	2.1				
		$V_{I(freq)} = 5\text{ V}$				7	9.5		12
		$V_{I(freq)} = 0\text{ V}$				0.9	1.2		1.5

TYPICAL CHARACTERISTICS

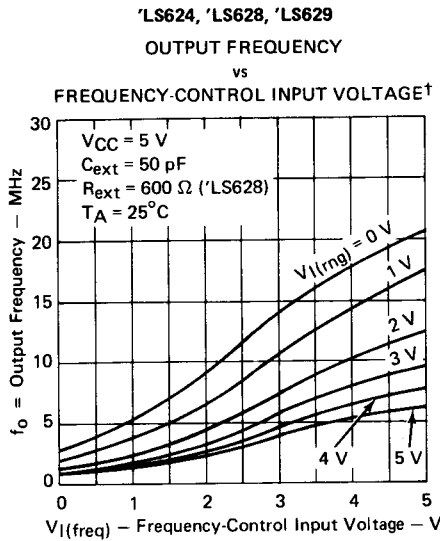

FIGURE 1

† Due to the effects of stray capacitance the output frequency may be unstable when the frequency control voltage is less than 1 volt.

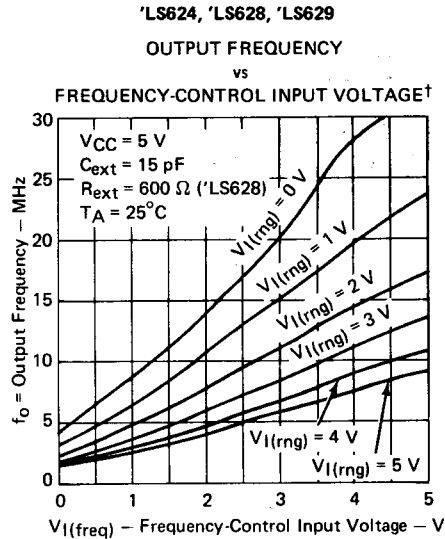

FIGURE 2

2

TTL Devices

**SN54LS624 THRU SN54LS629,
SN74LS624 THRU SN74LS629
VOLTAGE-CONTROLLED OSCILLATORS**

TYPICAL CHARACTERISTICS

'LS624, 'LS628, 'LS629

OUTPUT FREQUENCY

vs

EXTERNAL CAPACITANCE

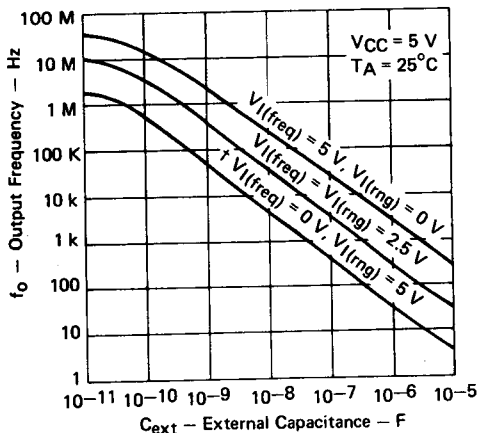

FIGURE 3

'LS625, 'LS626, 'LS627

OUTPUT FREQUENCY

vs

FREQUENCY-CONTROL INPUT VOLTAGE

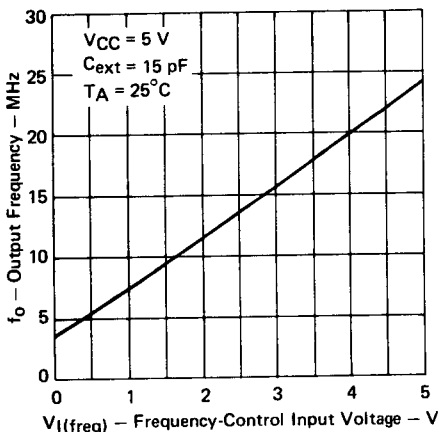

FIGURE 5

'LS625, 'LS626, 'LS627

OUTPUT FREQUENCY

vs

FREQUENCY-CONTROL INPUT VOLTAGE †

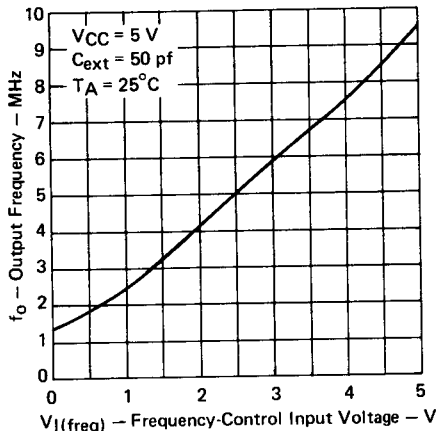

FIGURE 4

'LS625, 'LS626, 'LS627

OUTPUT FREQUENCY

vs

EXTERNAL CAPACITANCE

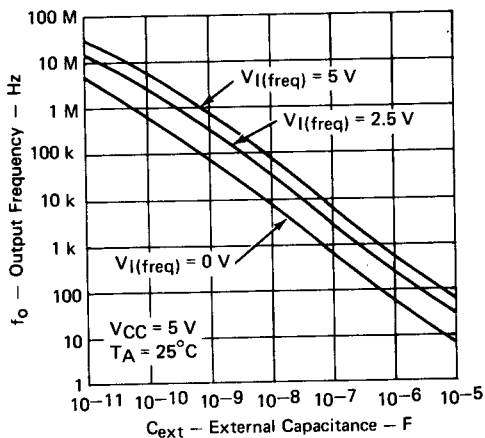

FIGURE 6

† Due to the effects of stray capacitance the output frequency may be unstable when the frequency control voltage is less than 1 volt.

2

TTL Devices

**SN54LS624 THRU SN54LS629,
SN74LS624 THRU SN74LS629
VOLTAGE-CONTROLLED OSCILLATORS**

TYPICAL CHARACTERISTICS

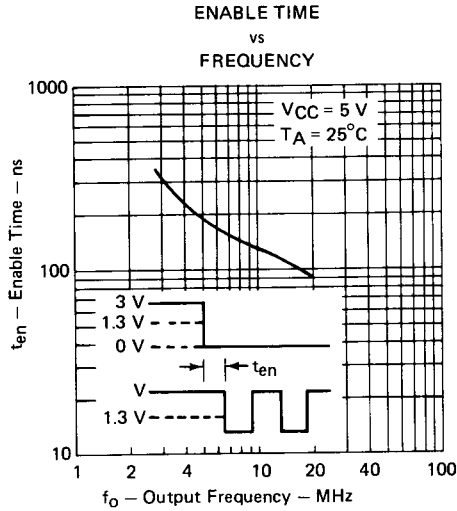
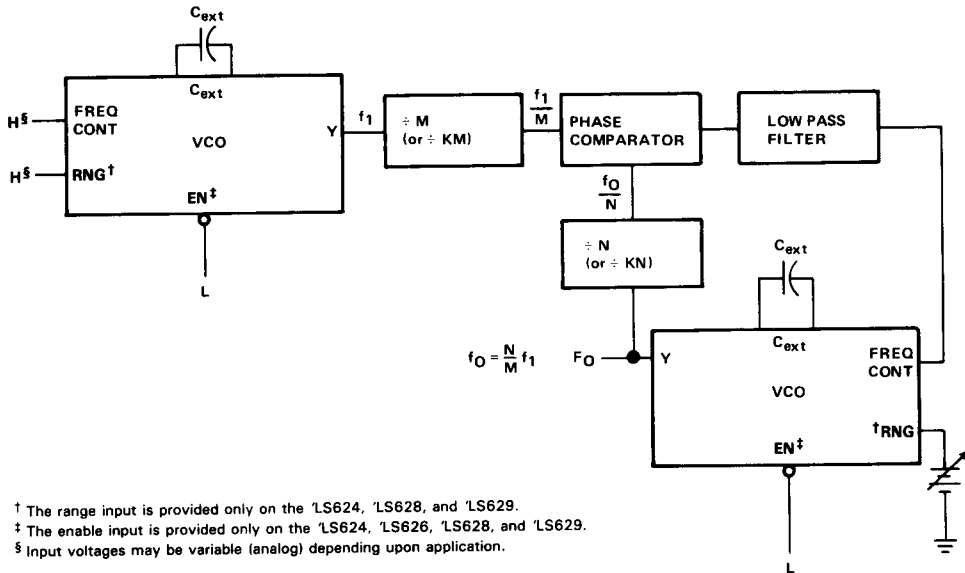

FIGURE 7

2
TTL Devices

TYPICAL APPLICATIONS DATA



† The range input is provided only on the 'LS624, 'LS628, and 'LS629.
‡ The enable input is provided only on the 'LS624, 'LS626, 'LS628, and 'LS629.
§ Input voltages may be variable (analog) depending upon application.

FIGURE A—PHASE-LOCKED LOOP