



Features

- 6A Output Current
- Input Voltage Range:
3.1 V to 5.5 V
- 90% Efficiency
- Adjustable Output Voltage
- Standby Function
- Short Circuit Protection
- Small Footprint (0.61 in²)
- Solderable Copper Case
- 8.8 10⁶ Hours MTBF

Description

The PT6440 Excalibur™ power modules are a series of high performance Integrated Switching Regulators (ISRs), housed in a thermally efficient solderable copper case. These modules operate from input voltages as low as 3.1V to produce a high-output low-voltage power source; ideal for powering the industry's latest DSP and microprocessors. The series includes standard output bus voltages as low as 1.0VDC.

The innovative copper case construction provides superior thermal performance in a small footprint. Both through-hole and surface mount pin configurations are available. The PT6440 series operating features include external output voltage adjustment, an On/Off inhibit, and short-circuit protection. A 100µF input, and 330µF output capacitor are required for proper operation.

Ordering Information

- PT6441□ = 3.3 Volts
 † PT6442□ = 2.5 Volts
 † PT6443□ = 2.0 Volts
 † PT6444□ = 1.8 Volts
 † PT6445□ = 1.5 Volts
 † PT6446□ = 1.2 Volts
 † PT6447□ = 1.0 Volts

† 3.3V Input Bus Capable

PT Series Suffix (PT1234x)

Case/Pin Configuration	Order Suffix	Package Code *
Vertical	N	(EPH)
Horizontal	A	(EPJ)
SMD	C	(EPK)

* Previously known as package styles 1540/50.
 (Reference the applicable package code drawing for the dimensions and PC board layout)

Pin-Out Information

Pin	Function
1	Inhibit *
2	V _{in}
3	V _{in}
4	V _{in}
5	GND
6	GND
7	GND
8	GND
9	V _{out}
10	V _{out}
11	V _{out}
12	V _{out} Adj *

* For further information, see application notes.

Standard Application

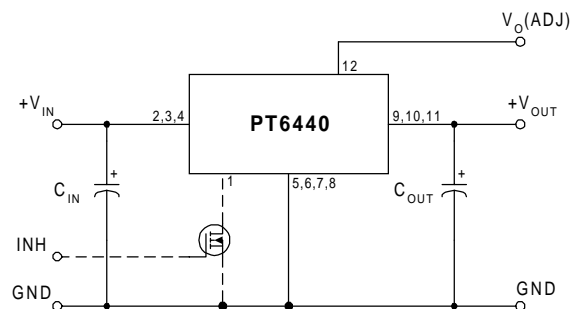

C_{in} = Required 100µF electrolytic
 C_{out} = Required 330µF electrolytic

PT6440 Series

6-A 5-V/3.3-V Input Adjustable Integrated Switching Regulator

Specifications (Unless otherwise stated, $T_a = 25^\circ\text{C}$, $V_{in} = 5\text{V}$, $C_{in} = 100\mu\text{F}$, $C_{out} = 330\mu\text{F}$, and $I_o = I_{o,max}$)

Characteristic	Symbol	Conditions	PT6440 SERIES			Units	
			Min	Typ	Max		
Output Current	I_o	$T_a = +60^\circ\text{C}$, 200LFM $T_a = +25^\circ\text{C}$, natural convection	0.1 (1) 0.1 (1)	— —	6 6	A	
Input Voltage Range	V_{in}	Over I_o Range	$V_o = 3.3\text{V}$ $V_o \leq 2.5\text{V}$	4.5 3.1	— —	5.5 5.5	VDC
Set Point Voltage Tolerance	V_o, tol		—	± 1	± 2 (2)	$\%V_o$	
Temperature Variation	Reg_{temp}	$-40^\circ \leq T_a \leq +85^\circ\text{C}$, $I_o = I_{o,min}$	—	± 0.5	—	$\%V_o$	
Line Regulation	Reg_{line}	Over V_{in} range	—	± 6	± 10	mV	
Load Regulation	Reg_{load}	Over I_o range	—	± 10	± 25	mV	
Total Output Voltage Variation	$\Delta V_{o,tot}$	Includes set-point, line, load, $-40^\circ \leq T_a \leq +85^\circ\text{C}$	—	± 2	± 3	$\%V_o$	
Efficiency	η	$I_o = 4\text{A}$	$V_o = 3.3\text{V}$ $V_o = 2.5\text{V}$ $V_o = 2.0\text{V}$ $V_o = 1.8\text{V}$ $V_o = 1.5\text{V}$ $V_o = 1.2\text{V}$ $V_o = 1.0\text{V}$	— — — — — — —	91 89 85 85 81 80 78	— — — — — — —	%
V_o Ripple (pk-pk)	V_r	20MHz bandwidth	—	20	—	mV_{pp}	
Transient Response	t_{tr}	$5\text{A}/\mu\text{s}$ load step, 50% to 100% $I_{o,max}$	—	50	—	μs	
	ΔV_{tr}	V_o over/undershoot	—	± 70	—	mV	
Short Circuit Threshold	I_{sc} threshold		—	10	—	A	
Switching Frequency	f_s	Over V_{in} and I_o range	300	350	400	kHz	
Inhibit (Pin 1)		Referenced to $-V_{in}$ (pin 8)					
Input High Voltage	V_{IH}		$V_{in} - 0.5$	—	Open (2)	V	
Input Low Voltage	V_{IL}		-0.2	—	$+0.5$		
Input Low Current	I_{IL}		—	-0.5	—	mA	
Standby Input Current	$I_{in, standby}$	pins 1 & 5 connected	—	$+0.5$	—	mA	
External Output Capacitance	C_{out}	See application schematic	330	—	1,000	μF	
External Input Capacitance	C_{in}	See application schematic	100	—	—	μF	
Operating Temperature Range	T_a	Over V_{in} range	-40 (3)	—	$+85$ (4)	$^\circ\text{C}$	
Storage Temperature	T_s	—	-40	—	$+125$	$^\circ\text{C}$	
Reliability	MTBF	Per Bellcore TR-332 50% stress, $T_a = 40^\circ\text{C}$, ground benign	8.8	—	—	10^6 Hrs	
Mechanical Shock	—	Per Mil-Std-883D, method 2002.3, 1ms, half-sine, mounted to a fixture	—	500	—	G's	
Mechanical Vibration	—	Mil-Std-883D, Method 2007.2, 20-2000Hz, soldered in PCB	—	20 (5)	—	G's	
Weight	—		—	23	—	grams	
Flammability	—	Materials meet UL 94V-0					

Notes: (1) The ISR will operate at no load with reduced specifications.

(2) The Inhibit control (pin 1) has an internal pull-up and if it is left open circuit the module will operate when input power is applied. The open-circuit voltage is the input voltage V_{in} . Use a discrete MOSFET to control the Inhibit pin, and ensure a transition time of less than $\leq 10\mu\text{s}$. Consult the related application note for other interface considerations.

(3) For operation below 0°C , C_{in} and C_{out} must have stable characteristics. Use either low ESR tantalum or Oscon® capacitors.

(4) See Safe Operating Area curves or contact the factory for the appropriate derating.

(5) The case pins on through-hole package types (suffixes N & A) must be soldered. For more information consult the applicable package outline drawing.

Input/Output Capacitors: The PT6440 regulator series requires a $100\mu\text{F}$ electrolytic (or tantalum) capacitor at the input and $330\mu\text{F}$ at the output for proper operation in all applications. In addition, the input capacitance, C_{in} , must be rated for a minimum of 350mA rms of ripple current, and the ESR of the output capacitor, C_{out} , must be less than $100\text{m}\Omega$ @ 100kHz . For transient or dynamic load applications additional output capacitance may be necessary. For more information consult the related application note on capacitor recommendations.

6-A 5-V/3.3-V Input Adjustable
Integrated Switching Regulator

PT6440 Series Performance; @ $V_{IN} = 5.0V$ (See Note A)

PT6440 Series Performance; @ $V_{IN} = 3.3V$ (See Note A)

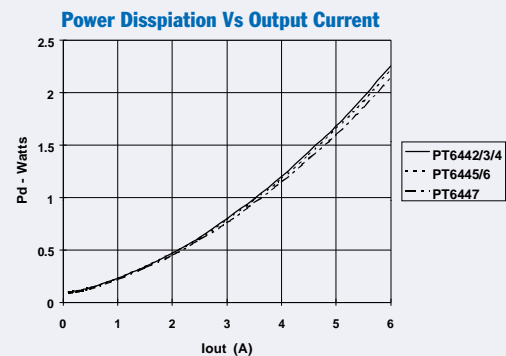
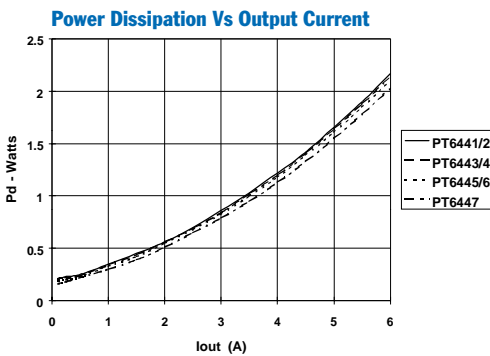
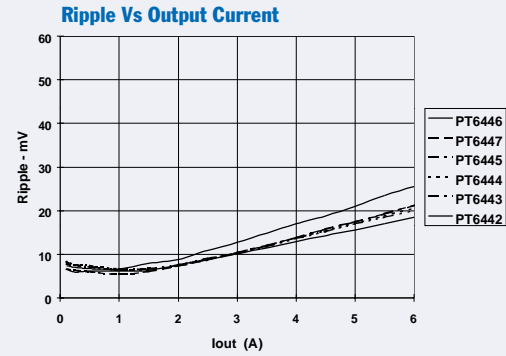
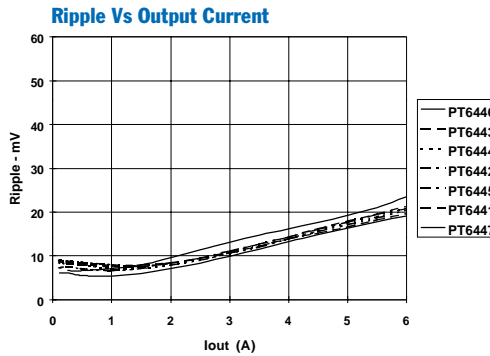
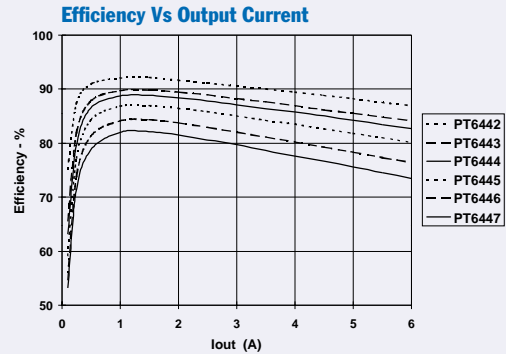
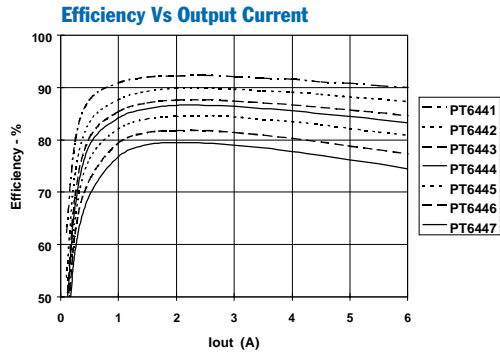

Safe Operating Area Curves (See Note B)

PT6440 Series, $V_{IN} = 5.0V$

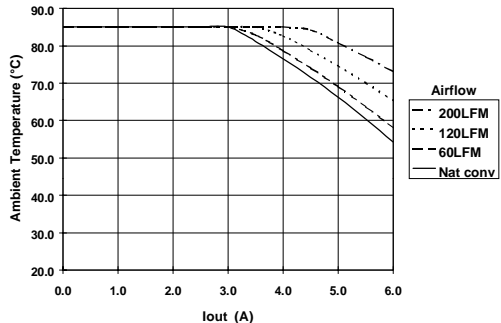

Safe Operating Area Curves (See Note B)

PT6440 Series, $V_{IN} = 3.3V$

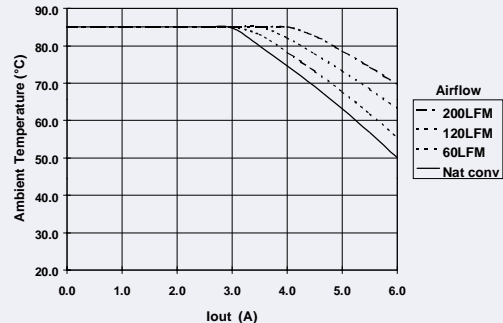

Note A: Characteristic data has been developed from actual products tested at 25°C. This data is considered typical data for the Converter.

Note B: SOA curves represent the conditions at which internal components are at or below the manufacturer's maximum operating temperatures

Capacitor Recommendations for the PT6440 Excalibur™ 5V/3.3V Bus Step-Down ISRs

Input Capacitors

The recommended input capacitance is determined by 350 milli-amperes (rms) minimum ripple current rating and 100µF minimum capacitance. Capacitors placed at the input must be rated for a minimum of twice the input voltage with +5V operation. Ripple current and $\leq 200\text{m}\Omega$ Equivalent Series Resistance (ESR) values are the major considerations, along with temperature, when selecting the proper input capacitor.

Output Capacitors

The ESR of the required 330µF output capacitor must be less than or equal to 100mΩ. Failure to observe this requirement may lead to regulator instability or oscillation. Electrolytic capacitors have poor ripple performance at frequencies greater than 300kHz but excellent low frequency transient response. Above the ripple frequency, ceramic decoupling capacitors are necessary to improve the transient response and reduce any high frequency noise components apparent during higher current excursions. The preferred low ESR type capacitor part numbers are identified in Table 1.

Tantalum Capacitors

Tantalum capacitors are recommended on the output bus but only the AVX TPS series, Sprague 593D/594/595 series or Kemet T495/T510 series. These capacitors are specified over many other types due to their higher surge current, power dissipation and ripple current capability. As a caution, the TAJ Series by AVX is not recommended. This series exhibits considerably higher ESR and lower ripple current capability. The TAJ series is also less reliable than the TPS series when determining power dissipation capability. Tantalum or Oscon® types are recommended in applications where ambient temperatures fall below 0°C.

Capacitor Table

Table 1 identifies vendors with acceptable ESR and maximum allowable ripple current (rms) ratings. The suggested minimum quantities per regulator for both the input and output buses are identified.

This is not an extensive capacitor list. Capacitors from other vendors are available with comparable specifications. Those listed are for guidance. The RMS ripple current rating and ESR (Equivalent Series Resistance at 100kHz) are critical parameters necessary to insure both optimum regulator performance and long capacitor life.

Table 1; Input/Output Capacitors

Capacitor Vendor/ Component Series	Capacitor Characteristics					Quantity		Vendor Number
	Working Voltage	Value(µF)	(ESR) Equivalent Series Resistance	85°C Maximum Ripple Current(Irms)	Physical Size(mm)	Input Bus	Output Bus	
Panasonic, FC (Radial)	35V	390µF	0.065Ω	1205mA	12.5×15	1	1	EEUFC1V391S
	35V	100µF	0.117Ω	555mA	8×11.5	1	N/R	EEUFC1V101
	25V	330µF	0.090Ω	755mA	10×12.5	1	1	EEUFC1E331
FC (Surface Mount)	16V	220µF	0.15Ω±2	670mA	10×10.2	1	2	EEVFC1C221P
	25V	100µF	0.40Ω	450mA	8×10.2	1	N/R	EEVFC1101P
	35V	330µF	0.065Ω	1205mA	12×16.5	1	1	EEVFC1V471LQ
United Chemi-Con LXV/LXZ	25V	330µF	0.084Ω	825mA	10×16	1	1	LXV25VB331M10X16LL
	35V	220µF	0.090Ω±2	760mA	10×12.5	1	2	LXZ35VB221M10X12LL
FS	10V	330µF	0.025Ω	3500mA	10×10.5	1	1	10FS330M
	10V	100µF	0.040Ω	2100mA	6.3×9.8	1	N/R	10FS100M
Nichicon, PL (Radial)	35V	330µF	0.065Ω	1020mA	12.5×15	1	1	UPL1V331MHH6
UD (Surface Mount)	35V	330µF	0.090Ω	670mA	10×10	1	1	UUD1V331MNR1GS
	35V	220µF	0.17Ω±2	450mA	8×10	1	2	UUD1V2211MNR1GS
Oscon, SS (Radial)	10V	330µF	0.025Ω	>3500mA	10×10.5	1	1	10SS330M
SV (Surface Mount)	10V	330µF	0.025Ω	>3800mA	10.3×10.3	1	1	10SV300M
	16V	100µF	0.045Ω	2200mA	10.3×10.3	1	N/R	16SV100M
AVX Tantalum TPS	10V	330µF	0.100Ω	1414mA	7.3L	1	1	TPSV337M010R0100
	10V	330µF	0.060Ω	1826mA	<4.3W	1	1	TPSV337M010R0060
	10V	150µF	0.100Ω	1095mA	<4.1H	1	2	TPSD107M010R100
Kemet, T510 T495	10V	330µF	0.033Ω	1400mA	7.3L ×5.7W	1	1	T510X337M010AS
	10V	220µF	0.070Ω±2	>2000mA	<4.0H	1	2	T495X227M010AS
Sprague 594D	10V	330µF	0.045Ω	2350mA	7.3L ×6W	1	1	594D337X0010R2T
	10V	150µF	0.090Ω	1100mA	<4.1H	1	2	594D157X0010C2T

Adjusting the Output Voltage of the PT6440 Excalibur™ 5V/3.3V Bus Step-Down ISRs

The output voltage of the PT6440 Series ISRs may be adjusted higher or lower than the factory trimmed pre-set voltage with the addition of a single external resistor. Table 1 gives the allowable adjustment range for each model for either series as V_a (min) and V_a (max).

Adjust Up: An increase in the output voltage is obtained by adding a resistor R_2 , between V_o Adj (pin 12) and GND (pins 5–8).

Adjust Down: Add a resistor (R_1), between V_o Adj (pin 12) and V_{out} (pins 9–11).

The values of (R_1) [adjust down], and R_2 [adjust up], can also be calculated using the following formulas. Refer to Figure 1 and Table 2 for both the placement and value of the required resistor; either (R_1) or R_2 as appropriate.

$$(R_1) = \frac{R_o (V_a - 0.9)}{V_o - V_a} - R_s \quad \text{k}\Omega$$

$$R_2 = \frac{0.9 R_o}{V_a - V_o} - R_s \quad \text{k}\Omega$$

Where: V_o = Original output voltage
 V_a = Adjusted output voltage
 R_o = The resistance value from Table 1
 R_s = The series resistance from Table 1

Figure 1

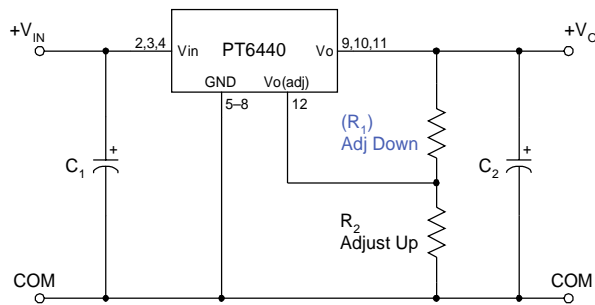

Notes:

1. Use only a single 1% resistor in either the (R_1) or R_2 location. Place the resistor as close to the ISR as possible.
2. Never connect capacitors from V_o adj to either GND or V_{out} . Any capacitance added to the V_o adjust pin will affect the stability of the ISR.
3. For each model, adjustments to the output voltage may place additional limits on the minimum input voltage. The revised minimum input voltage must comply with the following requirement.

$$V_{in}(\text{min}) = (V_a + 0.5)V \text{ or as specified in the data sheet, whichever is greater.}$$

Table 1

ISR ADJUSTMENT RANGE AND FORMULA PARAMETERS							
Series Pt. #	PT6441	PT6442	PT6443	PT6444	PT6445	PT6446	PT6447
V_o (nom)	3.3	2.5	2.0	1.8	1.5	1.2	1.0
V_a (min)	2.88	1.97	1.64	1.5	1.3	1.08	0.97
V_a (max)	3.5	2.95	2.45	2.25	1.95	1.65	1.45
R_o (k Ω)	10.0	10.0	10.0	10.0	10.0	10.0	10.2
R_s (k Ω)	49.9	20.0	20.0	20.0	20.0	20.0	20.0

PT6440 Series

Table 2

ISR ADJUSTMENT RESISTOR VALUES

Series Pt. #	PT6441	PT6442	PT6443	PT6444	PT6445	PT6446	PT6447
V _o (nom)	3.3	2.5	2.0	1.8	1.5	1.2	1.0
V _a (req.d)							
0.97							(0.4)kΩ
1.0							
1.05							164.0kΩ
1.1						(0.0)kΩ	71.8kΩ
1.15						(30.0)kΩ	41.2kΩ
1.2							25.9kΩ
1.25						160.0kΩ	16.7kΩ
1.3					(0.0)kΩ	70.0kΩ	10.6kΩ
1.35					(10.0)kΩ	40.0kΩ	6.2kΩ
1.4					(30.0)kΩ	25.0kΩ	3.0kΩ
1.45					(90.0)kΩ	16.0kΩ	0.4kΩ
1.5				(0.0)kΩ		10.0kΩ	
1.55				(6.0)kΩ	160.0kΩ	5.7kΩ	
1.6				(15.0)kΩ	70.0kΩ	2.5kΩ	
1.65			(1.4)kΩ	(30.0)kΩ	40.0kΩ	0.0kΩ	
1.7			(6.7)kΩ	(60.0)kΩ	25.0kΩ		
1.75			(14.0)kΩ	(150.0)kΩ	16.0kΩ		
1.8			(25.0)kΩ		10.0kΩ		
1.85			(43.3)kΩ	160.0kΩ	5.7kΩ		
1.9			(80.0)kΩ	70.0kΩ	2.5kΩ		
1.95			(190.0)kΩ	40.0kΩ	0.0kΩ		
2.0		(2.0)kΩ		25.0kΩ			
2.05		(5.6)kΩ	160.0kΩ	16.0kΩ			
2.1		(10.0)kΩ	70.0kΩ	10.0kΩ			
2.15		(15.7)kΩ	40.0kΩ	5.7kΩ			
2.2		(23.3)kΩ	25.0kΩ	2.5kΩ			
2.25		(34.0)kΩ	16.0kΩ	0.0kΩ			
2.3		(50.0)kΩ	10.0kΩ				
2.35		(76.7)kΩ	5.7kΩ				
2.4		(130.0)kΩ	2.5kΩ				
2.45		(284.0)kΩ	0.0kΩ				
2.5							
2.55		160.0kΩ					
2.6		70.0kΩ					
2.65		40.0kΩ					
2.7		25.0kΩ					
2.75		16.0kΩ					
2.8		10.0kΩ					
2.85		5.7kΩ					
2.9	(0.0)kΩ	2.5kΩ					
2.95	(8.5)kΩ	0.0kΩ					
3.0	(20.1)kΩ						
3.05	(36.1)kΩ						
3.1	(60.1)kΩ						
3.15	(100.0)kΩ						
3.2	(180.0)kΩ						
3.25	(420.0)kΩ						
3.3							
3.35	130.0kΩ						
3.4	40.1kΩ						
3.45	10.1kΩ						
3.48	0.0kΩ						

R1 = (Blue) R2 = Black

Using the Inhibit Function on the PT6440 Excalibur™ 5V/3.3V Bus Step-Down ISRs

For applications requiring output voltage On/Off control, the 12-pin PT6440 series products incorporate an *Inhibit* function. This function may be used wherever there is a requirement for the module to be switched off. The function is provided by the *Inhibit* control (pin 1) input.

The ISR functions normally with pin 1 open-circuit, ¹ providing a regulated output whenever a valid source voltage is applied to V_{in} , (pins 2–4), with respect to GND (pins 5–8). When a low-level ground signal is applied to pin 1, the regulator output is disabled.

Figure 1 shows an application schematic, which details the typical use of the Inhibit function. Note the discrete transistor (Q_1). The Inhibit control has its own internal pull-up to $+V_{in}$ potential. An open-collector or open-drain device is required to control this pin. ²

The Inhibit pin control thresholds are given in Table 1. Equation 1 may be used to determine the approximate current drawn from the input source, and by Q_1 when the regulator is placed in the inhibit state.

Table 1; Inhibit Control Requirements ³

Parameter	Min	Max
Enable (V_{IH})	$V_{in} - 0.5$	V_{in}
Disable (V_{IL})	-0.2V	0.5V
Transition Time	10 μ s ⁴	

Equation 1; Off Input Current

$$I_{stby} = V_{in} \div 10k\Omega \pm 20\%$$

Figure 1

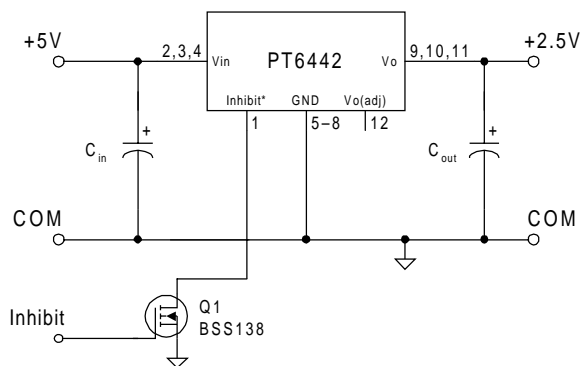

Turn-On Time: In the circuit of Figure 1, turning Q_1 on applies a low-voltage to the *Inhibit* control (pin 1) and disables the regulator output. Correspondingly, turning Q_1 off allows the *Inhibit* control pin to be pulled high by its internal pull-up resistor. The ISR produces a fully regulated output voltage within 10 milliseconds of the release of the Inhibit control pin. The actual turn-on time will vary with input voltage, output load, and the total amount of load capacitance. Figure 2 shows the typical rise in both output voltage and input current for a PT6441 (3.3V) following the turn-off of Q_1 at time $t = 0$. The waveform was measured with a 5Vdc input voltage, and 6 Adc resistive load.

Figure 2

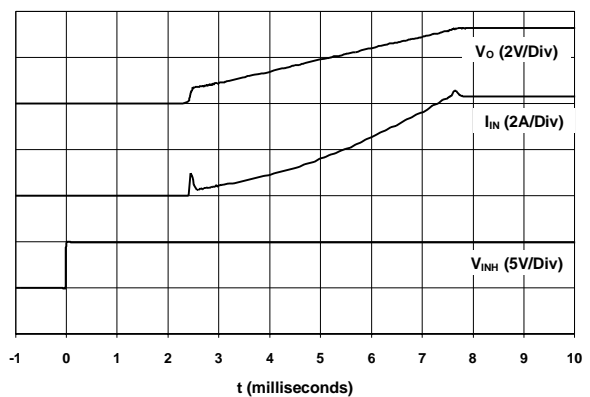

Notes:

1. Use an open-collector device (preferably a discrete transistor) for the Inhibit input. A pull-up resistor is not necessary. To disable the output voltage, the control pin should be pulled low to less than +0.5VDC.
2. Do not control the Inhibit input with an external DC voltage. This will lead to erratic operation of the ISR and may over-stress the regulator.
3. Avoid capacitance greater than 500pF at the Inhibit control pin. Excessive capacitance at this pin will cause the ISR to produce a pulse on the output voltage bus at turn-on.
4. Keep the On/Off transition to less than 10 μ s. This prevents erratic operation of the ISR, which could cause the output voltage to be momentarily higher than normal.

PACKAGING INFORMATION

Orderable Device	Status (1)	Package Type	Package Drawing	Pins	Package Qty	Eco Plan (2)	Lead/Ball Finish (6)	MSL Peak Temp (3)	Op Temp (°C)	Device Marking (4/5)	Samples
PT6441N	OBSOLETE	SIP MODULE	EPH	12		TBD	Call TI	Call TI	-40 to 85		
PT6443C	LIFEBUY	SIP MODULE	EPK	12		TBD	Call TI	Call TI	-40 to 85		
PT6443N	NRND	SIP MODULE	EPH	12		TBD	Call TI	Call TI	-40 to 85		
PT6444A	OBSOLETE	SIP MODULE	EPJ	12		TBD	Call TI	Call TI	-40 to 85		
PT6446A	LIFEBUY	SIP MODULE	EPJ	12		TBD	Call TI	Call TI	-40 to 85		
PT6446N	LIFEBUY	SIP MODULE	EPH	12		TBD	Call TI	Call TI	-40 to 85		
PT6447A	NRND	SIP MODULE	EPJ	12		TBD	Call TI	Call TI	-40 to 85		
PT6447C	NRND	SIP MODULE	EPK	12		TBD	Call TI	Call TI	-40 to 85		
PT6447N	NRND	SIP MODULE	EPH	12		TBD	Call TI	Call TI	-40 to 85		

(1) The marketing status values are defined as follows:

ACTIVE: Product device recommended for new designs.

LIFEBUY: TI has announced that the device will be discontinued, and a lifetime-buy period is in effect.

NRND: Not recommended for new designs. Device is in production to support existing customers, but TI does not recommend using this part in a new design.

PREVIEW: Device has been announced but is not in production. Samples may or may not be available.

OBSOLETE: TI has discontinued the production of the device.

(2) Eco Plan - The planned eco-friendly classification: Pb-Free (RoHS), Pb-Free (RoHS Exempt), or Green (RoHS & no Sb/Br) - please check <http://www.ti.com/productcontent> for the latest availability information and additional product content details.

TBD: The Pb-Free/Green conversion plan has not been defined.

Pb-Free (RoHS): TI's terms "Lead-Free" or "Pb-Free" mean semiconductor products that are compatible with the current RoHS requirements for all 6 substances, including the requirement that lead not exceed 0.1% by weight in homogeneous materials. Where designed to be soldered at high temperatures, TI Pb-Free products are suitable for use in specified lead-free processes.

Pb-Free (RoHS Exempt): This component has a RoHS exemption for either 1) lead-based flip-chip solder bumps used between the die and package, or 2) lead-based die adhesive used between the die and leadframe. The component is otherwise considered Pb-Free (RoHS compatible) as defined above.

Green (RoHS & no Sb/Br): TI defines "Green" to mean Pb-Free (RoHS compatible), and free of Bromine (Br) and Antimony (Sb) based flame retardants (Br or Sb do not exceed 0.1% by weight in homogeneous material)

(3) MSL, Peak Temp. - The Moisture Sensitivity Level rating according to the JEDEC industry standard classifications, and peak solder temperature.

(4) There may be additional marking, which relates to the logo, the lot trace code information, or the environmental category on the device.

(5) Multiple Device Markings will be inside parentheses. Only one Device Marking contained in parentheses and separated by a "~" will appear on a device. If a line is indented then it is a continuation of the previous line and the two combined represent the entire Device Marking for that device.

⁽⁶⁾ Lead/Ball Finish - Orderable Devices may have multiple material finish options. Finish options are separated by a vertical ruled line. Lead/Ball Finish values may wrap to two lines if the finish value exceeds the maximum column width.

Important Information and Disclaimer:The information provided on this page represents TI's knowledge and belief as of the date that it is provided. TI bases its knowledge and belief on information provided by third parties, and makes no representation or warranty as to the accuracy of such information. Efforts are underway to better integrate information from third parties. TI has taken and continues to take reasonable steps to provide representative and accurate information but may not have conducted destructive testing or chemical analysis on incoming materials and chemicals. TI and TI suppliers consider certain information to be proprietary, and thus CAS numbers and other limited information may not be available for release.

In no event shall TI's liability arising out of such information exceed the total purchase price of the TI part(s) at issue in this document sold by TI to Customer on an annual basis.

IMPORTANT NOTICE

Texas Instruments Incorporated and its subsidiaries (TI) reserve the right to make corrections, enhancements, improvements and other changes to its semiconductor products and services per JESD46, latest issue, and to discontinue any product or service per JESD48, latest issue. Buyers should obtain the latest relevant information before placing orders and should verify that such information is current and complete. All semiconductor products (also referred to herein as "components") are sold subject to TI's terms and conditions of sale supplied at the time of order acknowledgment.

TI warrants performance of its components to the specifications applicable at the time of sale, in accordance with the warranty in TI's terms and conditions of sale of semiconductor products. Testing and other quality control techniques are used to the extent TI deems necessary to support this warranty. Except where mandated by applicable law, testing of all parameters of each component is not necessarily performed.

TI assumes no liability for applications assistance or the design of Buyers' products. Buyers are responsible for their products and applications using TI components. To minimize the risks associated with Buyers' products and applications, Buyers should provide adequate design and operating safeguards.

TI does not warrant or represent that any license, either express or implied, is granted under any patent right, copyright, mask work right, or other intellectual property right relating to any combination, machine, or process in which TI components or services are used. Information published by TI regarding third-party products or services does not constitute a license to use such products or services or a warranty or endorsement thereof. Use of such information may require a license from a third party under the patents or other intellectual property of the third party, or a license from TI under the patents or other intellectual property of TI.

Reproduction of significant portions of TI information in TI data books or data sheets is permissible only if reproduction is without alteration and is accompanied by all associated warranties, conditions, limitations, and notices. TI is not responsible or liable for such altered documentation. Information of third parties may be subject to additional restrictions.

Resale of TI components or services with statements different from or beyond the parameters stated by TI for that component or service voids all express and any implied warranties for the associated TI component or service and is an unfair and deceptive business practice. TI is not responsible or liable for any such statements.

Buyer acknowledges and agrees that it is solely responsible for compliance with all legal, regulatory and safety-related requirements concerning its products, and any use of TI components in its applications, notwithstanding any applications-related information or support that may be provided by TI. Buyer represents and agrees that it has all the necessary expertise to create and implement safeguards which anticipate dangerous consequences of failures, monitor failures and their consequences, lessen the likelihood of failures that might cause harm and take appropriate remedial actions. Buyer will fully indemnify TI and its representatives against any damages arising out of the use of any TI components in safety-critical applications.

In some cases, TI components may be promoted specifically to facilitate safety-related applications. With such components, TI's goal is to help enable customers to design and create their own end-product solutions that meet applicable functional safety standards and requirements. Nonetheless, such components are subject to these terms.

No TI components are authorized for use in FDA Class III (or similar life-critical medical equipment) unless authorized officers of the parties have executed a special agreement specifically governing such use.

Only those TI components which TI has specifically designated as military grade or "enhanced plastic" are designed and intended for use in military/aerospace applications or environments. Buyer acknowledges and agrees that any military or aerospace use of TI components which have **not** been so designated is solely at the Buyer's risk, and that Buyer is solely responsible for compliance with all legal and regulatory requirements in connection with such use.

TI has specifically designated certain components as meeting ISO/TS16949 requirements, mainly for automotive use. In any case of use of non-designated products, TI will not be responsible for any failure to meet ISO/TS16949.

Products

Audio	www.ti.com/audio
Amplifiers	amplifier.ti.com
Data Converters	dataconverter.ti.com
DLP® Products	www.dlp.com
DSP	dsp.ti.com
Clocks and Timers	www.ti.com/clocks
Interface	interface.ti.com
Logic	logic.ti.com
Power Mgmt	power.ti.com
Microcontrollers	microcontroller.ti.com
RFID	www.ti-rfid.com
OMAP Applications Processors	www.ti.com/omap
Wireless Connectivity	www.ti.com/wirelessconnectivity

Applications

Automotive and Transportation	www.ti.com/automotive
Communications and Telecom	www.ti.com/communications
Computers and Peripherals	www.ti.com/computers
Consumer Electronics	www.ti.com/consumer-apps
Energy and Lighting	www.ti.com/energy
Industrial	www.ti.com/industrial
Medical	www.ti.com/medical
Security	www.ti.com/security
Space, Avionics and Defense	www.ti.com/space-avionics-defense
Video and Imaging	www.ti.com/video

TI E2E Community

e2e.ti.com