

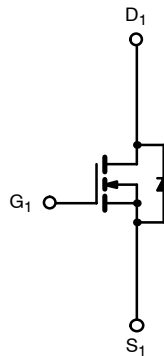

Dual N-Channel 2.5-V (G-S) MOSFET

PRODUCT SUMMARY		
V_{DS} (V)	$r_{DS(on)}$ (Ω)	I_D (A)
20	0.030 @ $V_{GS} = 4.5$ V	4.5
	0.033 @ $V_{GS} = 3.0$ V	4.2
	0.035 @ $V_{GS} = 2.5$ V	3.9
	0.043 @ $V_{GS} = 1.8$ V	3.6

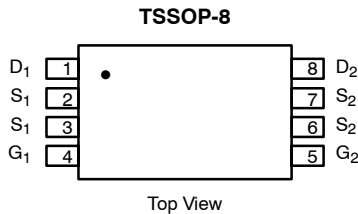

N-Channel MOSFET

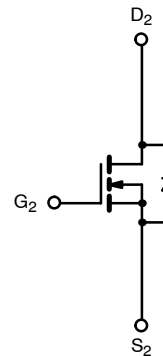

N-Channel MOSFET

Ordering Information: Si6926ADQ-T1—E3 (Lead Free)

ABSOLUTE MAXIMUM RATINGS ($T_A = 25^\circ\text{C}$ UNLESS OTHERWISE NOTED)					
Parameter	Symbol	10 secs	Steady State	Unit	
Drain-Source Voltage	V_{DS}	20		V	
Gate-Source Voltage	V_{GS}	± 8			
Continuous Drain Current ($T_J = 150^\circ\text{C}$) ^a	I_D	$T_A = 25^\circ\text{C}$	4.5	4.1	A
		$T_A = 70^\circ\text{C}$	3.6	3.3	
Pulsed Drain Current (10 μs Pulse Width)	I_{DM}	20			
Continuous Source Current (Diode Conduction) ^a	I_S	0.83	0.69		
Maximum Power Dissipation ^a	P_D	$T_A = 25^\circ\text{C}$	1.0	0.83	W
		$T_A = 70^\circ\text{C}$	0.64	0.53	
Operating Junction and Storage Temperature Range	T_J, T_{stg}	-55 to 150		$^\circ\text{C}$	

THERMAL RESISTANCE RATINGS					
Parameter	Symbol	Typical	Maximum	Unit	
Maximum Junction-to-Ambient ^a	R_{thJA}	$t \leq 10$ sec	90	125	$^\circ\text{C}/\text{W}$
		Steady State	126	150	
Maximum Junction-to-Foot (Drain)	R_{thJF}	65	80		

Notes

a. Surface Mounted on FR4 Board, $t \leq 10$ sec.

For SPICE model information via the Worldwide Web: <http://www.vishay.com/www/product/spice.htm>



SPECIFICATIONS (T _J = 25 °C UNLESS OTHERWISE NOTED)						
Parameter	Symbol	Test Condition	Min	Typ ^a	Max	Unit
Static						
Gate Threshold Voltage	V _{GS(th)}	V _{DS} = V _{GS} , I _D = 250 μA	0.40		1.0	V
Gate-Body Leakage	I _{GSS}	V _{DS} = 0 V, V _{GS} = ± 8 V			± 100	nA
Zero Gate Voltage Drain Current	I _{DSS}	V _{DS} = 20 V, V _{GS} = 0 V			1	μA
		V _{DS} = 20 V, V _{GS} = 0 V, T _J = 55 °C			5	
On-State Drain Current ^b	I _{D(on)}	V _{DS} ≥ 5 V, V _{GS} = 5 V	10			A
Drain-Source On-State Resistance ^b	r _{DS(on)}	V _{GS} = 4.5 V, I _D = 4.5 A		0.024	0.030	Ω
		V _{GS} = 3.0 V, I _D = 4.2 A		0.026	0.033	
		V _{GS} = 2.5 V, I _D = 3.9 A		0.029	0.035	
		V _{GS} = 1.8 V, I _D = 3.6 A		0.035	0.043	
Forward Transconductance ^b	g _{fs}	V _{DS} = 10 V, I _D = 4.5 A		26		S
Diode Forward Voltage ^b	V _{SD}	I _S = 0.83 A, V _{GS} = 0 V		0.6	1.1	V
Dynamic^a						
Total Gate Charge	Q _g	V _{DS} = 10 V, V _{GS} = 4.5 V, I _D = 4.5 A		7.5	10.5	nC
Gate-Source Charge	Q _{gs}			1.2		
Gate-Drain Charge	Q _{gd}			1.2		
Gate Resistance	R _g			1.9		Ω
Turn-On Delay Time	t _{d(on)}	V _{DD} = 10 V, R _L = 10 Ω I _D ≅ 1 A, V _{GEN} = 10 V, R _g = 6 Ω		6	12	ns
Rise Time	t _r			16	25	
Turn-Off Delay Time	t _{d(off)}			46	70	
Fall Time	t _f			9	15	
Source-Drain Reverse Recovery Time	t _{rr}	I _F = 0.83 A, di/dt = 100 A/μs		20	40	

Notes

- a. Guaranteed by design, not subject to production testing.
- b. Pulse test; pulse width ≤ 300 μs, duty cycle ≤ 2%.

TYPICAL CHARACTERISTICS (25 °C UNLESS NOTED)

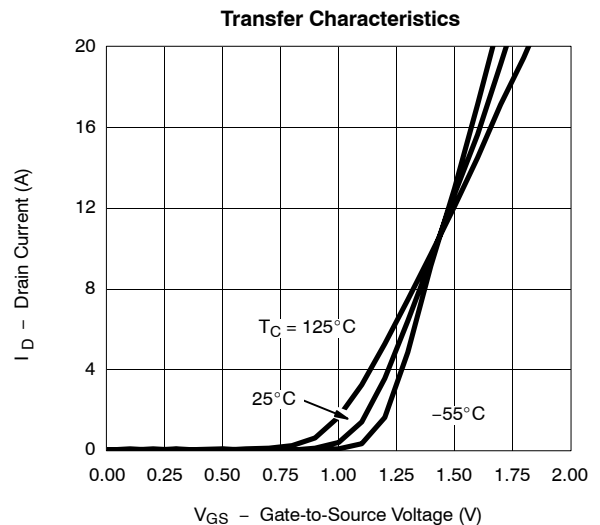
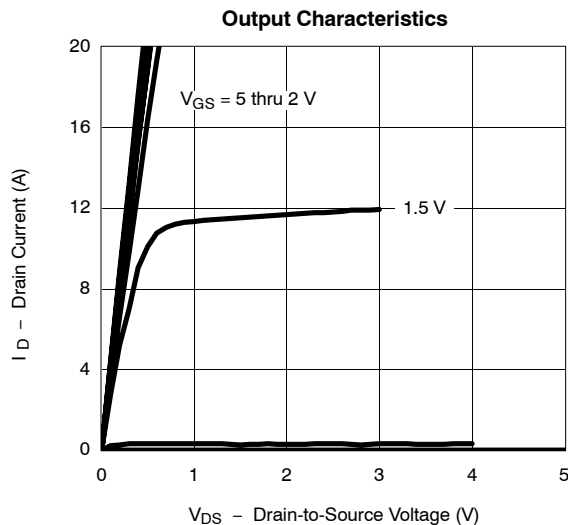



TYPICAL CHARACTERISTICS (25 °C UNLESS NOTED)

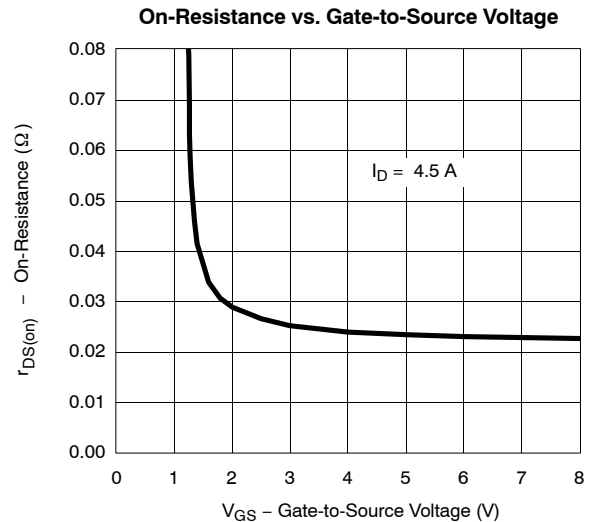
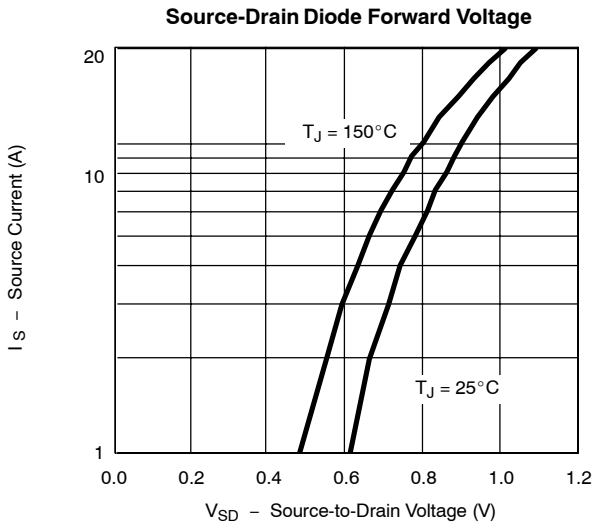
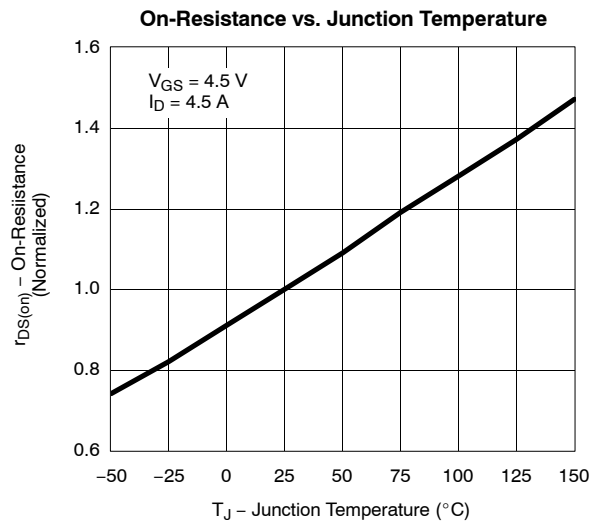
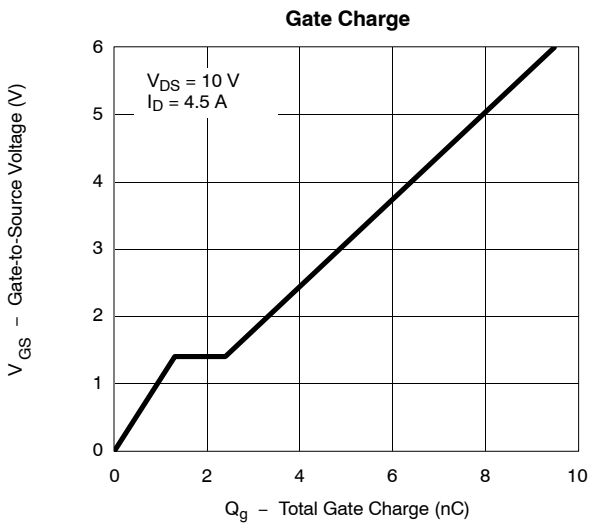
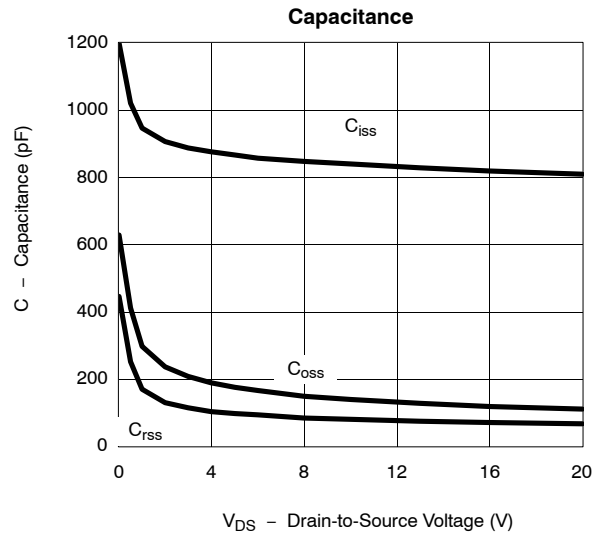
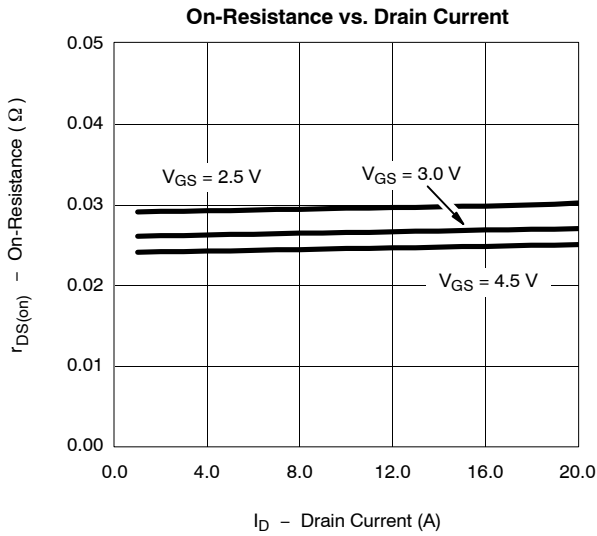



TYPICAL CHARACTERISTICS (25 °C UNLESS NOTED)

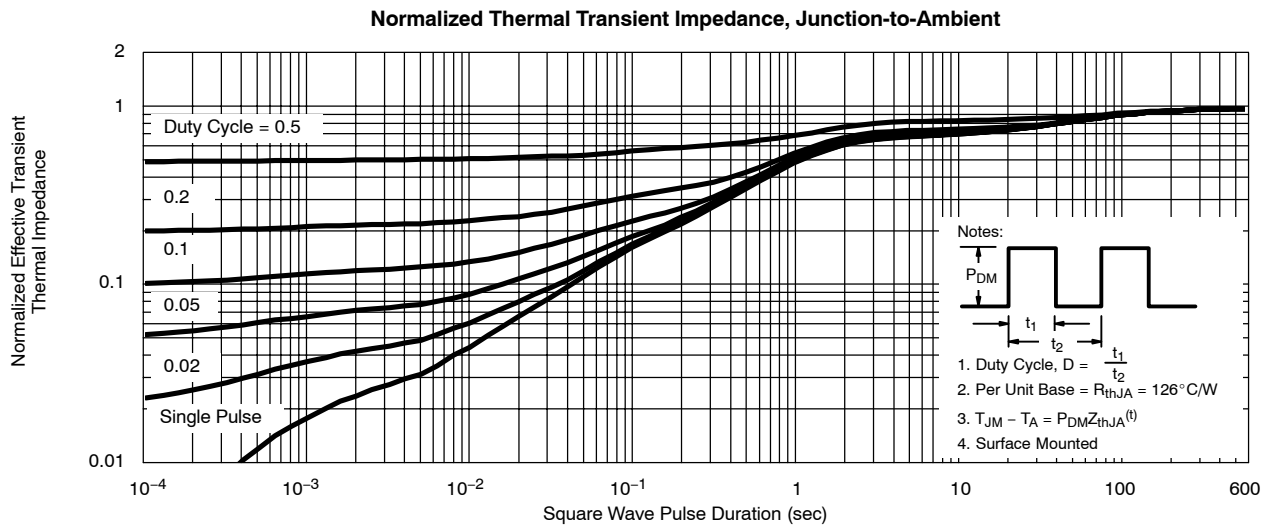
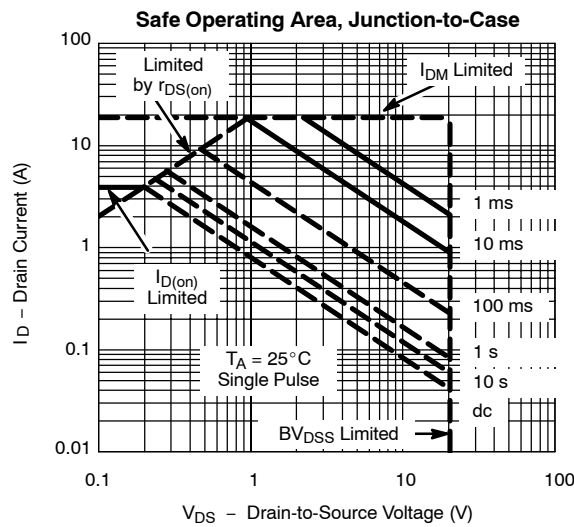
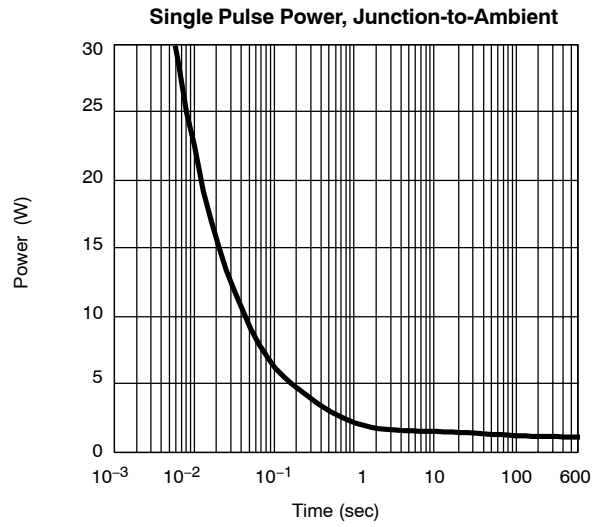
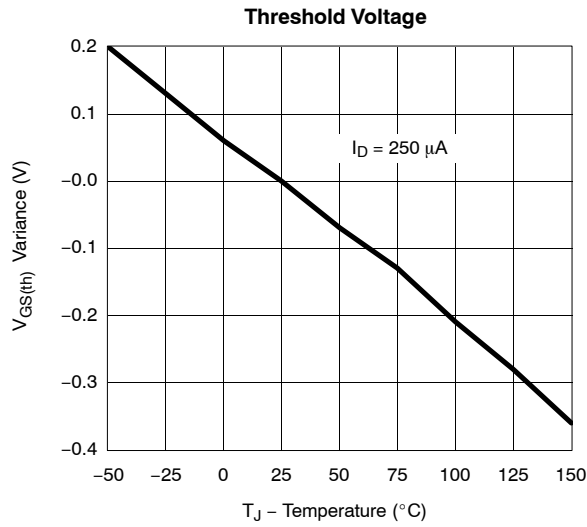



TYPICAL CHARACTERISTICS (25 °C UNLESS NOTED)

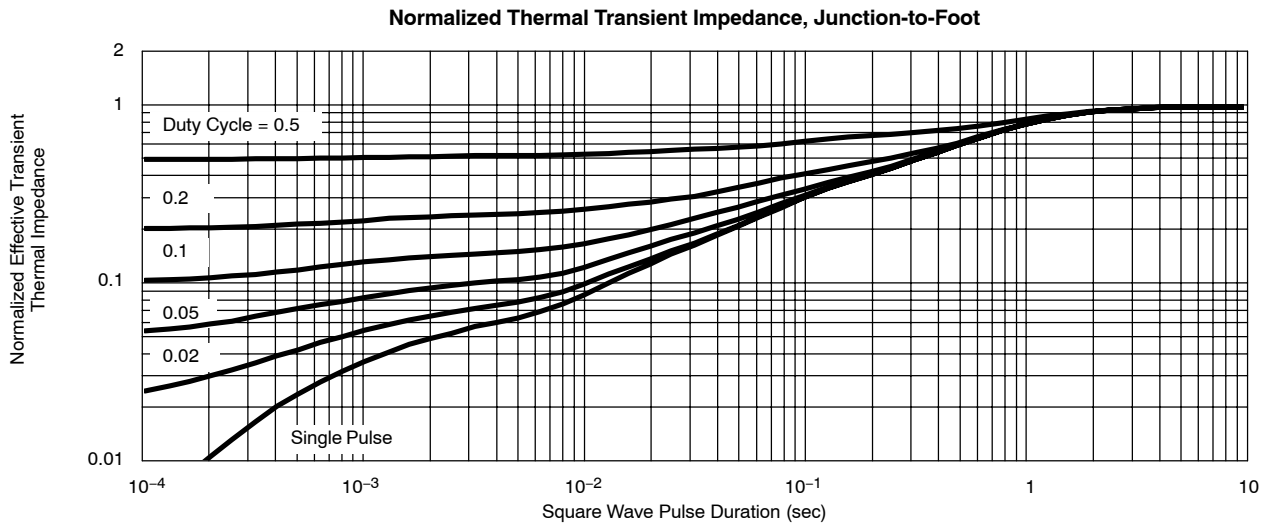



Notice

Specifications of the products displayed herein are subject to change without notice. Vishay Intertechnology, Inc., or anyone on its behalf, assumes no responsibility or liability for any errors or inaccuracies.

Information contained herein is intended to provide a product description only. No license, express or implied, by estoppel or otherwise, to any intellectual property rights is granted by this document. Except as provided in Vishay's terms and conditions of sale for such products, Vishay assumes no liability whatsoever, and disclaims any express or implied warranty, relating to sale and/or use of Vishay products including liability or warranties relating to fitness for a particular purpose, merchantability, or infringement of any patent, copyright, or other intellectual property right.

The products shown herein are not designed for use in medical, life-saving, or life-sustaining applications. Customers using or selling these products for use in such applications do so at their own risk and agree to fully indemnify Vishay for any damages resulting from such improper use or sale.



TSSOP: 8-LEAD

JEDEC Part Number: MO-153

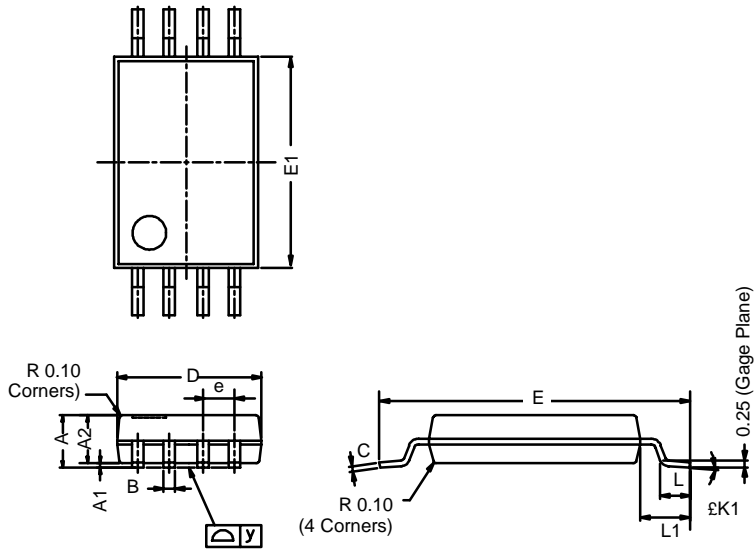

Dim	MILLIMETERS		
	Min	Nom	Max
A	–	–	1.20
A ₁	0.05	0.10	0.15
A ₂	0.80	1.00	1.05
B	0.19	0.28	0.30
C	–	0.127	–
D	2.90	3.00	3.10
E	6.20	6.40	6.60
E ₁	4.30	4.40	4.50
e	–	0.65	–
L	0.45	0.60	0.75
L ₁	0.90	1.00	1.10
Y	–	–	0.10
£K1	0°	3°	6°

ECN: S-03946—Rev. G, 09-Jul-01
DWG: 5844

RECOMMENDED MINIMUM PADS FOR TSSOP-8

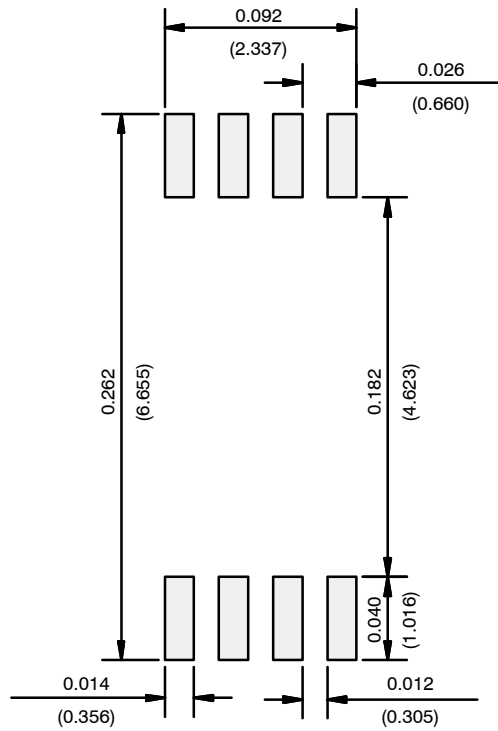

Recommended Minimum Pads
Dimensions in Inches/(mm)

[Return to Index](#)

Vishay Lead-Free Family Summary Sheet-Active Components

Product Description		Pb Free "2nd-Level Interconnect" Status									RoHS Status				Soldering			PCN-Status	
Technology/ Product Line	Product Family	Vishay Division	Pb-free Qual. Complete and Report Available (Q/Y)	Pb-free Samples available (Q/Y)	Pb-free Massproduction (Q/Y)	Termination Finish	Underlayer	Lead or Base material	How to Order-Web (Lead Free)	Tin Lead (SnPb) Products/Termination available after Conversion	RoHS Qual. Complete and Report Available (Q/Y)	RoHS-Compl Samples (Q/Y)	RoSH-Compl Massproduction (Q/Y)	Exemptions Used	Moisture Sensitivity Level	IPC/JEDEC-J-STD-020C compliant (Temp. Peak T _p in °C/ Time Peak t _p in sec/ Cycles)	Backward Compatibility	Product Change Notification No#./ Ref#	Product Change Notification Date
MOSFETS																			
PMOS, SC-70	SI1xxxDL	SI	2/04	3/03	2/04	100% Sn matte	None	Alloy42	add "-E3"	YES	2/04	3/03	2/04	None	1	✓	✓	03014	June, 03
PMOS, SC-70	SI1xxxDH	SI	2/04	3/03	2/04	100% Sn matte	None	Cu	add "-E3"	YES	2/04	3/03	2/04	None	1	✓	✓	03014	June, 03
PMOS, SC-75A	SI1xxxR	SI	2/04	3/03	2/04	100% Sn matte	None	Alloy42	add "-E3"	YES	2/04	3/03	2/04	None	1	✓	✓	03014	June, 03
PMOS, SC-89	SI1xxxX	SI	2/04	3/03	2/04	100% Sn matte	None	Cu	add "-E3"	YES	2/04	3/03	2/04	None	1	✓	✓	03014	June, 03
PMOS, SOT-23	SI2xxxDS	SI	2/04	3/03	2/04	100% Sn matte	None	Cu	add "-E3"	YES	2/04	3/03	2/04	None	1	✓	✓	03014	June, 03
PMOS, Small Signal, SOT-23	2N7002x, TNxxxxK, VNxxxxK, TPxxxxK, VPxxxxK	SI	2/04	3/03	2/04	100% Sn matte	None	Alloy42	add "-E3"	YES	2/04	3/03	2/04	None	1	✓	✓	03014	June, 03
PMOS, Small Signal, TO-92	2N7000KL, TNxxxxKL, VNxxxxKL, TPxxxxKL, VPxxxxKL	SI	2/04	3/03	2/04	100% Sn matte	None	Alloy42	add "-E3"	YES	2/04	3/03	2/04	None	1	✓	✓	03014	June, 03
PMOS, TSOP-6	SI3xxxDV	SI	2/04	3/03	2/04	100% Sn matte	None	Cu	add "-E3"	YES	2/04	3/03	2/04	None	1	✓	✓	03014	June, 03
PMOS, SOIC	SI4xxxDY, SI6xxxEY, SI9xxxDY, SI9xxxEY	SI	2/04	3/03	2/04	100% Sn matte	None	Cu	add "-E3"	YES	2/04	3/03	2/04	High Temperature die attach solder	1	✓	✓	03014	June, 03
PMOS, ChipFET	SI5xxxDC	SI	2/04	3/03	2/04	100% Sn matte	None	Cu	add "-E3"	YES	2/04	3/03	2/04	None	1	✓	✓	03014	June, 03
PMOS, ChipFET PowerP	SI5xxxDU	SI	2/04	3/03	2/04	100% Sn matte	None	Cu	add "-E3"	YES	2/04	3/03	2/04	None	1	✓	✓	03014	June, 03
PMOS, TSSOP-8	SI6xxxDQ	SI	2/04	3/03	2/04	100% Sn matte	None	Cu	add "-E3"	YES	2/04	3/03	2/04	High Temperature die attach solder	1	✓	✓	03014	June, 03
PMOS, PowerPAK 1212	SI7xxxDN	SI	2/04	3/03	2/04	100% Sn matte	None	Cu	add "-E3"	YES	2/04	3/03	2/04	High Temperature die attach solder	1	✓	✓	03014	June, 03
PMOS, PowerPAK SO8	SI7xxxDP	SI	2/04	3/03	2/04	100% Sn matte	None	Cu	add "-E3"	YES	2/04	3/03	2/04	High Temperature die attach solder	1	✓	✓	03014	June, 03
PMOS, MicroFOOT	SI8xxxDB	SI	2/04	3/03	2/04	Sn/Ag/Cu	None	Lead-Free	add "-E1"	NO	2/04	3/03	2/04	None	NA	✓	✓	03014	June, 03
PMOS, PowerPAK MLF	SI Cxxxxxxxx	SI	4/06	4/06	4/06	100% Sn matte	None	Cu	add "-E3"	YES	4/06	4/06	4/06	None	1	245/40/3	NO	NA	NA
PMOS, PolarPAK	SI ExxxDF	SI	2/04	3/03	2/04	100% Sn matte	None	Cu	add "-E3"	YES	2/04	3/03	2/04	High Temperature die attach solder	1	✓	✓	03014	June, 03
PMOS, PowerPAK 2 x 5	SI FxxxDZ	SI	2/04	3/03	2/04	100% Sn matte	None	Cu	add "-E3"	YES	2/04	3/03	2/04	High Temperature die attach solder	1	✓	✓	03014	June, 03
PMOS, TO-263	SUBxxxxxx-xx, SUMxxxxxx-xx	SI	2/04	3/03	2/04	100% Sn matte	Ni	Cu	add "-E3"	YES	2/04	3/03	2/04	High Temperature die attach solder	1	✓	✓	03014	June, 03
PMOS, TO-252	SUDxxxxxx-xx, SURxxxxxx-xx	SI	2/04	3/03	2/04	100% Sn matte	Ni	Cu	add "-E3"	YES	2/04	3/03	2/04	High Temperature die attach solder	1	✓	✓	03014	June, 03
PMOS, TO-220	SUPxxxxxx-xx, SUNxxxxxx-xx	SI	2/04	3/03	2/04	100% Sn matte	Ni	Cu	add "-E3"	YES	2/04	3/03	2/04	High Temperature die attach solder	1	✓	✓	03014	June, 03

Vishay Lead-Free Family Summary Sheet-Active Components

Product Description		Pb Free "2nd-Level Interconnect" Status								RoHS Status				Soldering		PCN-Status			
Technology/ Product Line	Product Family	Vishay Division	Pb-free Qual. Complete and Report Available (Q/Y)	Pb-free Samples available (Q/Y)	Pb-free Massproduction (Q/Y)	Termination Finish	Underlayer	Lead or Base material	How to Order-Web (Lead Free)	Tin Lead (SnPb) Products/Termination available after Conversion	RoHS Qual. Complete and Report Available (Q/Y)	RoHS-Compl Samples (Q/Y)	RoSH-Compl Massproduction (Q/Y)	Exemptions Used	Moisture Sensitivity Level	IPC/JEDEC J-STD-020C compliant (Temp. Peak T _p in °C/ Time Peak t _p in sec/ Cycles)	Backward Compatibility	Product Change Notification No#./ Ref#	Product Change Notification Date
PMOS, TO-251	SUUxxxxxx-xx	SI	2/04	3/03	2/04	100% Sn matte	Ni	Cu	add "-E3"	YES	2/04	3/03	2/04	High Temperature die attach solder	1	✓	✓	03014	June, 03
PMOS, TO-262	SUVxxxxxx-xx	SI	2/04	3/03	2/04	100% Sn matte	Ni	Cu	add "-E3"	YES	2/04	3/03	2/04	High Temperature die attach solder	1	✓	✓	03014	June, 03
JFET's																			
JFET, Hermetic	CRxxx, PADxx, DPADx, 2Nxxx, Uxxx, VCRxxx	SI	2/04	3/03	2/04	100% Sn matte	None	Alloy42	add "-E3"	NO	2/04	3/03	2/04	None	1	✓	✓	03014	June, 03
JFET, TO-92	Jxxx, JPADxx, PNxxxx	SI	2/04	3/03	2/04	100% Sn matte	None	Cu	add "-E3"	YES	2/04	3/03	2/04	None	1	✓	✓	03014	June, 03
JFET, SOT-23	SSTxxx	SI	2/04	3/03	2/04	100% Sn matte	None	Cu	add "-E3"	YES	2/04	3/03	2/04	None	1	✓	✓	03014	June, 03
JFET, SOIC	SSDTPADxxx	SI	2/04	3/03	2/04	100% Sn matte	None	Cu	add "-E3"	YES	2/04	3/03	2/04	None	1	✓	✓	03014	June, 03
INTEGRATED CIRCUITS																			
LinIC, HV SOIC	DGxxxDY, DGxxxDW	SI	4/04	4/04	1/05	100% Sn matte	None	Cu	add "-E3"	YES	4/04	4/04	1/05	None	1	✓	✓	03014	June, 03
LinIC, HV PDIP	DGxxxDJ	SI	4/04	4/04	1/05	100% Sn matte	None	Cu	add "-E3"	YES	4/04	4/04	1/05	None	1	✓	✓	03014	June, 03
LinIC, HV TSSOP	DGxxxDQ	SI	2/04	3/03	2/04	100% Sn matte	None	Cu	add "-E3"	YES	2/04	3/03	2/04	None	1	✓	✓	03014	June, 03
LinIC, HV PLCC	DGxxxDN	SI	4/04	4/04	1/05	100% Sn matte	None	Cu	add "-E3"	YES	4/04	4/04	1/05	None	1	✓	✓	03014	June, 03
LinIC, LV MSOP	DGxxxDQ	SI	4/04	4/04	1/05	100% Sn matte	None	Cu	add "-E3"	YES	4/04	4/04	1/05	None	1	✓	✓	03014	June, 03
LinIC, LV TSOP	DGxxxDV	SI	2/04	3/03	2/04	100% Sn matte	None	Cu	add "-E3"	YES	2/04	3/03	2/04	None	1	✓	✓	03014	June, 03
LinIC, LV SC-89	DGxxxDX	SI	2/04	3/03	2/04	100% Sn matte	None	Cu	add "-E3"	YES	2/04	3/03	2/04	None	1	✓	✓	03014	June, 03
LinIC, LV SC-70	DGxxxDL	SI	2/04	3/03	2/04	100% Sn matte	None	Cu	add "-E3"	YES	2/04	3/03	2/04	None	1	✓	✓	03014	June, 03
LinIC, LV QFN	DGxxxDN	SI	4/04	4/04	1/05	Ni/Pd/Au	None	Cu	add "-E4"	YES	4/04	4/04	1/05	None	1	✓	✓	03014	June, 03
LinIC, LV SOT-23	DGxxxDS	SI	2/04	3/03	2/04	100% Sn matte	None	Cu	add "-E3"	YES	2/04	3/03	2/04	None	1	✓	✓	03014	June, 03
LinIC, LV MicroFOOT	DGxxxDB	SI	2/04	3/03	2/04	Sn/Ag/Cu	None	Lead-Fra	add "-E1"	NO	2/04	3/03	2/04	None	NA	✓	✓	03014	June, 03
PIC, SSOP	SI786xxxG, SI913xxG	SI	3/04	4/04	4/04	100% Sn matte	None	Cu	add "-E3"	YES	3/04	4/04	4/04	None	1	250/40/3	✓	N/A	June, 03
PIC, MSOP	SI91xxxH, SI9xxxH	SI	3/04	4/04	4/04	100% Sn matte	None	Cu	add "-E3"	YES	3/04	4/04	4/04	None	1	✓	✓	N/A	June, 03
PIC, PDIP	SI91xxDJ	SI	3/04	4/04	4/04	100% Sn matte	None	Cu	add "-E3"	YES	3/04	4/04	4/04	None	1	250/40/3	✓	03014	June, 03
PIC, QSOP	SI9xxxG	SI	3/04	4/04	4/04	100% Sn matte	None	Cu	add "-E3"	YES	3/04	4/04	4/04	None	1	250/40/3	✓	03014	June, 03
PIC, MLP	SI91xxxDM, SI9xxxDM	SI	3/04	4/04	4/04	100% Sn matte	None	Cu	add "-E3"	YES	3/04	4/04	4/04	None	1	250/40/3	✓	03014	June, 03
PIC, PLCC	SI91xxDN	SI	3/04	4/04	4/04	100% Sn matte	None	Cu	add "-E3"	YES	3/04	4/04	4/04	None	1	250/40/3	✓	03014	June, 03
PIC, PowerPAK	SI91xxDLP, SI9xxxDLP, SI91xxDMP, SI9xxxDMP	SI	3/04	4/04	4/04	100% Sn matte	None	Cu	add "-E3"	YES	3/04	4/04	4/04	High Temperature die attach solder	1	250/40/3	✓	03014	June, 03
PIC, TSSOP	SI91xxxQ, SI9xxxQ, SI9xxxQDQ	SI	3/04	4/04	4/04	100% Sn matte	None	Cu	add "-E3"	YES	3/04	4/04	4/04	High Temperature die attach solder	1	250/40/3	✓	03014	June, 03
PIC, SC-70	SI9xxxDR	SI	3/04	4/04	4/04	100% Sn matte	None	Cu	add "-E3"	YES	3/04	4/04	4/04	None	1	✓	✓	03014	June, 03
PIC, SQFP	SI99xxCS, SI9xxxCS	SI	3/04	4/04	4/04	100% Sn matte	None	Cu	add "-E3"	YES	3/04	4/04	4/04	None	1	250/40/3	✓	03014	June, 03
PIC, SOT-23	SI91xxDT, SI9xxxDT	SI	3/04	4/04	4/04	100% Sn matte	None	Cu	add "-E3"	YES	3/04	4/04	4/04	None	1	250/40/3	✓	03014	June, 03
PIC, SOIC	SI9xxxDW, SI9xxxDY, SI9xxxDY	SI	3/04	4/04	4/04	100% Sn matte	None	Cu	add "-E3"	YES	3/04	4/04	4/04	None	1	250/40/3	✓	03014	June, 03
HIREL	IC's, JFETS, MOSFETS	SI	NA	NA	NA	Tin/Lead			NA	NA	NA	NA	----	NA	NA	NA	NA	NA	NA
FUNCTION PACK																			
Function PAK	FXxxxxxxxxxx	SI	3/06	3/06	3/06	Sn/Ag/Cu	None	NA	add "-E2"	YES	3/06	3/06	3/06	TBD	TBD	TBD	NA	TBD	TBD

Vishay Lead-Free Family Summary Sheet-Active Components

Product Description		Pb Free "2nd-Level Interconnect" Status								RoHS Status				Soldering			PCN-Status		
Technology/ Product Line	Product Family	Vishay Division	Pb-free Qual. Complete and Report Available (Q/Y)	Pb-free Samples available (Q/Y)	Pb-free Massproduction (Q/Y)	Termination Finish	Underlayer	Lead or Base material	How to Order-Web (Lead Free)	Tin Lead (SnPb) Products/Termination available after Conversion	RoHS Qual. Complete and Report Available (Q/Y)	RoHS-Compl Samples (Q/Y)	RoSH-Compl Massproduction (Q/Y)	Exemptions Used	Moisture Sensitivity Level	IPC/JEDEC J-STD-020C compliant (Temp. Peak T _p in °C/ Time Peak t _p in sec / Cycles)	Backward Compatibility	Product Change Notification No#./ Ref#	Product Change Notification Date
SMALL SIGNAL PRODUCTS																			
Glass products	DO 35, DO 41	VS	✓	✓	3/04	SnAg 3.5% Hot plating	None	Cu	Standard Part number	NO	2/03	3/03	3/04	Leadoxide in Glass package	1	✓	✓	14 24	18.04.2003 06.06.2003
Glass products	SOD 80, MicroMelf	VS	✓	✓	3/04	SnAg 2.5% Hot plating	None	Cu	Standard Part number	NO	2/03	3/03	3/04	Leadoxide in Glass package	1	✓	✓	14 24	18.04.2003 06.06.2003
Glassbead Diodes	DOT 30B, SOD 57, SOD 64	VS	✓	✓	1/05	SnAg 3.5% Hot plating	None	Cu	Standard Part number	NO	2/03	3/03	1/05	Leadoxide in Glass package	1	✓	✓	14 24	18.04.2003 06.06.2003
Glassbead Diodes	G1;G3,G4	VS	✓	✓	NO	Sn +3000ppm Pb	None	Cu	New Part Number	NO	TBD	TBD	NO	Leadoxide in Glass package	1	✓	✓	39	8/14/2003
Plastic products	DO 213 AB Plastic (GLL 47xx)	VS	✓	✓	1/06	100% Sn matte	None	Cu	New Part Number	NO	1/05	1/05	1/05	Chip soldering, Glass passivation	1	✓	✓	39	8/14/2003
Plastic products	SMA-Zener (SML 47xx)	VS	✓	✓	1/06	100% Sn matte	None	Cu	New Part Number	NO	1/05	1/05	1/05	Chip soldering	1	✓	✓	39	8/14/2003
Plastic products	SOT 143,TO 50, LLP xx,SOT 3xx, TO92, SOT490, SOD523	VS	✓	✓	3/04	100% Sn matte	None	Cu	Standard Part number	NO	2/03	3/03	3/04		1	✓	✓	14 24	18.04.2003 06.06.2003
Plastic products	SOT 23, SOD 123,323 (Thermoplast)	VS	✓	✓	1/05	100% Sn matte	None	Cu	Standard Part number	NO	2/03	3/03	1/05		1	✓	✓	14 24	18.04.2003 06.06.2003
Plastic products	SOT 23-V, SOD 123-V,323-V, DO219 (Duroplast)	VS	✓	✓	1/05	100% Sn matte	None	Cu	Standard Part number	NO	2/03	3/03	1/05	Chip solder DO 219	1	✓	✓	14 24	18.04.2003 06.06.2003
Plastic products	SOT 23HF, DO 214-Zener	VS	✓	✓	1/05	100% Sn matte	None	Cu	Standard Part number	NO	2/03	3/03	1/05	Chip solder DO 214	1	✓	✓	14 24	18.04.2003 06.06.2003
Plastic products	TO 220	VS	✓	✓	1/05	100% Sn matte	None	Cu	Standard Part number	NO	2/05	2/05	1/05	Chip solder TO 220	2	✓	✓	19	July 2005
MELF glass	DO 213 AB	VS	✓	✓	1/05	SnAg 2.5% Hot plating	None	Cu	Standard Part number	NO	3/04	3/04	1/05	Lead in Glass package	1	✓	✓	14 24	18.04.2003 06.06.2003
POWER DIODES																			
PPAK	TO-220 - COMMERCIAL	VS	2/06	✓	✓	100% Sn matte	NONE	Cu	Standard P/N add "-E3"	NO	✓	✓	✓	Pb in HT Solder DA, Pb in passivation	NA	NA	YES	39 Rev.4	Apr.28/06
PPAK	TO262 - COMMERCIAL	VS	2/06	✓	✓	100% Sn matte	NONE	Cu	Standard P/N add "-E3"	NO	✓	✓	✓	Pb in HT Solder DA, Pb in passivation	NA	NA	YES	39 Rev.4	Apr.28/06
PPAK	T03P - COMMERCIAL	VS	2/06	✓	✓	100% Sn matte	NONE	Cu	Standard P/N add "-E3"	NO	✓	✓	✓	Pb in HT Solder DA, Pb in passivation	NA	NA	YES	39 Rev.4	Apr.28/06
PPAK	IT0220 - COMMERCIAL	VS	2/06	✓	✓	100% Sn matte	NONE	Cu	Standard P/N add "-E3"	NO	✓	✓	✓	Pb in HT Solder DA, Pb in passivation	NA	NA	YES	39 Rev.4	Apr.28/06
PPAK	TO-263 - COMMERCIAL	VS	2/06	✓	✓	100% Sn matte	Ni	Cu	Standard P/N add "-E3"	NO	✓	✓	✓	Pb in HT Solder DA, Pb in passivation	1	✓	YES	39 Rev.4	Apr.28/06
PPAK	TO-220 - AUTOMOTIVE	VS	3/06	✓	✓	100% Sn matte	NONE	Cu	Standard P/N add "HE3"	YES	✓	✓	✓	Pb in HT Solder DA, Pb in passivation	NA	NA	YES	39 Rev.4	Apr.28/06
PPAK	ITO-220 - AUTOMOTIVE	VS	3/06	✓	✓	100% Sn matte	NONE	Cu	Standard P/N add "HE3"	YES	✓	✓	✓	Pb in HT Solder DA, Pb in passivation	NA	NA	YES	39 Rev.4	Apr.28/06
PPAK	TO-263 - AUTOMOTIVE	VS	3/06	✓	✓	100% Sn matte	Ni	Cu	Standard P/N add "HE3"	YES	✓	✓	✓	Pb in HT Solder DA, Pb in passivation	1	✓	YES	39 Rev.4	Apr.28/06

Vishay Lead-Free Family Summary Sheet-Active Components

Product Description		Pb Free "2nd-Level Interconnect" Status							RoHS Status				Soldering		PCN-Status				
Technology/ Product Line	Product Family	Vishay Division	Pb-free Qual. Complete and Report Available (Q/Y)	Pb-free Samples available (Q/Y)	Pb-free Massproduction (Q/Y)	Termination Finish	Underlayer	Lead or Base material	How to Order-Web (Lead Free)	Tin Lead (SnPb) Products/Termination available after Conversion	RoHS Qual. Complete and Report Available (Q/Y)	RoHS-Compl Samples (Q/Y)	RoSH-Compl Massproduction (Q/Y)	Exemptions Used	Moisture Sensitivity Level	IPC/JEDEC-J-STD-020C compliant (Temp. Peak T _p in °C/ Time Peak t _p in sec/ Cycles)	Backward Compatibility	Product Change Notification No#./ Ref#	Product Change Notification Date
Bridge	GSIB4, DFM, MBM, GBL, GBU, GSIB - COMMERCIAL	VS	2/06	✓	✓	100% Sn matte	NONE	Cu	Standard P/N add "-E3"	NO	✓	✓	✓	Pb in HT solder DA, Pb in passivation	NA	NA	YES	39 Rev.4	Apr.28/06
Bridge	MBS, DFS - COMMERCIAL	VS	2/06	✓	✓	100% Sn matte	NONE	Cu	Standard P/N add "-E3"	NO	✓	✓	✓	Pb in HT solder DA, Pb in passivation glass	1	✓	YES	39 Rev.4	Apr.28/06
Bridge	KBPM, KBL, KBU, BC, GBPC (Wire Lead Type), WOG - COMMERCIAL	VS	NA	✓	✓	100% Ag	NONE	Cu	Standard P/N add "-E4"	NA	✓	✓	✓	Pb in HT solder DA, Pb in passivation	NA	NA	YES	39 Rev.4	Apr.28/06
Bridge	GBPC (terminal Type) - COMMERCIAL	VS	NA	✓	✓	Ni	NONE	Cu	Standard P/N add "-E4"	NA	✓	✓	✓	Pb in HT solder DA, Pb in passivation glass	NA	NA	YES	39 Rev.4	Apr.28/06
SMX RECT	SMP, SMA, SMB, SMC - COMMERCIAL	VS	2/06	✓	✓	100% Sn matte	NONE	Cu	Standard P/N add "-E3"	NO	✓	✓	✓	Pb in HT solder DA, Pb in passivation glass	1	✓	YES	39 Rev.4	Apr.28/06
SMX TVS	SMP, SMA, SMB, SMC - COMMERCIAL	VS	2/06	✓	✓	100% Sn matte	NONE	Cu	Standard P/N add "-E3"	NO	✓	✓	✓	Pb in HT solder DA, Pb in passivation glass	1	✓	YES	39 Rev.4	Apr.28/06
SMX RECT	SMA, SMB, SMC - 'B' SERIES	VS	2/06	✓	✓	100% Sn matte	NONE	Cu	Standard P/N add "-E3"	NO	✓	✓	✓	Pb in HT solder DA, Pb in passivation glass	1	✓	YES	39 Rev.4	Apr.28/06
SMX RECT	SMP, SMA, SMB, SMC - AUTOMOTIVE	VS	3/06	✓	✓	100% Sn matte	NONE	Cu	Standard P/N add "HE3"	YES	✓	✓	✓	Pb in HT solder DA, Pb in passivation glass	1	✓	YES	39 Rev.4	Apr.28/06
SMX TVS	SMP, SMA, SMB, SMC - AUTOMOTIVE	VS	3/06	✓	✓	100% Sn matte	NONE	Cu	Standard P/N add "HE3"	YES	✓	✓	✓	Pb in HT solder DA, Pb in passivation glass	1	✓	YES	39 Rev.4	Apr.28/06
SMX TVS	D0218 LOAD DUMP - AUTOMOTIVE	VS	3/06	✓	✓	100% Sn matte	Ni	Cu	Standard P/N add "HE3"	YES	✓	✓	✓	Pb in HT solder DA, Pb in passivation glass	1	✓	YES	39 Rev.4	Apr.28/06
SMX RECT	GL41/GL34 - COMMERCIAL	VS	2/06	✓	ü	100% Sn matte	NONE	Cu	Standard P/N add "-E3"	NO	✓	✓	✓	Pb in HT solder DA, Pb in passivation glass	1	✓	YES	39 Rev.4	Apr.28/06
SMX RECT	GL41/GL34 - AUTOMOTIVE	VS	3/06	✓	ü	100% Sn matte	NONE	Cu	Standard P/N add "HE3"	YES	✓	✓	✓	Pb in HT solder DA, Pb in passivation glass	1	✓	YES	39 Rev.4	Apr.28/06
SMX TVS	GL41 - COMMERCIAL	VS	2/06	✓	✓	100% Sn matte	NONE	Cu	Standard P/N add "-E3"	NO	✓	✓	✓	Pb in HT solder DA, Pb in passivation glass	1	✓	YES	39 Rev.4	Apr.28/06
SMX RECT	GF1 - COMMERCIAL	VS	2/06	✓	ü	100% Sn matte	NONE	Cu	Standard P/N add "-E3"	NO	✓	✓	✓	Pb in HT solder DA, Pb in passivation glass	1	✓	YES	39 Rev.4	Apr.28/06
SMX RECT	GF1 - AUTOMOTIVE	VS	3/06	✓	✓	100% Sn matte	NONE	Cu	Standard P/N add "HE3"	YES	✓	✓	✓	Pb in HT solder DA, Pb in passivation glass	1	✓	YES	39 Rev.4	Apr.28/06
Axial RECT	PLASTIC, GPP, SKY, FER, IN DO41, DO15, DO201AD, MPG06, P600 - COMMERCIAL	VS	2/06	✓	✓	100% Sn matte	NONE	Cu	Standard P/N add "-E3"	NO	✓	✓	✓	Pb in HT solder DA, Pb in passivation glass	NA	NA	YES	39 Rev.4	Apr.28/06

Vishay Lead-Free Family Summary Sheet-Active Components

Product Description		Pb Free "2nd-Level Interconnect" Status								RoHS Status				Soldering			PCN-Status		
Technology/ Product Line	Product Family	Vishay Division	Pb-free Qual. Complete and Report Available (Q/Y)	Pb-free Samples available (Q/Y)	Pb-free Massproduction (Q/Y)	Termination Finish	Underlayer	Lead or Base material	How to Order-Web (Lead Free)	Tin Lead (SnPb) Products/Termination available after Conversion	RoHS Qual. Complete and Report Available (Q/Y)	RoHS-Compl Samples (Q/Y)	RoSH-Compl Massproduction (Q/Y)	Exemptions Used	Moisture Sensitivity Level	IPC/JEDEC-J-STD-020C compliant (Temp. Peak T _p in °C/ Time Peak t _p in sec/ Cycles)	Backward Compatibility	Product Change Notification No#./ Ref#	Product Change Notification Date
Axial TVS	GPP TVS P4KE, P6KE, 1.5KE - COMMERCIAL	VS	2/06	✓	✓	100% Sn matte	NONE	Cu	Standard P/N add "-E3"	NO	✓	✓	✓	Pb in HT solder DA, Pb in passivation glass	NA	NA	YES	39 Rev.4	Apr.28/06
Axial TVS	5KP - COMMERCIAL	VS	2/06	✓	✓	100% Sn matte	NONE	Cu	Standard P/N add "-E3"	NO	✓	✓	✓	Pb in HT solder DA, Pb in passivation glass	NA	NA	YES	39 Rev.4	Apr.28/06
Axial RECT	MPG06, SMPG06 - AUTOMOTIVE	VS	3/06	✓	✓	100% Sn matte	NONE	Cu	Standard P/N add "HE3"	YES	✓	✓	✓	Pb in HT solder DA, Pb in passivation glass	NA	NA	YES	39 Rev.4	Apr.28/06
Axial TVS	GPP TVS P4KE, P6KE, 1.5KE, PAR TVS, - AUTOMOTIVE	VS	3/06	✓	✓	100% Sn matte	NONE	Cu	Standard P/N add "HE3"	YES	✓	✓	✓	Pb in HT solder DA, Pb in passivation glass	NA	NA	YES	40 Rev.4	Apr.28/07
Axial RECT SUPER	GP/EGP - COMMERCIAL	VS	2/06	✓	✓	100% Sn matte	NONE	Cu	Standard P/N add "-E3"	NO	✓	✓	✓	Pb in HT solder DA, Pb in passivation glass	NA	NA	YES	41 Rev.4	Apr.28/08
Axial RECT SUPER	GP/EGP - AUTOMOTIVE	VS	3/06	✓	✓	100% Sn matte	NONE	Cu	Standard P/N add "HE3"	YES	✓	✓	✓	Pb in HT solder DA, Pb in passivation glass	NA	NA	YES	42 Rev.4	Apr.28/09
OPTO																			
LED leaded	TLXXXXXX	VS	✓	✓	✓	SnAg/Sn/Ag	g/Ag/N	Cu/Fe	Standard Part Number	NO	✓	✓	✓	None	NA	NA	✓	15/16	4/9/2003
LED SMD	TLMXXXXX	VS	✓	✓	✓	Sn	None	Cu/Fe	Standard Part Number	NO	✓	✓	✓	None	2	240/10/2	✓	15/16	4/9/2003
LED SMD	VLMxxxx	VS	✓	✓	✓	Sn	None	Cu/Fe	Standard Part Number	NO	✓	✓	✓	None	2a	260/peak/2	✓	NA	NA
Displays	TDSXXXXX	VS	✓	✓	✓	Ag	None	Cu/Fe	Standard Part Number	NO	✓	✓	✓	None	NA	NA	✓	15/16	4/9/2003
IR SMD	TEMXXXXX, TSMXXXXX	VS	✓	✓	✓	Sn	None	Cu/Fe	Standard Part Number	NO	✓	✓	✓	None	2	240/10/2	✓	15/16	4/9/2003
IR Receiver leaded	TSOP11XX-17XX, TSOP2XXX, TSOP311XX-317XX, TSOP4XXX, TSOP34XXX, TSOP7XXX, TSOP38XXX, TSOP58XXX, TSOP8XXX	VS	✓	✓	✓	Sn	Ag	Cu/Fe	Standard Part Number	NO	✓	✓	✓	None	NA	NA	✓	15/16	4/9/2003
IR Receiver SMD	TSOP61XX, TSOP62XX, TSOP361XX, TSOP362XX, TSOP5700, TSOP52XX	VS	✓	✓	✓	Sn	Ag	Cu/Fe	Standard Part Number	NO	✓	✓	✓	None	4	260/peak/2	✓	15/16	4/9/2003
IRDC - LF	TFDXXXXX,	VS	✓	✓	✓	Sn	Ag	Cu/Fe	Standard Part Number	NO	✓	✓	✓	None	4	260/peak/2	✓	15/16	4/9/2003
IRDC - PCB	TFBXXXXX	VS	✓	✓	✓	Au	Ni	PCB	Standard Part Number	NO	✓	✓	✓	None	4	260/peak/2	✓	15/16	4/9/2003
IR LED-DET leaded-1,8/3	TSXXXXXX, TESTXXXX, TEFTXXXX	VS	✓	✓	✓	SnAg/Sn/Ag	g/Ag/N	Cu/Fe	Standard Part Number	NO	✓	✓	✓	None	NA	NA	✓	15/16	4/9/2003
Side view lens	TEKSXXXX, TSKSXXXX	VS	✓	✓	✓	Sn	Ag	Cu/Fe	Standard Part Number	NO	✓	✓	✓	None	NA	NA	✓	15/16	4/9/2003
Coupler&SSR SMD	TCMTXXXX, TCLTXXXX, Miniflat, Flatpack, SO8, SFHXXXX	VS	✓	✓	✓	Sn	None	Cu/Fe	Standard Part Number	NO	✓	✓	✓	None	1	260/peak/2	✓	15/16 /43	09.04.2003 04.12.2003
Coupler&SSR leaded	SFHXXX, TCETXXXX, TCdTXXXX, DIP4/8/16, DIP6	VS	✓	✓	✓	Sn	None	Cu/Fe	Standard Part Number	NO	✓	✓	✓	None	NA	NA	✓	15/16 /43	2003 04.12.2003
Sensor Assy	TCSTXXXX, TCRTXXXX	VS	✓	✓	✓	SnAg/Sn/Ag	g/Ag/N	Cu/Fe	Standard Part Number	NO	✓	✓	✓	None	NA	NA	✓	15/16	4/9/2003

Notes:

- Please contact your local Vishay Sales Office
- ✓ indicates that the item is complete or compliant. If product is complete/compliant less than a year the actual date is shown.
- NA indicates that the item is not applicable (i.e. not converting to Pb-Free)
- SI=Siliconix, VS=Vishay Semiconductors

This Document is subjected to change without notice