

APPROVAL SHEET

RFBPF 2520(1008) Series – RoHS Compliance
MULTILAYER CERAMIC BAND PASS FILTER

2.4 GHz ISM Band Working Frequency

P/N: RFBPF2520120A2T

*Contents in this sheet are subject to change without prior notice.

FEATURES

1. Multilayer LTCC (Low Temperature Cofired Ceramics) Technology
2. Reflow solderable
3. Miniatured Size 2.5 x 2.0 x 1.2 mm³
4. Low Insertion Loss
5. High attenuation on 2nd and 3rd harmonic suppressed
6. Suitable for 2.45 GHz Working Frequency Operation

APPLICATIONS

1. 2.4GHz ISM Band RF Application
2. Bluetooth, Wireless LAN, HomeRF

CONSTRUCTION

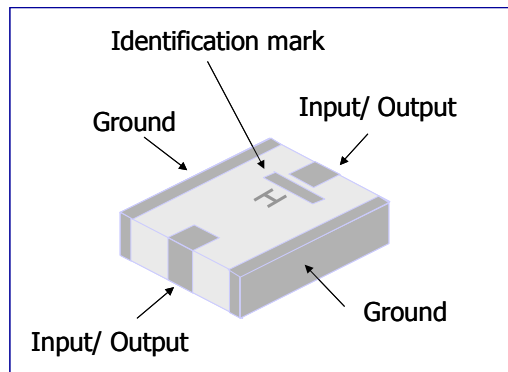

Fig 1. Outline of 2.4GHz Band Pass Filter 2520 size

DESCRIPTION

Walsin Technology Corporation develops a new ceramic Band Pass Filter specified for 2.4 GHz ISM Band application, as shown in fig-1. Both of Wireless LAN IEEE 802.11b/g/n, and Bluetooth™ typically located on this unlicensed frequency band which range covers from 2.4GHz to 2.4835GHz. To fulfil the in-band and out-band frequency requirements, this Band Pass Filter has been designed to a high suppression on 2nd harmonic as well as low insertion loss characteristics through Walsin's advanced LTCC (Low Temperature Co-fired Ceramic) technology and superior product design via 3D EM Simulation Skill.

This Band Pass Filter has a rectangular ceramic body with a tiny dimension of 2.5 x 2.0 x 1.2 mm³ future meet the SMT automation and miniaturization requirements on modern portable devices.

DIMENSIONS

Figure	Symbol	Dimension
	L	2.50 ± 0.20 mm
	W	2.00 ± 0.20 mm
	T	1.20 ± 0.10 mm
	A	0.25 ± 0.20 mm
	B	0.50 ± 0.20 mm
	C	0.50 ± 0.20 mm

ELECTRICAL CHARACTERISTICS

RFBPF2520120A2T	Specification
Frequency range	2450 ± 50 MHz
Insertion Loss	2.1 dB max
VSWR	2.0 max
Impedance	50 Ω
Operation Temperature Range	-40°C ~ +85°C
Attenuation (min.)	30dB @ 900MHz 30dB @ 1850 MHz 30dB @ 4800 MHz

Typical Electrical Chart

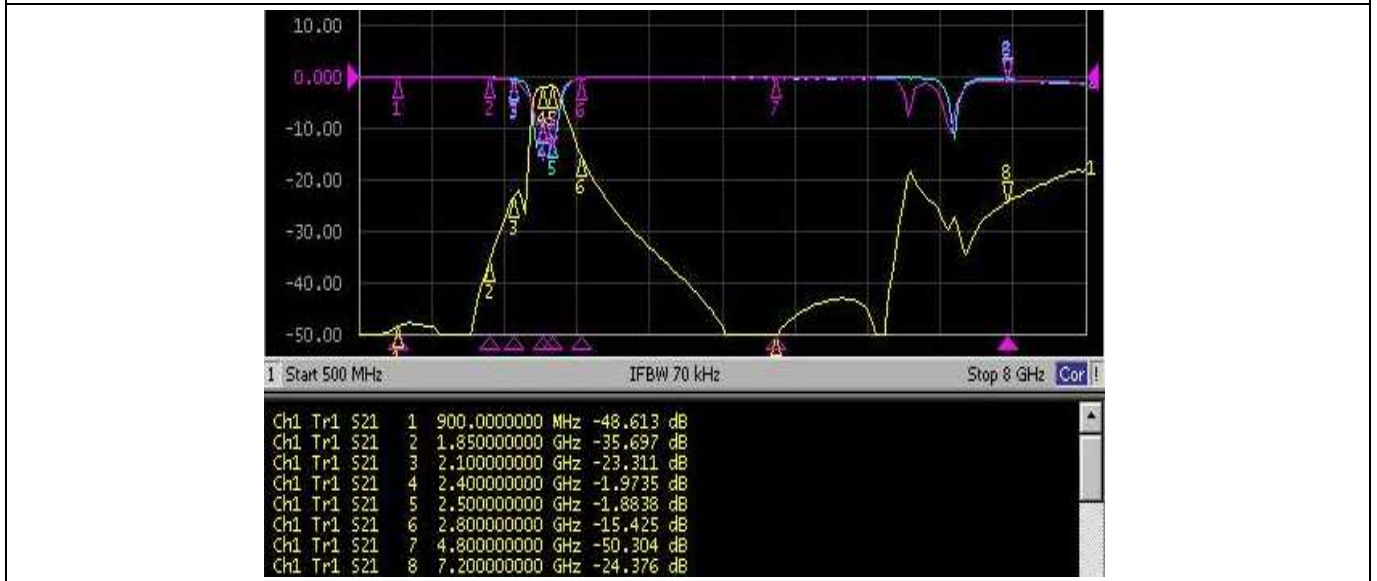

SOLDER LAND PATTERN

Figure	Symbol	Dimension (mm)
<p>Line width to be design to match 50Ω characteristic impedance, depending on PCB material and thickness . Φ are the grounding through holes.</p>	L1	2.50 ± 0.10
	L2	0.70 ± 0.10
	L3	0.58 ± 0.05
	W1	0.75 ± 0.05
	W2	1.00 ± 0.10
	S1	0.38 ± 0.05
	S2	0.23 ± 0.05
	S3	0.60 ± 0.05
	S4	0.90 ± 0.05
	S5	1.25 ± 0.05
	Φ	0.40 ± 0.10

RELIABILITY TEST

Test item	Test condition / Test method	Specification
Solderability JIS C 0050-4.6 JESD22-B102D	*Solder bath temperature : $235 \pm 5^{\circ}\text{C}$ *Immersion time : 2 ± 0.5 sec *Solder : Sn3Ag0.5Cu for lead-free	At least 95% of a surface of each terminal electrode must be covered by fresh solder.
Leaching (Resistance to dissolution of metallization) IEC 60068-2-58	*Solder bath temperature : $260 \pm 5^{\circ}\text{C}$ *Leaching immersion time : 30 ± 0.5 sec *Solder : SN63A	Loss of metallization on the edges of each electrode shall not exceed 25%.
Resistance to soldering heat JIS C 0050-5.4	*Preheating temperature : $120\sim 150^{\circ}\text{C}$, 1 minute. *Solder temperature : $270\pm 5^{\circ}\text{C}$ *Immersion time : 10 ± 1 sec *Solder : Sn3Ag0.5Cu for lead-free Measurement to be made after keeping at room temperature for 24 ± 2 hrs	No mechanical damage. Samples shall satisfy electrical specification after test. Loss of metallization on the edges of each electrode shall not exceed 25%.
Drop Test JIS C 0044	*Height : 75 cm *Test Surface : Rigid surface of concrete or steel. *Times : 6 surfaces for each units : 2 times for each side.	No mechanical damage. Samples shall satisfy electrical specification after test.
Adhesive Strength of Termination JIS C 0051- 7.4.3	*Pressurizing force : $5\text{N}(\leq 0603)$; $10\text{N}(>0603)$ *Test time : 10 ± 1 sec	No remarkable damage or removal of the termination.
Bending test JIS C 0051- 7.4.1	The middle part of substrate shall be pressurized by means of the pressurizing rod at a rate of about 1 mm/s per second until the deflection becomes 1mm/s and then pressure shall be maintained for 5 ± 1 sec. Measurement to be made after keeping at room temperature for 24 ± 2 hours	No mechanical damage. Samples shall satisfy electrical specification after test.

Approval sheet

Temperature cycle JIS C 0025	<ol style="list-style-type: none"> 1. 30±3 minutes at -40°C±3°C, 2. 10~15 minutes at room temperature, 3. 30±3 minutes at +85°C±3°C, 4. 10~15 minutes at room temperature, Total 100 continuous cycles Measurement to be made after keeping at room temperature for 24±2 hrs	No mechanical damage. Samples shall satisfy electrical specification after test.
Vibration JIS C 0040	*Frequency : 10Hz~55Hz~10Hz(1min) *Total amplitude : 1.5mm *Test times : 6hrs.(Two hrs each in three mutually perpendicular directions)	No mechanical damage. Samples shall satisfy electrical specification after test.
High temperature JIS C 0021	*Temperature : 85°C±2°C *Test duration : 1000+24/-0 hours Measurement to be made after keeping at room temperature for 24±2 hrs	No mechanical damage. Samples shall satisfy electrical specification after test.
Humidity (steady conditions) JIS C 0022	*Humidity : 90% to 95% R.H. *Temperature : 40±2°C *Time : 1000+24/-0 hrs. Measurement to be made after keeping at room temperature for 24±2 hrs ※ 500hrs measuring the first data then 1000hrs data	No mechanical damage. Samples shall satisfy electrical specification after test.
Low temperature JIS C 0020	*Temperature : -40°C±2°C *Test duration : 1000+24/-0 hours Measurement to be made after keeping at room temperature for 24±2 hrs	No mechanical damage. Samples shall satisfy electrical specification after test.

SOLDERING CONDITION

Typical examples of soldering processes that provide reliable joints without any damage are given in Fig 2,

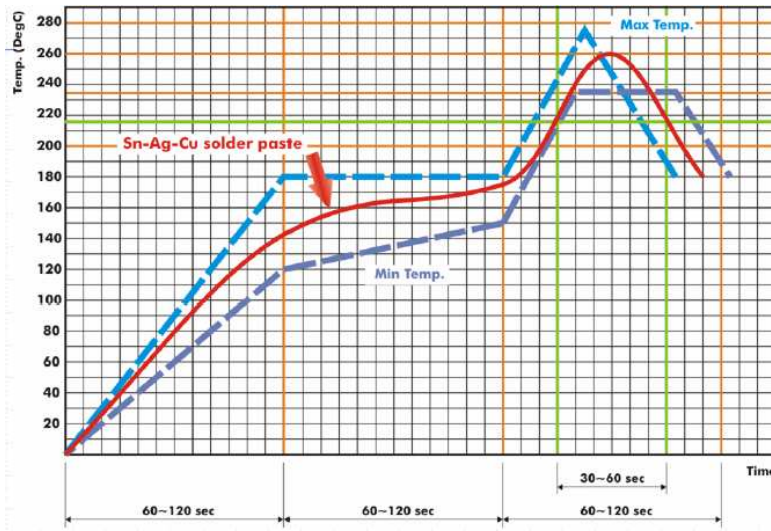

Fig 2. Infrared soldering profile

ORDERING CODE

RF	BPF	252012	0	A	2	T
Walsin RF Pb free device	Product Code BPF : Band Pass Filter	Dimension code Per 2 digits of Length, Width, Thickness : e.g. : 252012 = Length 25, Width 20, Thickness 12	Unit of dimension 0 : 0.1 mm 1 : 1.0 mm	Application A : 2.4GHZ ISM Band	Specification Design Code	Packing T : Reeled

Minimum Ordering Quantity: 2000 pcs per reel.

PACKAGING

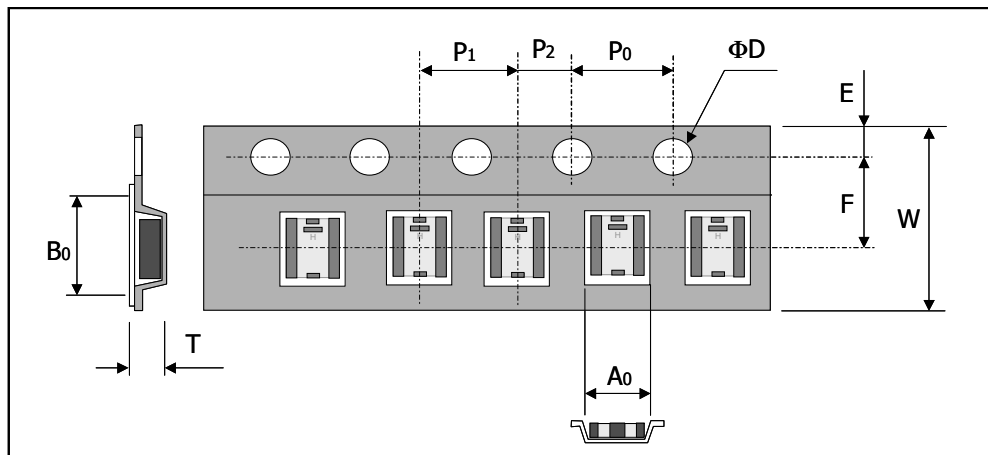

Plastic Tape specifications (unit :mm)

Index	Ao	Bo	ΦD	T	W
Dimension (mm)	2.40 ± 0.10	2.95 ± 0.10	1.55 ± 0.05	1.45 ± 0.10	8.00 ± 0.10
Index	E	F	Po	P1	P2
Dimension (mm)	1.75± 0.10	3.50 ± 0.10	4.00 ± 0.20	4.00 ± 0.10	2.00± 0.10

Reel dimensions

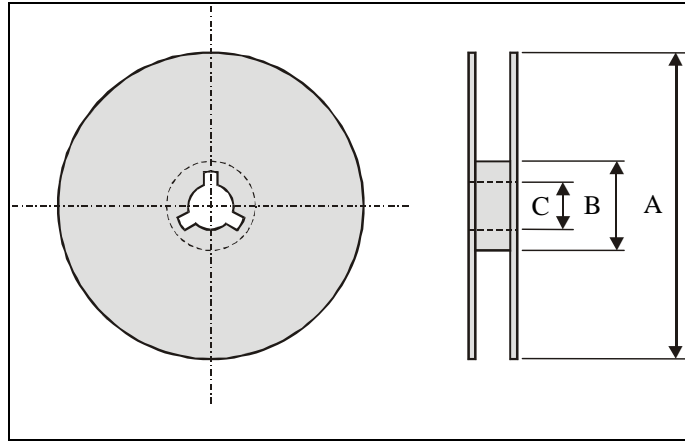

Index	A	B	C
Dimension (mm)	Φ178.0	Φ60.0	Φ13.0

Taping Quantity:2000 pieces per 7" reel

CAUTION OF HANDLING

Limitation of Applications

Please contact us before using our products for the applications listed below which require especially high reliability for the prevention of defects, which might directly cause damage to the third party's life, body or property.

- (1) Aircraft equipment
- (2) Aerospace equipment
- (3) Undersea equipment
- (4) Medical equipment
- (5) Disaster prevention / crime prevention equipment
- (6) Traffic signal equipment
- (7) Transportation equipment (vehicles, trains, ships, etc.)
- (8) Applications of similar complexity and /or reliability requirements to the applications listed in the above.

Storage condition

- (1) Products should be used in 6 months from the day of WALSIN outgoing inspection, which can be confirmed.
- (2) Storage environment condition.
 - Products should be storage in the warehouse on the following conditions.
 - Temperature : -10 to +40°C
 - Humidity : 30 to 70% relative humidity
 - Don't keep products in corrosive gases such as sulfur. Chlorine gas or acid or it may cause oxidization of electrode, resulting in poor solderability.
 - Products should be storage on the palette for the prevention of the influence from humidity, dust and son on.
 - Products should be storage in the warehouse without heat shock, vibration, direct sunlight and so on.
 - Products should be storage under the airtight packaged condition.