



Features

1. Normally open, single pole, single throw.
2. Control 400VAC or DC voltage.
3. Switch 130mA loads.
4. LED control current, 5mA.
5. Low ON-resistance.
6. dv/dt , >500V/mS.
7. Isolation test voltage, 3750V_{RMS}.

Part Numbering System & Part Marking System: Page 3 & 4.

Absolute Maximum Ratings

(Ta=25°C)

Emitter (Input)	Detector (Output)
Reverse Voltage.....5.0V	Output Breakdown Voltage±400V
Continuous Forward Current50mA	Continuous Load Current±130mA
Peak Forward Current1A	Power Dissipation500mW
Power Dissipation100mW	
Derate Linearly from 25°C1.3mW/°C	

General Characteristics

Isolation Test Voltage.....3750V _{RMS}	Storage Temperature Range-40°C to +125°C
Isolation Resistance	Operating Temperature Range...-30°C to +85°C
V _{IO} = 500V, T _A = 25°C≥10 ¹⁰ Ω	Junction Temperature.....100°C
Total Power Dissipation550mW	Soldering Temperature,
Derate Linearly from 25°C2.5mW/°C	2mm from case, 10 sec260°C

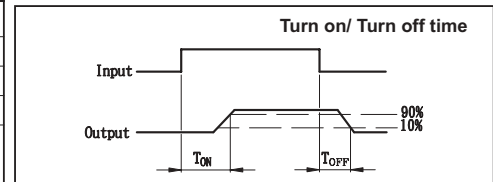
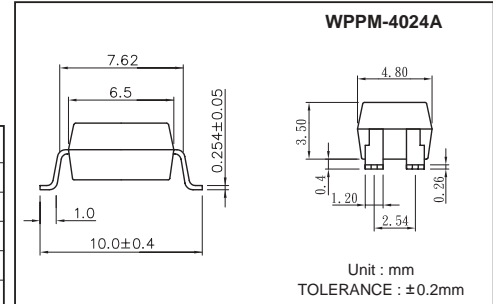
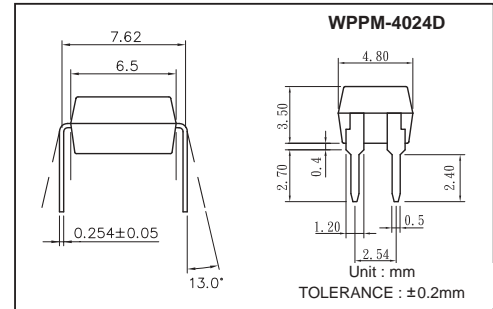

Electro-optical Characteristics

(Ta=25°C)

Parameter	Symbol	Conditions	Min.	Typ.	Max.	Unit
Emitter (Input)						
Forward Voltage	V _F	I _F = 10mA		1.2	1.5	V
Operation Input Current	I _{OFF}	V _L = ±20V, I _L ≤ 5uA			5	mA
Recovery Input Current	I _{FON}	V _L = ±20V, I _L = 100mA, t = 10mS	0.2			mA
Detector (Output)						
Output Breakdown Voltage	V _B	I _B = 50uA	400			V
Output Off-State Leakage	I _{TOFF}	V _T = 100V, I _F = 0mA		0.2	1	uA
I/O Capacitance	C _{ISO}	I _F = 0, f = 1MHz		6		pF
ON Resistance	R _{ON}	I _L = 100mA, I _F = 10mA		20	30	Ω
Turn-On Time	T _{ON}	I _F = 10mA, V _L = ±20V		0.3	1.0	mS
Turn-Off Time	T _{OFF}	t = 10mS, I _L = ±100mA		0.7	1.5	mS

MOS Relay Schematic and Wiring Diagrams

Type	Schematic	Output configuration	Load	Connection	Wiring Diagrams
4024D & 4024A		1a	AC/DC	-	

Data Curve

