

DATA SHEET

THICK FILM CHIP RESISTORS
Automotive grade

AC series

5%, 1%

sizes 0402/0603/0805/1206/
1210/1218/2010/2512

RoHS compliant & Halogen free



SCOPE

This specification describes AC0402 to AC2512 chip resistors with lead-free terminations made by thick film process.

APPLICATIONS

- All general purpose applications
- Car electronics, industrial application

FEATURES

- Comply with AEC-Q200 standard
- Superior resistance against sulfur containing atmosphere
- MSL class: MSL 1
- AC series soldering is compliant with J-STD-020D
- Halogen free epoxy
- RoHS compliant
 - Products with lead-free terminations meet RoHS requirements
 - Pb-glass contained in electrodes, resistor element and glass are exempted by RoHS
- Reduce environmentally hazardous waste
- High component and equipment reliability
- Save PCB space
- The resistors are 100% performed by automatic optical inspection prior to taping.

ORDERING INFORMATION - GLOBAL PART NUMBER

Part number is identified by the series name, size, tolerance, packaging type, temperature coefficient, taping reel and resistance value.

GLOBAL PART NUMBER

AC XXXX X X X XX XXXX L
 (1) (2) (3) (4) (5) (6) (7)

(1) SIZE

0402 / 0603 / 0805 / 1206 / 1210 / 1218 / 2010 / 2512

(2) TOLERANCE

F = ±1%
 J = ±5%

(3) PACKAGING TYPE

R = Paper/PE taping reel K = Embossed taping reel

(4) TEMPERATURE COEFFICIENT OF RESISTANCE

- = Base on spec

(5) TAPING REEL

07 = 7 inch dia. Reel 10 = 10 inch dia. Reel
 13 = 13 inch dia. Reel 7D = 7 inch dia. Reel with double quantity

(6) RESISTANCE VALUE

1Ω to 10 MΩ
 There are 2~4 digits indicated the resistance value. Letter R/K/M is decimal point, no need to mention the last zero after R/K/M, e.g. 1K2, not 1K20.
 Detailed coding rules of resistance are shown in the table of "Resistance rule of global part number".

(7) DEFAULT CODE

Letter L is the system default code for ordering only. (Note)

Resistance rule of global part number	
Resistance coding rule	Example
0RXXX (1 to 976 mΩ)	0R1 = 0.1 Ω 0R12 = 0.12 Ω 0R105 = 0.105 Ω
XRXX (1 to 9.76 Ω)	1R = 1 Ω 1R5 = 1.5 Ω 9R76 = 9.76 Ω
XXRX (10 to 97.6 Ω)	10R = 10 Ω 97R6 = 97.6 Ω
XXXR (100 to 976 Ω)	100R = 100 Ω
XKXX (1 to 9.76 KΩ)	1K = 1,000 Ω 9K76 = 9760 Ω
XMXX (1 to 9.76 MΩ)	1M = 1,000,000 Ω 9M76 = 9,760,000 Ω

ORDERING EXAMPLE

The ordering code for an AC0402 chip resistor, value 100 KΩ with ±1% tolerance, supplied in 7-inch tape reel is: AC0402FR-07100KL.

NOTE

1. All our RSMD products are RoHS compliant and Halogen free. "LFP" of the internal 2D reel label states "Lead-Free Process".
2. On customized label, "LFP" or specific symbol can be printed.
3. Suitable and limited to non-safety related applications.
4. AC series with ±0.5% tolerance is also available. For further information, please contact sales.

MARKING

AC0402



No marking

Fig. 1

AC0603 / AC0805 / AC1206 / AC1210 / AC1218 / AC2010 / AC2512

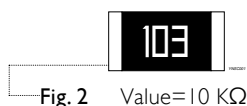

E-24 series: 3 digits, $\pm 5\%$
 First two digits for significant figure and 3rd digit for number of zeros

Fig. 2 Value = 10 K Ω

AC0603



E-24 series: 3 digits, $\pm 1\%$
 One short bar under marking letter

Fig. 3 Value = 24 Ω



E-96 series: 3 digits, $\pm 1\%$
 First two digits for E-96 marking rule and 3rd letter for number of zeros

Fig. 4 Value = 12.4 K Ω

AC0805 / AC1206 / AC1210 / AC1218 / AC2010 / AC2512

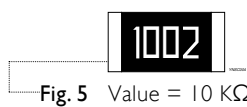

Both E-24 and E-96 series: 4 digits, $\pm 1\%$
 First three digits for significant figure and 4th digit for number of zeros

Fig. 5 Value = 10 K Ω

NOTE

For further marking information, please refer to data sheet "Chip resistors marking". Marking of AC series is the same as RC series.

CONSTRUCTION

The resistors are constructed on top of an automotive grade ceramic body. Internal metal electrodes are added at each end and connected by a resistive glaze. The resistive glaze is covered by a lead-free glass. The composition of the glaze is adjusted to give the approximately required resistance value and laser trimming of this resistive glaze achieves the value within tolerance. The whole element is covered by a protective overcoat. Size 0603 and bigger is marked with the resistance value on top. Finally, the two external terminations (Ni / matte tin) are added, as shown in Fig.6.

DIMENSIONS

Table 1 For outlines, please refer to Fig. 6

TYPE	L (mm)	W (mm)	H (mm)	l ₁ (mm)	l ₂ (mm)
AC0402	1.00 ±0.05	0.50 ±0.05	0.32 ±0.05	0.20 ±0.10	0.25 ±0.10
AC0603	1.60 ±0.10	0.80 ±0.10	0.45 ±0.10	0.25 ±0.15	0.25 ±0.15
AC0805	2.00 ±0.10	1.25 ±0.10	0.50 ±0.10	0.35 ±0.20	0.35 ±0.20
AC1206	3.10 ±0.10	1.60 ±0.10	0.55 ±0.10	0.45 ±0.20	0.40 ±0.20
AC1210	3.10 ±0.10	2.60 ±0.15	0.50 ±0.10	0.45 ±0.15	0.50 ±0.20
AC1218	3.10 ±0.10	4.60 ±0.10	0.55 ±0.10	0.45 ±0.20	0.40 ±0.20
AC2010	5.00 ±0.10	2.50 ±0.15	0.55 ±0.10	0.55 ±0.15	0.50 ±0.20
AC2512	6.35 ±0.10	3.10 ±0.15	0.55 ±0.10	0.60 ±0.20	0.50 ±0.20

OUTLINES

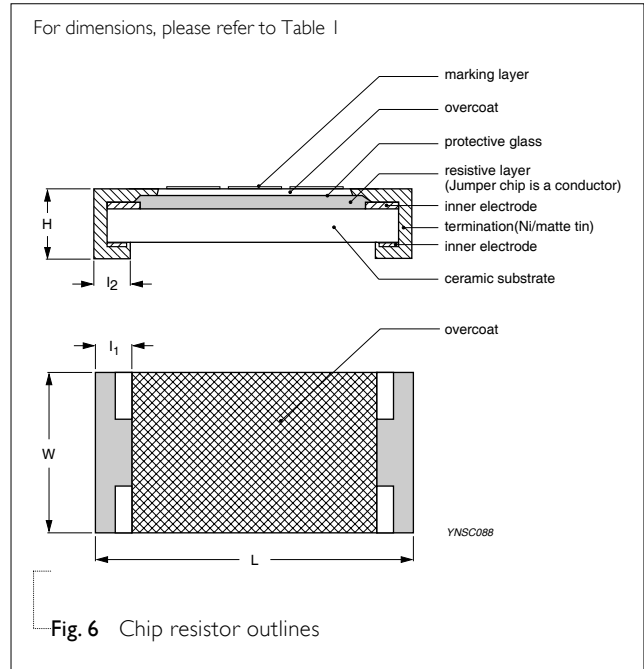

Fig. 6 Chip resistor outlines

ELECTRICAL CHARACTERISTICS

Table 2

TYPE	RESISTANCE RANGE	CHARACTERISTICS				Temperature Coefficient of Resistance
		Operating Temperature Range	Max. Working Voltage	Max. Overload Voltage	Dielectric Withstanding Voltage	
AC0402			50 V	100 V	100 V	
AC0603			50 V	100 V	100 V	
AC0805			150 V	300 V	300 V	
AC1206	1%, 5% 1 Ω to 10 MΩ	-55 °C to +155 °C	200 V	400 V	500 V	1 Ω ≤ R ≤ 10 Ω, ±200 ppm/°C
AC1210	Zero Ohm Jumper < 0.05 Ω		200 V	500 V	500 V	10 Ω < R ≤ 10 MΩ, ±100 ppm/°C
AC1218			200 V	500 V	500 V	
AC2010			200 V	500 V	500 V	
AC2512			200 V	500 V	500 V	

FOOTPRINT AND SOLDERING PROFILES

Recommended footprint and soldering profiles of AC-series is the same as RC-series. Please refer to data sheet “Chip resistors mounting”.

PACKING STYLE AND PACKAGING QUANTITY

Table 3 Packing style and packaging quantity

PACKING STYLE	REEL DIMENSION	AC0402	AC0603	AC0805	AC1206	AC1210	AC1218	AC2010	AC2512
Paper/PE taping reel (R)	7" (178 mm)	10,000 20,000	5,000	5,000	5,000	5,000	---	---	---
	10" (254 mm)	20,000	10,000	10,000	10,000	---	---	---	---
	13" (330 mm)	50,000	20,000	20,000	20,000	20,000	---	---	---
Embossed taping reel (K)	7" (178 mm)	---	---	---	---	---	4,000	4,000	4,000

NOTE

I. For paper/PE/embossed tape and reel specifications/dimensions, please refer to data sheet “Chip resistors packing”.

FUNCTIONAL DESCRIPTION

OPERATING TEMPERATURE RANGE

Range: -55 °C to +155 °C

POWER RATING

Each type rated power at 70 °C:

- AC0402=1/16 W(0.0625W)
- AC0603=1/10 W(0.1W)
- AC0805=1/8 W(0.125W)
- AC1206=1/4 W(0.25W)
- AC1210=1/2 W(0.5W)
- AC1218=1 W
- AC2010=3/4 W(0.75W)
- AC2512=1 W

RATED VOLTAGE

The DC or AC (rms) continuous working voltage corresponding to the rated power is determined by the following formula:

$$V = \sqrt{P \times R}$$

Where

V = Continuous rated DC or AC (rms) working voltage (V)

P = Rated power (W)

R = Resistance value (Ω)

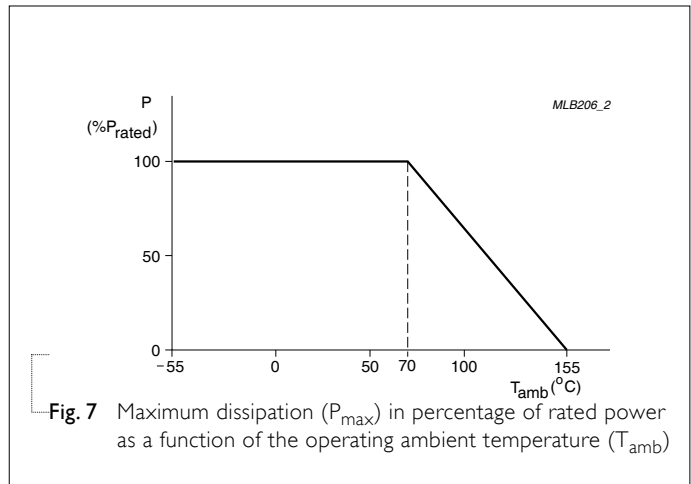

Fig. 7 Maximum dissipation (P_{max}) in percentage of rated power as a function of the operating ambient temperature (T_{amb})

TESTS AND REQUIREMENTS
Table 4 Test condition, procedure and requirements

TEST	TEST METHOD	PROCEDURE	REQUIREMENTS
High Temperature Exposure	AEC-Q200 Test 3 MIL-STD-202 Method 108	1,000 hours at $T_A = 125\text{ }^\circ\text{C}$, unpowered	$\pm(1.0\%+0.05\ \Omega)$
Moisture Resistance	AEC-Q200 Test 6 MIL-STD-202 Method 106	Each temperature / humidity cycle is defined at 8 hours (method 106F), 3 cycles / 24 hours for 10d. with $25\text{ }^\circ\text{C}$ / $65\text{ }^\circ\text{C}$ 95% R.H, without steps 7a & 7b, unpowered Parts mounted on test-boards, without condensation on parts	$\pm(0.5\%+0.05\ \Omega)$ for 1% tol. $\pm(2.0\%+0.05\ \Omega)$ for 5% tol. < 100 m Ω for Jumper
Biased Humidity	AEC-Q200 Test 7 MIL-STD-202 Method 103	1,000 hours; $85\text{ }^\circ\text{C}$ / 85% RH 10% of operating power Measurement at 24 ± 4 hours after test conclusion.	$\pm(1.0\%+0.05\ \Omega)$
Operational Life	AEC-Q200 Test 8 MIL-STD-202 Method 108	1,000 hours at $125\text{ }^\circ\text{C}$, derated voltage applied for 1.5 hours on, 0.5 hour off, still-air required	$\pm(1.0\%+0.05\ \Omega)$
Resistance to Soldering Heat	AEC-Q200 Test 15 MIL-STD-202 Method 210	Condition B, no pre-heat of samples Lead-free solder, $260\pm 5\text{ }^\circ\text{C}$, 10 ± 1 seconds immersion time Procedure 2 for SMD: devices fluxed and cleaned with isopropanol	$\pm(1.0\%+0.05\ \Omega)$ No visible damage
Thermal Shock	AEC-Q200 Test 16 MIL-STD-202 Method 107	$-55/+125\text{ }^\circ\text{C}$ Number of cycles is 300. Devices mounted Maximum transfer time is 20 seconds. Dwell time is 15 minutes. Air – Air	$\pm(1.0\%+0.05\ \Omega)$
ESD	AEC-Q200 Test 17 AEC-Q200-002	Human Body Model, 1 pos. + 1 neg. discharges 0402/0603: 1 KV, 0805 and above: 2 KV	$\pm(3.0\%+0.05\ \Omega)$

TEST	TEST METHOD	PROCEDURE	REQUIREMENTS
Solderability - Wetting	AEC-Q200 Test 18 J-STD-002	Electrical Test not required Magnification 50X SMD conditions: (a) Method B, aging 4 hours at 155 °C dry heat, dipping at 235±3 °C for 5±0.5 seconds. (b) Method B, steam aging 8 hours, dipping at 215±3 °C for 5±0.5 seconds. (c) Method D, steam aging 8 hours, dipping at 260±3 °C for 7±0.5 seconds.	Well tinned (≥95% covered) No visible damage
Board Flex	AEC-Q200 Test 21 AEC-Q200-005	Chips mounted on a 90mm glass epoxy resin PCB (FR4) Bending for 0402: 5 mm 0603/0805: 3 mm 1206 and above: 2 mm Holding time: minimum 60 seconds	±(1.0%+0.05 Ω)
Terminal Strength	AEC-Q200 Test 22 AEC-Q200-006	Force of 10N for 0402, and 17.7N for 0603 and above. The force applied for 60±1 seconds.	±(1.0%+0.05 Ω)
Temperature Coefficient of Resistance (T.C.R.)	IEC 60115-1 4.8	At +25/-55 °C and +25/+125 °C Formula: $T.C.R = \frac{R_2 - R_1}{R_1(t_2 - t_1)} \times 10^6 \text{ (ppm/°C)}$ Where t ₁ =+25 °C or specified room temperature t ₂ =-55 °C or +125 °C test temperature R ₁ =resistance at reference temperature in ohms R ₂ =resistance at test temperature in ohms	Refer to table 2
Short Time Overload	IEC60115-1 4.13	2.5 times of rated voltage or maximum overload voltage whichever is less for 5 sec at room temperature	±(1.0%+0.05 Ω)

REVISION HISTORY

REVISION	DATE	CHANGE NOTIFICATION	DESCRIPTION
Version 1	Feb. 01, 2011	-	- Case size 1210, 1218, 2010, 2512 extended - Test method and procedure updated - Packing style of 7D added
Version 0	Nov. 10, 2010	-	- First issue of this specification

“ Yageo reserves all the rights for revising the content of this datasheet without further notification, as long as the products are unchanged. Any product change will be announced by PCN.”

"The reimbursement is limited to the value of the products."