

WINSTAR Display

OLED SPECIFICATION

Model No:

WEP002002A

General Specification

Item	Dimension	Unit
Number of Characters	20 Characters x 2 Lines	—
Module dimension	92.3 x 23.3 x 7 Max.	mm
Active area	73.52 x 11.52	mm
Dot size	0.62 x 0.67	mm
Dot pitch	0.65 x 0.70	mm
Character size	3.22 x 5.57	mm
Character pitch	3.70 x 5.95	mm
LCD type	OLED , Monochrome	
Duty	1/16	
IC	SSD1311	
Interface	6800,8080,SPI,I2C	
Size	2.93 inch	

Contour Drawing & Block Diagram

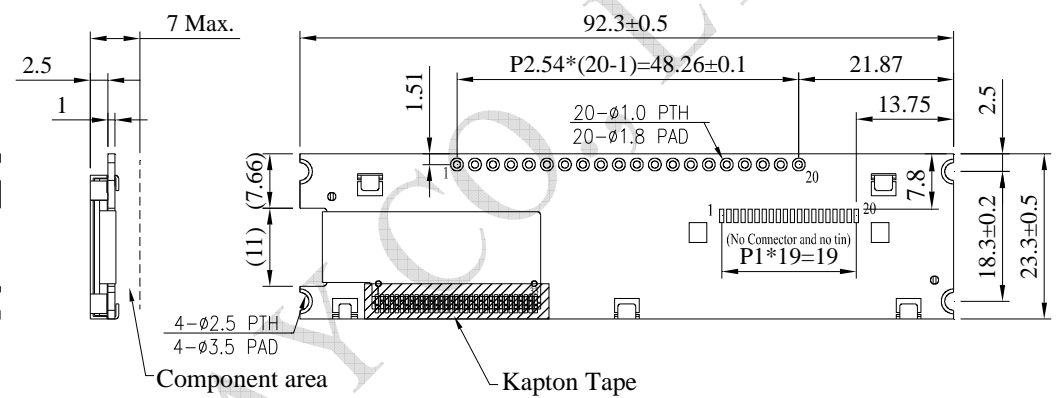
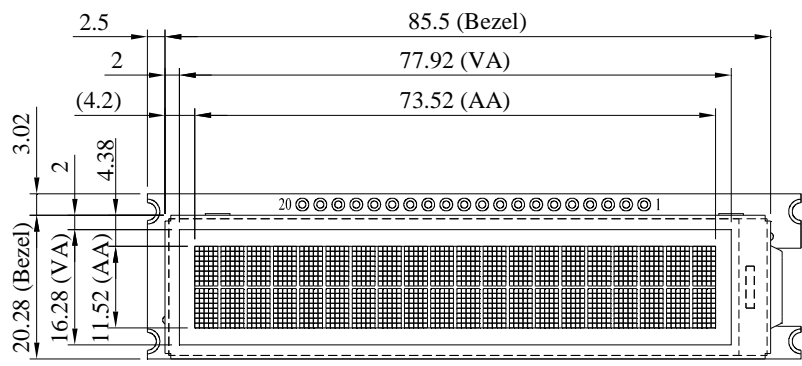

PIN	SYMBOL	PIN	SYMBOL
1	VSS	11	D4
2	VDD	12	D5
3	REGVDD	13	D6
4	D/C#	14	D7
5	R/W#	15	CS#
6	E	16	RES#
7	D0	17	BS0
8	D1	18	BS1
9	D2	19	BS2
10	D3	20	VSS

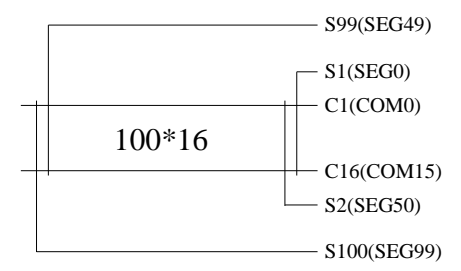
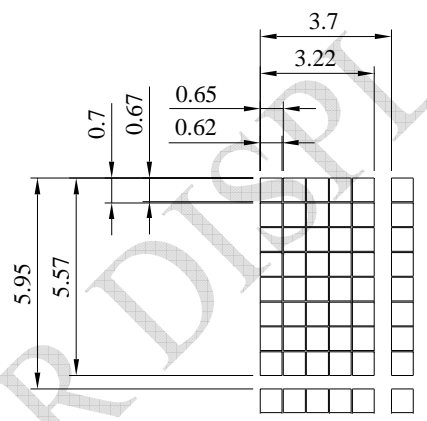

The non-specified tolerance of dimension is $\pm 0.3\text{mm}$.

Interface Pin Function

Pin No.	Symbol	Pin Type	Description
1	VSS	P	Ground pin. It must be connected to external ground.
2	VDD	P	Power supply for core logic operation. A capacitor should be connected between VDD and VSS under all circumstances.
3	REGVDD	I	Internal VDD regulator selection pin It must be connected to external ground.
4	D/C#	I	This pin is Data/Command control pin connecting to the MCU. When the pin is pulled HIGH, the data at D[7:0] will be interpreted as data. When the pin is pulled LOW, the data at D[7:0] will be transferred to a command register. In I2C mode, this pin acts as SA0 for slave address selection. When serial interface is selected, this pin must be connected to VSS.
5	R/W#	I	This pin is read / write control input pin connecting to the MCU interface. When 6800 interface mode is selected, this pin will be used as Read/Write (R/W#) selection input. Read mode will be carried out when this pin is pulled HIGH and write mode when LOW. When 8080 interface mode is selected, this pin will be the Write (WR#) input. Data write operation is initiated when this pin is pulled LOW and the chip is selected. When serial or I2C interface is selected, this pin must be connected to VSS.
6	E	I	This pin is MCU interface input. When 6800 interface mode is selected, this pin will be used as the Enable (E) signal. Read/write operation is initiated when this pin is pulled HIGH and the chip is selected. When 8080 interface mode is selected, this pin receives the Read (RD#) signal. Read operation is initiated when this pin is pulled LOW and the chip is selected. When serial or I2C interface is selected, this pin must be connected to VSS.

7	D0	I/O	<p>These pins are bi-directional data bus connecting to the MCU data bus.</p> <p>Unused pins are recommended to tie LOW.</p> <p>When serial interface mode is selected, D0 will be the serial clock input: SCLK; D1 will be the serial data input: SID and D2 will be the serial data output: SOD.</p> <p>When I2C mode is selected, D2, D1 should be tied together and serve as SDAout, SDAin in application and D0 is the serial clock input, SCL.</p>																		
8	D1																				
9	D2																				
10	D3																				
11	D4																				
12	D5																				
13	D6																				
14	D7																				
15	CS#	I	<p>This pin is the chip select input connecting to the MCU.</p> <p>The chip is enabled for MCU communication only when CS# is pulled LOW (active LOW).</p> <p>In I2C mode, this pin must be connected to VSS.</p>																		
16	RES#	I	<p>This pin is reset signal input.</p> <p>When the pin is pulled LOW, initialization of the chip is executed.</p> <p>Keep this pin pull HIGH during normal operation.</p>																		
17	BS0	I	<p>MCU bus interface selection pins. Select appropriate logic setting as described in the following table. BS2, BS1 and BS0 are pin select.</p> <p>Bus Interface selection</p> <table border="1"> <thead> <tr> <th>BS[2:0]</th> <th>Interface</th> </tr> </thead> <tbody> <tr> <td>000</td> <td>Serial Interface</td> </tr> <tr> <td>001</td> <td>Invalid</td> </tr> <tr> <td>010</td> <td>I²C</td> </tr> <tr> <td>011</td> <td>Invalid</td> </tr> <tr> <td>100</td> <td>8-bit 6800 parallel</td> </tr> <tr> <td>101</td> <td>4-bit 6800 parallel</td> </tr> <tr> <td>110</td> <td>8-bit 8080 parallel</td> </tr> <tr> <td>111</td> <td>4-bit 8080 parallel</td> </tr> </tbody> </table> <p>Note (1) 0 is connected to VSS (2) 1 is connected to VDD</p>	BS[2:0]	Interface	000	Serial Interface	001	Invalid	010	I ² C	011	Invalid	100	8-bit 6800 parallel	101	4-bit 6800 parallel	110	8-bit 8080 parallel	111	4-bit 8080 parallel
BS[2:0]	Interface																				
000	Serial Interface																				
001	Invalid																				
010	I ² C																				
011	Invalid																				
100	8-bit 6800 parallel																				
101	4-bit 6800 parallel																				
110	8-bit 8080 parallel																				
111	4-bit 8080 parallel																				
18	BS1																				
19	BS2																				
20	VSS	P	Ground pin. It must be connected to external ground.																		

Absolute Maximum Ratings

Item	Symbol	Min	Max	Unit
Supply Voltage For Logic	VDD-VSS	-0.3	3.6	V
Operating Temperature	TOP	-40	+80	°C
Storage Temperature	TST	-40	+85	°C

Electrical Characteristics

DC Electrical Characteristics

Item	Symbol	Condition	Min	Typ	Max	Unit
Supply Voltage For Logic	VDD-VSS	—	3.1	3.3	3.5	V
Input High Volt.	VIH	—	0.8xVDD	—	—	V
Input Low Volt.	VIL	—	—	—	0.2xVDD	V
Output High Volt.	VOH	IOH=-0.5mA	0.9xVDD	—	—	V
Output Low Volt.	VOL	IOL=0.5mA	—	—	0.1xVDD	V
50% Check Board operating Current	IDD	VDD=3.3V	—	50	75	mA