



WINSTAR Display Co.,Ltd.
華凌光電股份有限公司



Winstar Display Co., LTD

華凌光電股份有限公司

WEB: <https://www.winstar.com.tw> E-mail: sales@winstar.com.tw



SPECIFICATION

MODULE NO.: WUABA**B120V0000N0NX00**

MODULE NO.: WUABL**B120V0000N0NX00**

1. Introduction :

1.1 Hardware

The WUABAB120V i.MX6 / WUABLB120V i.MX6 is a computer single board based on the NXP i.MX6 embedded System-on-chip (SoC). The SoC features a scalable multi-core ARM Cortex™ A9 processor with one to four corresponding versions. The module delivers high CPU and graphical performance with minimum power consumption.

The **WUAB series** incorporates DVFS (Dynamic Voltage and Frequency Scaling) and Thermal Throttling which enables the system to adjust operating frequency and voltage continuously. By changing in workload and temperature, it can be adjusted to be the best performance with the lowest power consumption.

The module targets a wide range of applications, including: **Digital Signage, Medical Devices, Navigation, Industrial Automation, HMI, Avionics, Entertainment system, POS, Data Acquisition, Thin Clients, Robotics, Gaming** and more.

It offers a wide range of interfaces from simple GPIOs, industry standard I2C, SPI, and UART buses through to high speed USB 2.0 interface and a 16/32bit external memory bus (parallel bus). The RGB and LVDS interface offer users to connect with high resolution displays.

1.2 Software

WUABAB120V iMX-6: The WUABAB120V iMX-6 with Android 4.4.2 and Embedded Linux images are also available.

WUABLB120V iMX-6 : The WUABLB120V iMX-6 with Linux Yocto Daisy 1.6 images is available.

Winstar supports additional Operating Systems. For further information and technical support, please contact with sales department.

1.3 Main Features

1.3.1 CPU

NXP SoC	i.MX6 Series
SoC Family	i.MX6 Dual Lite
CPU Cores	2
L1 Instruction Cache (each core)	32KByte
L1 Data Cache (each core)	32KByte
L2 Cache (shared by cores)	512KB
NEON MPE	✓
Maximum CPU frequency	1GHz
ARM Trust Zone	✓
Advanced High Assurance Boot	✓
Secure Real-Time Clock	✓

1.3.2 Memory

	i.MX6DL
DDR3 RAM Size	1GByte
DDR3 RAM Memory Width	64-bit
eMMC NAND Flash (8bit)	8GB
Expansion Memory	Micro SD Socket

1.3.3 Interface

	i.MX6DL 1GB
RGB	24-bits TTL with DE+ H/V sync
LVDS	Output 24 bit LVDS (1 channel)
HDMI	1 x HDMI (Type A)
Giga Ethernet	Ethernet 10M/100M/1GB
USB	2xUSB 2.0 Host(Dual Type A); 1 x USB 2.0 OTG (µUSB type AB) 2 x pin header (5-pin 2.54mm)
Serial port	RS232 (JST PHD compatible 2*5 pin/ 1 for console) ; RS232 (JST PH compatible *3, 1*5pin) RS485 (JST PH compatible *1,1*3pin)
GPIO	32-pin 3.3V TTL Level GPIOs
Resistive TP	4-wire
RTC	DS1307 (With Battery)
Audio	Wolfson WM8903 (Line out)
IIC	1 (Client, for PCAP use)

1.3.4 HD Video Decode

- MPEG-2 (Main, High Profile) – 1080p30, 720p60, (50Mbps)
- MPEG4/XviD (Simple, Advanced Simple Profile) – 1080p30 (40Mbps)
- H.263 (P0/P3) – 16CIF(1408x1152) 30fps (20Mbps)
- H.264 (Constrained Baseline, Baseline, Main, High Profile) – 1080p30, 720p60, (50Mbps)
- H.264-MVC (Baseline, Main, High Profile) – 720p60
- VC1 (Simple, Main, Advanced Profile) – 1080p30 (45Mbps)
- RV (8/9/10) – 1080p30 (40Mbps)
- DivX (3/4/5/6) – 1080p30(40Mbps)
- On2 VP6/VP8 – 720p30(20Mbps)
- AVS Jizhun – 1080p30 (40Mbps)
- MJPEG (Baseline) – 8192x8192 (120MPixel/s)

1.3.5 HD Video Encode

- MPEG4 (Simple Profile) – 720p30 (12Mbps)
- H.263 (P0/P3) – 4CIF(704x576) 30fps (8Mbps)
- H.264 (Constrained Baseline, Baseline Profile) – 1080p30, (14Mbps)
- MJPEG (Baseline) –8192x8192

1.3.6 Supported Operating Systems

- Android 4.4.2
- Linux Yocto Daisy 1.6

1.4 Interface Overview

The table shows the interfaces which support the i.MX6 Single board. The Serial interfaces can connect to different kinds of device, such as EEPROM and PCAP controller. We reserve an interface out for without driver version.

If you wish to use alternate function to special device, please contact with Winstar sales dept. for further technical support on driver programming.

Form Factor		
Processor System	CPU	iMX6DL - Dual core 1.0GHz (Dual core up to 1GHz per core)
Memory	Memory	Onboard DDR3L 1GB x64 bit
	Mass storage	On-board eMMC drive, up to 8GB
Video	LVDS	24 bit LVDS (1024*600、1280*800)
	RGB	24-bits TTL with DE+ H/V sync(800*480)
	HDMI	V1.4 (1920*1080)
Graphic	Graphic engine	Dedicated 2D Hardware accelerator Dedicated 3D Hardware accelerator(Supports OpenGL ES2.0 3D)
	H/W Video codec	Support MPEG 1/2/4, H.264 Hardware Decoder.
	Display	Support 2 types independent display with iMX6DL and i.MX6D/Q
Network	Ethernet	1 GbE + IEEE1588 with RJ45 slot
	WIFI/BT	BLE4.0(internalUSBforoptionWIFIModule, OptionalParts)
USB	USB	2 Standard USB 2.0 type A ; 1 x μ USB 2.0 OTG 2*USB2.0 with pin header
Audio	Audio	WM8903 Audio codec with 3.5 mm stereo jack Mic in, Line out internal pin header
I/O	Serial port	4 x RS232 (3 x ePH connector, 1x ePHD for console,) ; 1 x RS485 (1 x ePH connector)
	IIC	1 (Client, for PCAP use)
	GPIO	32-pin 3.3V TTL Level GPIOs/ 2-pin TTL PWM output
Touch Panel	Resistive	4-wire Resistive type(onboard)
	Capacitive	CTP is driven IIC interface
Clock	RTC	RTC Circuitry for low power consumption with Battery on-board
Expansion	SD Socket	1 * μ SD Slot (support up to SDXC)
Power	Voltage	DC9V~DC24V \pm 10%
	Consumption	2.5W
Environment	Temperature	-20 $^{\circ}$ C ~ 70 $^{\circ}$ C (Operating)
		-30 $^{\circ}$ C ~ 80 $^{\circ}$ C (Storage)
Operating System		Android 4.4.2 or Linux Yocto Daisy 1.6
Dimension		130mm * 95mm*20mm
Certification		CE/FCC

2. Architecture

2.1 Dimension

The single board of i.MX6 supports different kinds of connectors include Host USB, USB OTG, DC Jack, Audio Jack and RJ45. Customer may expand interfaces. Connectors can match 3 types of pin header/connector in **1.27mm**, **2.0mm** and **2.54mm**. The connectors are shown as below,

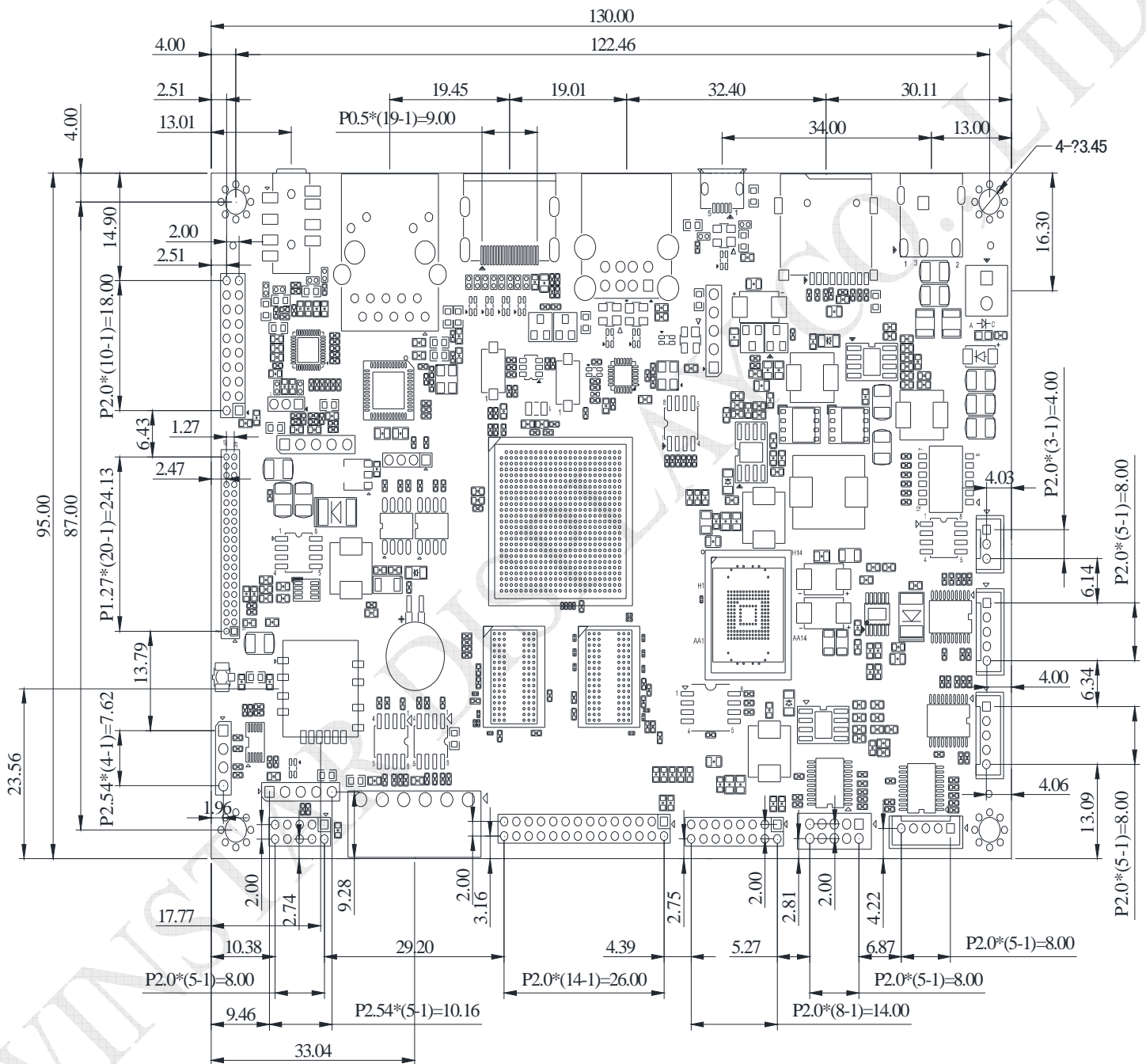

2.2 Block Diagram

The diagram shows the connection of IC components and devices.

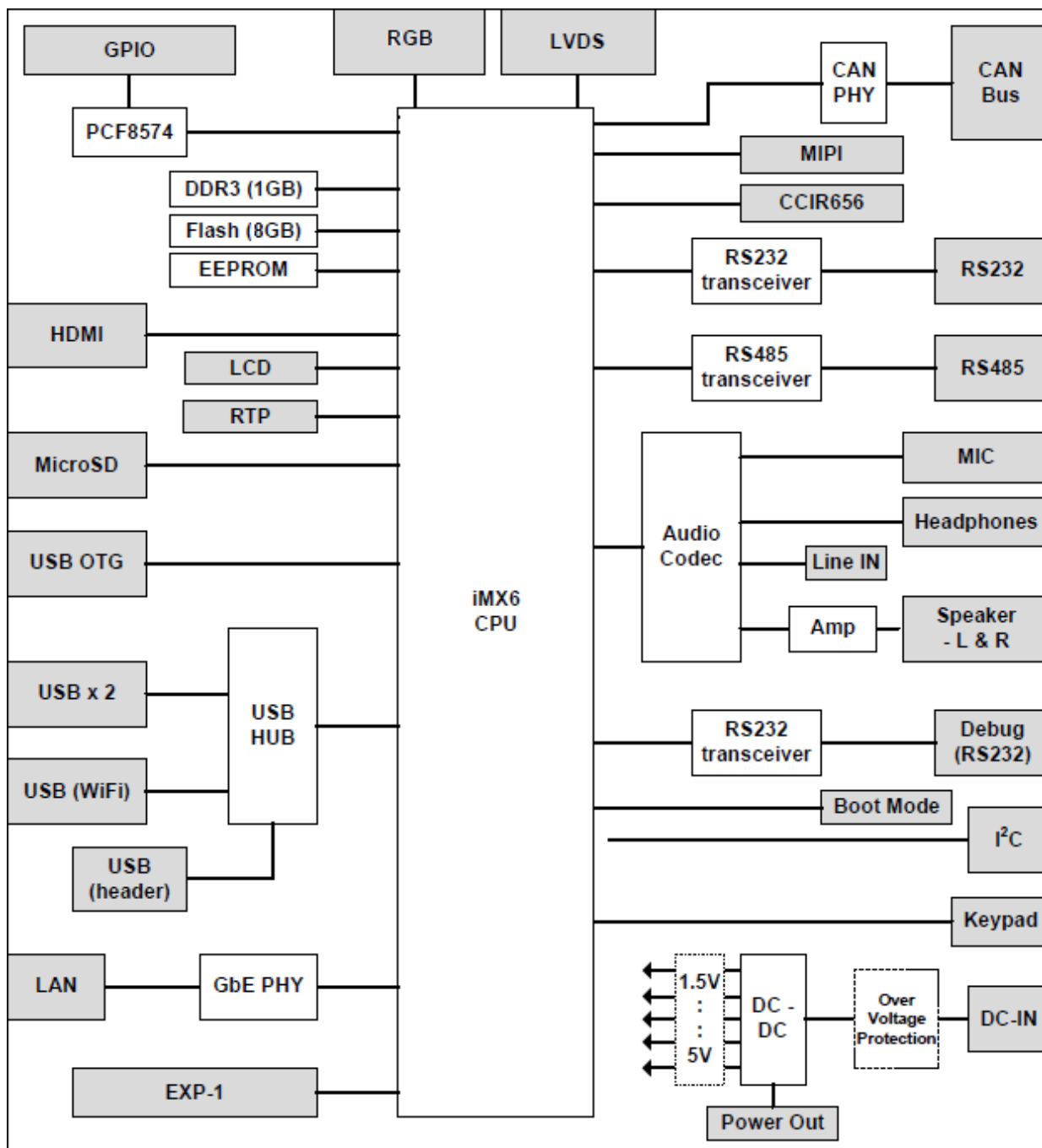

■ : Connectors or Pin-Headers

□ : Function blocks

2.3 Position of Connector and Pin header

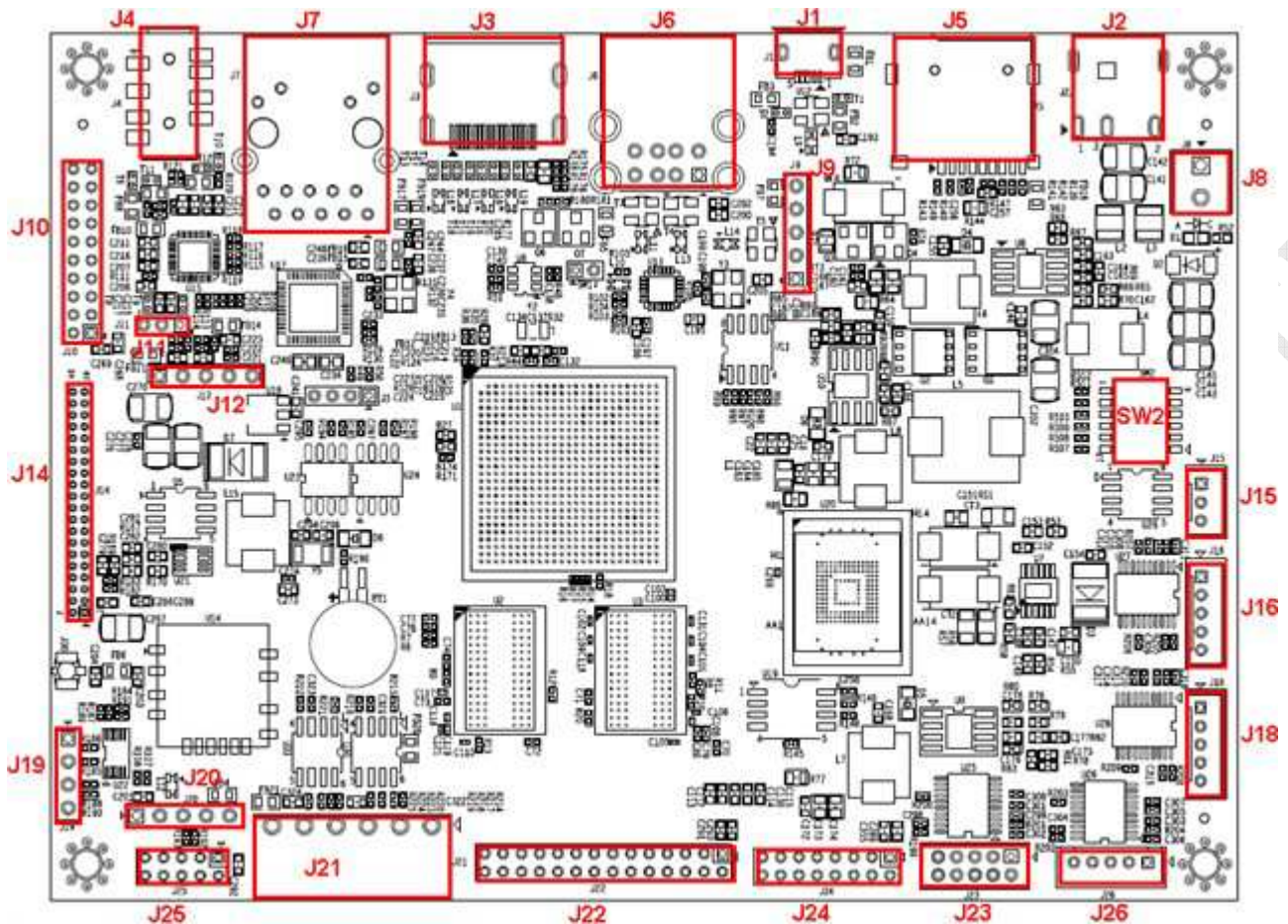

Connector No.	Description	Connector No.	Description
J2(J8)	DC Power Jack	J15	RS485 port
J5	Micro SD Card Slot	J11	Audio input interface
J6	USBport in Type A connector	J12	Audio output interface
J7	Ethernet in RJ45 Slot	J19	RTP interface
J22	GPIO port1	J4	3.5mm Earphone+ Micro phone
J24	GPIO port2	J1	USB OTG interface
J9, J20	USB port in pin header	J25	I2C interface for CTP(PCAP)
J16, J18, J26	RS232 port	J14	RGB LCD interfaces
J23	RS232 for Console	J3	HDMI (1920*1080)
J10	LVDS LCD interfaces		
SW2	Display selection switch		

3. Interface Description

3.1 Power Signal

The main power should provide DC9V~DC24V for Motherboard drive. DC12V can be transferred to DC5V and DC3.3V. DC5V and DC3.3V are for motherboard use only. DC12V is for Backlight setting. You have to provide DC12V for motherboard only while you use Winstar's TFT Module.

Pin	J2	J8
1	V+	V+
2	GND	GND

※ J2 By using 2.5mm DC Jack ; J8 By using 3.5mm Power terminal blocks

3.2 USB Port

The USB interfaces on WUABAB120V series include a USB2.0 OTG port and two USB2.0 host ports. Speed of up to 480 Mbps supported.

The USB2.0 host interface is connected to a hub controller to extend host ports. Two of the USB2.0 hub ports are available for users. The other two USB ports are reserved for 802.11b/g/n Wi-Fi module and 3G (WCDMA) module.

USB Port:

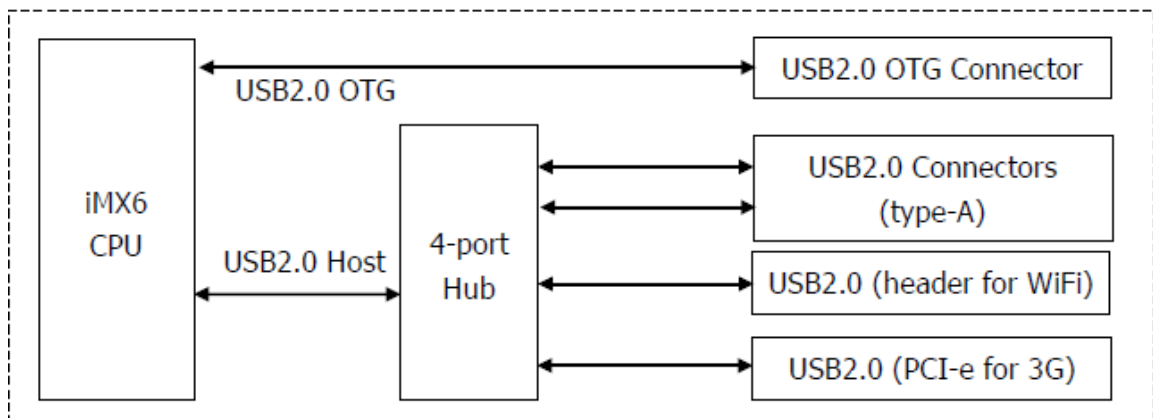



NOTE: The USB 2.0 OTG can be used in host mode or device mode. If you would like to use it in host mode, a separate OTG-to-host cable is required.

The USB2.0 host connector is a regular USB type A connector that can be connected to +5V USB storage device. This port is mainly used to connect to USB flash drive.

No.	Function	Connector type
J6	USB Host *2	USB Type A
J1	USB OTG	Micro USB type AB
J9/J20	USB 2.0	2.54mm Metal pin

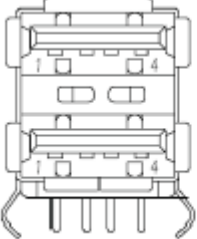
Pin	Signal	Pin	Signal
1	5V	1	5V
2	Data -	2	Data -
3	Data +	3	Data +
4	GND	4	ID
		5	GND

J6 : USB Type A Connector

J1 : USB OTG @ Micro USB Type AB

J9 and J20 : USB pin header Output

Pin no	I/O type	Function Name	Pin no	I/O type	Function Name
1	VCC	5.0V	2	TTL I/O	USB C-/D-
3	TTL I/O	USB C+/D+	4	VSS	GND
5	VSS	GND			

※ **J9 being not available while WIFI/BT module is mounted on the motherboard.**

3.3 Ethernet

The i.MX6 features a 10/100 M/1GB bit/s Ethernet interface. The MAC is integrated i.MX6 SoC and connected to an individual PHY located on the module. The KSZ9031RNX Fast Ethernet Transceiver chip is connected to the NXP i.MX6. The Fast Ethernet MAC in the SoC features an accurate IEEE 1588 compliant timer for clock synchronization which is mainly for industrial automation applications.

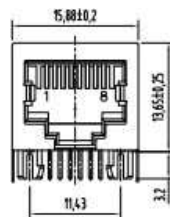

J7: Giga Ethernet

3.4 Display

The Single board i.MX6 features one Image Processing Unit (IPU). The unit provides function of camera, display connectivity, related processing synchronization and control. The output of the IPU can be routed individually to each of the display output interfaces such as two parallel LCD. The IPU has 2 display ports. Two external display output ports can be active at any given time.

Features of the Video Graphics Sub System include:

- Video Processing Unit (multi-standard video encoder/decoder)
- OpenGL ES 2.0
- 3D GPU
- 2D GPU
- Open VG acceleration
- Fully programmable display timing and resolution

3.4.1 Parallel RGB LCD interface

The Single board i.MX6 provides parallel LCD interfaces on the metal header. It supports up to 24-bit color per pixel. The 24bit color mapping is guaranteed to be compatible with Winstar modules. To ensure compatibility between modules, the display interface should always be used in 24-bit mode.

To use displays which require fewer bits (e.g. 18 or 16 bit displays), simply do not connect the bottom n LSBs for each color, where n is the number of signals that are not required for a specific color. For instance, to connect an 18-bit display, R0, R1, G0, G1 B0 and B1 will remain unused, and R2, G2 and B2 become the LSBs for this configuration. The 24-bit color mapping to the 18-bit mode is designed to be compatible with other modules.

Features:

- Up to WUXGA (1920x1200) resolution (Current resolution 800*480)
- Up to 24 bit color
- Supports parallel TTL displays and smart displays (reserved)
- Max pixel clock 165MHz

J14: TTL RGB LCD Interface : 1.27mm Dual Row 2*20 pin header

Pin Num	I/O Type	Function Name	Pin Num	I/O Type	Function Name
1	VCC	3.3V	2	TTL Output	PWM
3	VCC	3.3V	4	VDD	12V
5	TTL Output	NC	6	TTL Output	DISP0_CLK
7	TTL Output	NC	8	VSS	GND
9	VSS	GND	10	TTL Output	DISP0_HSYNC
11	TTL Input	Int	12	TTL Output	DISP0_VSYNC
13	TTL Output	DISP0_DEN	14	VSS	GND
15	VSS	GND	16	TTL Output	DISP0-DAT0
17	TTL Output	DISP0-DAT8	18	TTL Output	DISP0-DAT1
19	TTL Output	DISP0-DAT9	20	TTL Output	DISP0-DAT2
21	TTL Output	DISP0-DAT10	22	TTL Output	DISP0-DAT3
23	TTL Output	DISP0-DAT11	24	TTL Output	DISP0-DAT4
25	TTL Output	DISP0-DAT12	26	TTL Output	DISP0-DAT5
27	TTL Output	DISP0-DAT13	28	TTL Output	DISP0-DAT6
29	TTL Output	DISP0-DAT14	30	TTL Output	DISP0-DAT7
31	TTL Output	DISP0-DAT15	32	VSS	GND
33	TTL Output	DISP0-DAT20	34	TTL Output	DISP0-DAT16
35	TTL Output	DISP0-DAT21	36	TTL Output	DISP0-DAT17
37	TTL Output	DISP0-DAT22	38	TTL Output	DISP0-DAT18
39	TTL Output	DISP0-DAT23	40	TTL Output	DISP0-DAT19

The Backlight is driven by DC12V and the brightness control can be driven pin2.

3.4.2 LVDS interface

The LVDS interface (official name: FPD-Link/Flat Link) serialize the parallel RGB and control signals into differential LVDS pairs. Each LVDS signal pair contains up to 7 parallel signals. The single board i.MX6 SoC provides one integrated LVDS interface. A single channel LVDS interface can support resolutions up to 1366x768 pixels @60 frames per second (85MHz pixel clock maximum). The single channel mode is compatible with Winstar TFT modules from 7.0" to 12.1". The displays can have cloned content or can be driven independently from the IPU. LVDS with 2row *10 pin 2.0mm pin header is for TFT display.

J10: LVDS Cahnnel1 : 2.0mm Dual Row 2*10 pin header

Pin Num	I/O Type	Function Name	Pin Num	I/O Type	Function Name
1	VCC	3.3V	2	BL VCC	5V
3	VCC	3.3V	4	BL VCC	12V
5	LVDS-DATA	TX0-N	6	TTL Output	LVDS-EN
7	LVDS-DATA	TX0-P	8	TTL Output	PWM1
9	VSS	GND	10	LVDS-DATA	TX3-N
11	LVDS-DATA	TX1-N	12	LVDS-DATA	TX3-P
13	LVDS-DATA	TX1-P	14	VSS	GND
15	VSS	GND	16	LVDS-CLK	CLK-N
17	LVDS-DATA	TX2-N	18	LVDS-CLK	CLK-P
19	LVDS-DATA	TX2-P	20	VSS	GND

The backlight is driven by DC12V only and brightness can be adjusted at pin8 .

3.4.3 HDMI Interface

HDMI provides a unified method of transferring both video and audio data over a TMDS compatible physical link to an audio/visual display device. The HDMI interface is electrically compatible with the DVI standard.

Features

- HDMI 1.4a, HDCP 1.4, DVI 1.0 compliant
- Hot plug/unplug detection and link status monitor supported
- Video resolutions supported:
 - Up to 1080p@120Hz HDTV display
 - QXGA graphics display
 - HDMI 1.4a 4K x 2K video formats
 - HDMI 1.4a 3D video modes with up to 340MHz TMDS clock
- Supported color formats:
 - 24/30/36/48-bit RGB 4:4:4
 - 24/30/36/48-bit YCbCr 4:4:4
 - 16/20/24-bit YCbCr 4:2:2
- All audio formats as specified by the HDMI Specification Version 1.4a are supported

Pin	Signal	Pin	Signal
1	TMDS Data2+	11	TMDS Clock Shield
2	TMDS Data2 Shield	12	TMDS Clock-
3	TMDS Data2-	13	CEC
4	TMDS Data1+	14	NC
5	TMDS Data1 Shield	15	SCL
6	TMDS Data1-	16	SDA
7	TMDS Data0+	17	Ground
8	TMDS Data0 Shield	18	+5V
9	TMDS Data0-	19	Hot plug detect
10	TMDS Clock+		

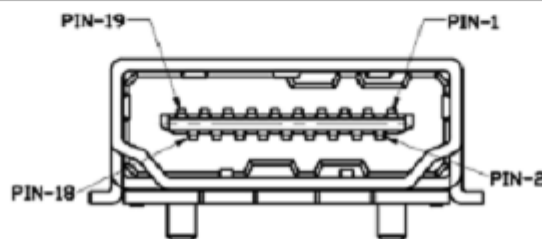

3.5 Analog Audio

The Single board i.MX6 offers analog audio input and output channels. On the motherboard, a WM8903 chip provides the analog audio interface. A stereo digital microphone interface is provided with a choice of two inputs.

J4 : 3.5mm Earphone+ Micro phone

OMTP "AV" Connector Interface	
Pin	Description
1	GND
2	Microphone
3	Right Side Earpiece
4	Left Side Earpiece



3.6 Serial Port (RS232/RS485)

The Single board i.MX6 offers five serial ports for general use. One port is using connector of PHD connector for console. The other ports include one RS485 serial port and three RS232 serial ports. All definitions of pins are shown as below:

J15: RS-485 port1 (JST 2.0mm/One row, 3 pin/180° PH connector)

Pin num	I/O type	Function Name
1	I/O Port	RS485-
2	I/O Port	RS485+
3	VSS	GND

J23: RS-232 for console (JST 2.0mm/Dual row 5 pin/ 180° PHD connector)

Pin num	I/O type	Function Name	Pin num	I/O type	Function Name
1	NC	NC	2	I/O Port	RS232-RX
3	I/O Port	RS232-TX	4	None	NC
5	VSS	GND	6	None	NC
7	I/O Port	RS232-RTS	8	I/O Port	RS232-CTS
9	None	NC	10	None	NC

J16,J18,J26: RS-232 port2/3/4 (JST 2.0mm/ one row 5 pin/180° PH connector)

Pin num	I/O type	Function Name
1	I/O Port	RS232-RX
2	I/O Port	RS232-TX
3	VSS	GND
4	I/O Port	RS232-RTS
5	I/O Port	RS232-CTS

Note : The Baud rate of RS232 is under 120K bps , For higher transmission rate should change the transceiver solution. The Baud rate of RS485 will reach 5M bps.

3.7 Micro SD Connector

The micro SD host connector has the following specification:

- SD Host Controller Standard Specification version 3.0
- MMC System Specification version 4.2/4.3/4.4
- SD Memory Card Specification version 3.0 and supports the Extended Capacity SD Memory Card
- SDIO Card Specification version 3.0

J5 Micro SD Connector Pin-out

Pin	Signal	Pin	Signal
1	Data 2	6	GND
2	Data 3	7	Data 0
3	CMD	8	Data 1
4	VDD	9	CD
5	CLK		

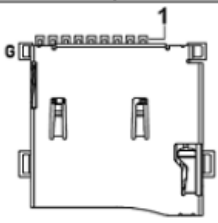

3.8 GPIOs

Most of the pins have GPIO (General Purpose Input/Output) function. The GPIO functions are configured by driving external peripheral device or detected signal through external contact. The Single board i.MX6 provides 32 TTL I/O ports and two PWM output function pin. The pin definition are shown as below:

J22 : 2.0mm Dual Row (2*14pin header)

Pin num	I/O type	Function Name	Pin num	I/O type	Function Name
1	VCC	3.3V	2	VCC	3.3V
3	TTL I/O	GPIO4-1	4	TTL I/O	GPIO4-2
5	TTL I/O	GPIO4-3	6	TTL I/O	GPIO4-4
7	TTL I/O	GPIO4-5	8	TTL I/O	GPIO4-6
9	TTL I/O	GPIO4-7	10	TTL I/O	GPIO4-8
11	TTL I/O	GPIO4-9	12	TTL I/O	GPIO4-10
13	TTL I/O	GPIO4-11	14	TTL I/O	GPIO4-12
15	TTL I/O	GPIO4-13	16	TTL I/O	GPIO4-14
17	TTL I/O	GPIO4-15	18	TTL I/O	GPIO4-16
19	TTL I/O	GPIO4-17	20	TTL I/O	GPIO4-18
21	TTL I/O	GPIO4-19	22	TTL I/O	GPIO4-20
23	TTL I/O	GPIO4-21	24	TTL I/O	GPIO4-22
25	TTL I/O	GPIO4-23	26	TTL I/O	GPIO4-24
27	VSS	GND	28	VSS	GND

J24 : 2.0mm Dual Row 2*8 pin header

Pin num	I/O type	Function Name	Pin num	I/O type	Function Name
1	VCC	3.3V	2	VCC	3.3V
3	TTL I/O	GPIO5-1	4	TTL I/O	GPIO5-2
5	TTL I/O	GPIO5-3	6	TTL I/O	GPIO5-4
7	TTL I/O	GPIO5-4	8	TTL I/O	GPIO5-6
9	TTL I/O	GPIO5-7	10	TTL I/O	GPIO5-8
11	TTL I/O	PWM0	12	TTL I/O	PWM1
13	VCC	3.3V	14	VCC	3.3V
15	VSS	GND	16	VSS	GND

3.9 Resistive Touch panel Interface

The Single board i.MX6 use AK4183 chip as resistive touch panel controller to connect with SoC. AK4183 supports 4-Wire, 5-Wire and 8-Wire Analog Resistive touch panel operation.

4-wire resistive touch panel of TFT modules are suitable for this Single board.

The definition of pin is shown as below:

J19 : Resistive Touch Panel interface

Pin no.	I/O type	Function Name	Pin no.	I/O type	Function Name
1	Analog I/O	X+	2	Analog I/O	X-
3	Analog I/O	Y+	4	Analog I/O	Y-

3.10 Audio Line-out

The Single board iMX6 offers another analog audio output channel with metal pin besides J10 for general use. On the motherboard, a WM8903 chip provides the analog audio interface. The pin definitions are shown as below:

J12 : Line-out pinheader

Pin num	I/O type	Function Name	Pin num	I/O type	Function Name
1	VSS	GND	2	Analog Out	Aud-lineL
3	VCC	5.0V	4	Analog Out	Aud-lineR
5	VSS	GND			

Audio Interfaces:

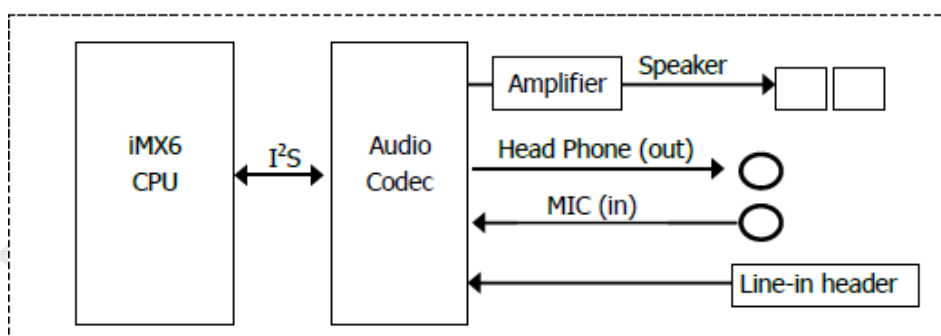

For the analog audio input channel with metal pin besides J15 for general use; chip WM8903 provides the analog audio input interface, the pin definitions are shown as below :

J11 : Line-in pin header (2.0mm pin header)

Pin num	I/O type	Function Name	Pin num	I/O type	Function Name
1	Analog Input	Line-L	2	VSS	GND
3	Analog Input	Line-R			

3.11 PWM (Pulse Width Modulation)

The Single board iMX6 features a four channel Pulse Width Modulator (PWM). Each PWM channel features a 16-bit up-counter with clock source selection. There is a 16 bit 4 level deep FIFO available in order to minimize the interrupt overhead. There is a 12-bit prescaler available for dividing the clock.

The PWM interface can be used as an easy way to simulate a DAC and generate a variable DC voltage when a suitable RC circuit is selected. Other functions include control of LED brightness, display backlights or servo motors. These PWM Channels are released based on different connectors. The connector information is shown as below:

PWM NO.	Connector
PWM0,1	J24
PWM2	J14
PWM3	J10

4. Selection of Display

The Single board i.MX6 features 5 types TFT Module can be embedded. It includes two interface (RGB/LVDS), three resolution, four sizes and five Modules. By adjusting "SW2" to get the module is needed. The methods of adjustment are shown as below:

SW2						Resolution	Display Interface	Touch Panel	Remark
6	5	4	3	2	1				
0	0	0	0	0	0	1024x768	LVDS	RTP	RTP always present
1	0	0	0	0	0	1024x768	LVDS	PCAP	J25
X	0	1	0	0	1	800x480	RGB	RTP	RTP always present
1	0	1	0	0	1	800x480	RGB	PCAP	J25
X	0	0	0	1	0	1024x600	LVDS	RTP	RTP always present
1	0	0	0	1	0	1024x600	LVDS	PCAP	J25
X	0	0	0	1	1	1280x800	LVDS	RTP	RTP always present
1	0	0	0	1	1	1280x800	LVDS	PCAP	J25

Note:

- 5.0" and 7.0" TFT Module in RGB interface (Resolution 800*480).
- 7.0" and 10.1" TFT Module in LVDS interface (Resolution 1024*600).
- 10.1" and 12.1 TFT Module in LVDS interface (Resolution 1280*800).

5. Technical Specification

5.1 Absolute Maximum Ratings

Symbol	Description	Min	Max	Unit
Vmax_12V	Main power supply	-0.5	13	V
Vmax_5V	Digital power supply 1	-0.3	5.25	V
Vmax_3V3	Digital power supply 2	-0.3	3.6	V
Vmax_VBAT	RTC power supply	-0.3	3.3	V
Vmax_IO	IO pins with GPIO function	-0.5	3.6	V

※ DC12V for Backlight drive.

5.2 Electrical Characteristics

◎ Recommended operation condition

Symbol	Description	Min	Typical	Max	Unit
12V	Main power supply*Note	11.5	12.0	12.5	V
5V	Digital power supply 1	4.75	5.0	5.25	V
3.3V	Digital power supply 2	3.0	3.3	3.5	V
VBAT	RTC powersupply	2.8	3.0	3.2	V

*Note : Main power supply for DC12V is for driving with Winstar TFT Module.

◎ Typical power consumption

Symbol	Description (VCC = 3.3V)	Typical	Unit
IDD_IDL	CPU Idle	TBD	mA
IDD_HIGH CPU	Maximal CPU Load	TBD	mA
IDD_RGB	Resolution on RGB	TBD	mA
IDD_LVDS	Resolution on LVDS	TBD	mA
IDD_SUSPEND	Module in Suspend State	TBD	mA
IDD_BATT	Current consumption of internal RTC	40	μA

6. Optional Parts

The Single board iMX6 has two standard optional devices, **WIFI/BT Module**. And they will be introduced as below:

6.1 WIFI/BT Module

RTL8723BU is a highly integrated single-chip 802.11n Wireless LAN (WLAN) USB 2.0 Multi-Function network interface controller with integrated Bluetooth 2.1/3.0/4.0 controller. It combines a WLAN MAC, a 1T1R capable WLAN baseband, and RF in single chip. The RTL8723BU provides a complete solution for a high-performance integrated wireless and Bluetooth device. The integration provides better coordination between 802.11 and Bluetooth, and with sophisticated dynamic power control and packet traffic arbitration, RTL8723BU is able to provide the best coexistence performance Overview.

6.1.1 WLAN and BTfeatures

General features	<ul style="list-style-type: none"> ■ CMOS MAC, Baseband PHY, and RF in a single chip for IEEE 802.11b/g/n compatible WLAN ■ Complete 802.11n solution for 2.4G band
Host Interface	<ul style="list-style-type: none"> ■ Complies with USB Specification Revision 2.0
Standards Supported	<ul style="list-style-type: none"> ■ IEEE 802.11b/g/n compatible WLAN ■ IEEE 802.11e QoS Enhancement (WMM) ■ IEEE 802.11h TPC, Spectrum Measurement ■ 802.11i (WPA, WPA2). Open, shared key, and pair-wise key authentication services ■ BT v2.1, EDR/BT v3.0 and HS/BT v4.0
WLAN MAC Features	<ul style="list-style-type: none"> ■ Frame aggregation for increased MAC efficiency (A-MSDU, A-MPDU) ■ Low latency immediate High-Throughput Block Acknowledgement (HT-BA) ■ Long NAV for media reservation with CF-End for NAV release ■ PHY-level spoofing to enhance legacy compatibility ■ Power saving mechanism ■ Channel management and co-existence ■ Transmit Opportunity (TXOP) Short Inter-Frame Space (SIFS) bursting for higher multimedia bandwidth
WLAN PHY Features	<ul style="list-style-type: none"> ■ IEEE 802.11n OFDM ■ One Transmit and one Receive path (1T1R) ■ 20MHz and 40MHz bandwidth transmission ■ Short Guard Interval (400ns) ■ DSSS with DBPSK and DQPSK, CCK modulation with long and short preamble ■ OFDM with BPSK, QPSK, 16QAM, and 64QAM modulation. Convolutional Coding Rate: 1/2, 2/3, 3/4, and 5/6 ■ Maximum data rate 54Mbps in 802.11g and 150Mbps in 802.11n ■ Switch diversity for DSSS/CCK

	<ul style="list-style-type: none"> ■ Hardware antenna diversity ■ Selectable receiver FIR filters ■ Programmable scaling in transmitter and receiver to trade quantization noise against increased probability of clipping Fast ■ Receiver Automatic Gain Control (AGC) ■ On-chip ADC and DAC
BT Controller	<ul style="list-style-type: none"> ■ 1Mbps for Basic Rate; 2,3Mbps for Enhanced Data Rate; 6,9,12,18,24,36,48,54Mbpsfor High Speed ■ AFH, Time Division for Media Access Control ■ 8DPSK, $\pi/4$ DQPSK, GFSK for Modulation Techniques ■ PCM interface for audio data transmission via BT controller. ■ Integrated MCU to execute Bluetooth protocol stack ■ Support all packet types in basic rate and enhanced data rate ■ Support SCO / eSCO link (allow one link for PCM interface and three links for HS-UART) ■ Support 4 piconets in a scattern ■ Support Secure Simple Pairing ■ Support Low Power Mode (Sniff / Sniff Sub-rating / Hold / Park) ■ Enhanced BT/WIFI Coexistence Control to improve transmission quality in different profiles ■ Bluetooth 4.0 Dual Mode support: Simultaneous LE and BR/EDR ■ Support multiple states of Low Energy to increase the flexibility of application
Bluetooth Transceiver Features	<ul style="list-style-type: none"> ■ Fast AGC control to improve receiving dynamic range ■ Support AFH to dynamically detect channel quality to improve transmission quality ■ Integrated internal class 1, class 2, and class3 PA ■ Bluetooth 3.0+HS compliant ■ Power Control / Enhanced Power Control Supported ■ Bluetooth Low Energy supported ■ Integrated 32K oscillator for power management

6.1.2 Block Diagram

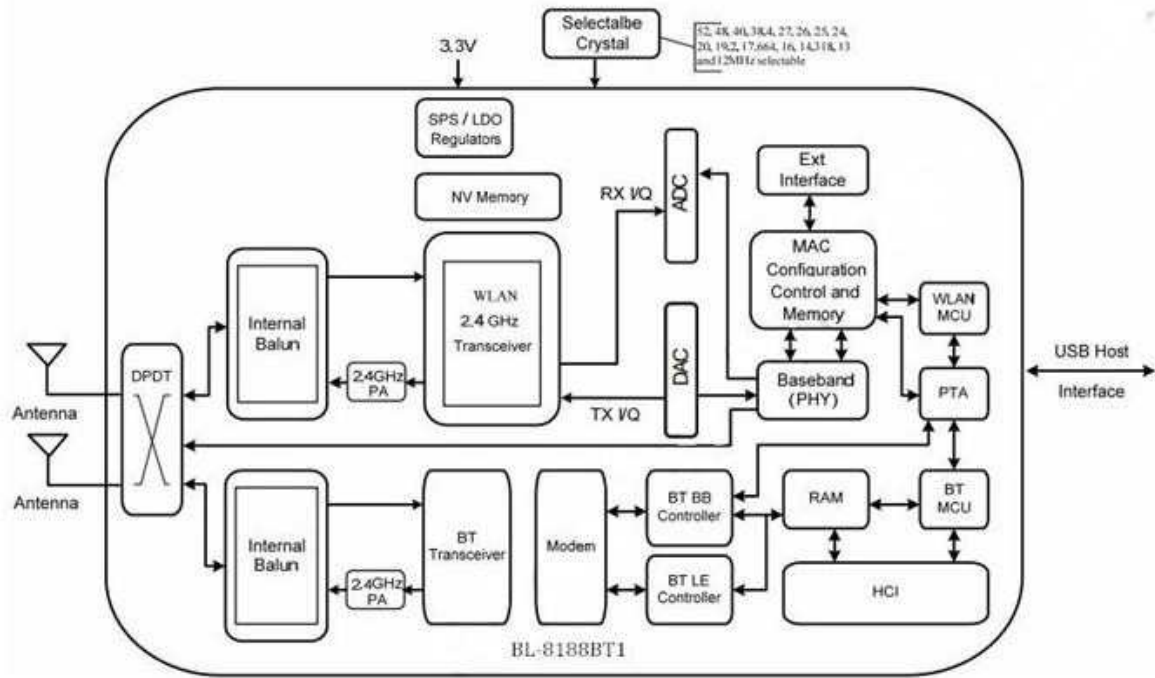

6.1.3 Functional Specification

Standards	WiFi: IEEE802.11b, IEEE802.11g, Draft IEEE802.11n, IEEE802.11d, IEEE802.11e, IEEE802.11h, IEEE802.11i BT: V2.1+EDR, BT v3.0, BT v3.0+HS
Bus Interface	USB 2.0
Form Factor	19.5mm x 12.5mm x 1.5mm (L x W x H)
Data Rate	802.11b: 11, 5.5, 2, 1 Mbps 802.11g: 54, 48, 36, 24, 18, 9, 6 Mbps 802.11n: MCS 0 to 7 for HT20Mbps MCS 0 to 7 for HT40Mbps BT: 1Mbps for Basic Rate 2.3Mbps for Enhanced Data Rate 6, 9, 12, 18, 24, 36, 48, 54 Mbps for High Speed
Media Access Control	WiFi: CSMA/CA with ACK BT: AFH, Time Division

Modulation Techniques	802.11b: CCK, DQPSK, DBPSK 802.11g: 64QAM, 16 QAM, QPSK, BPSK 802.11n: 64QAM, 16 QAM, QPSK, BPSK BT: 8DPSK, $\pi/4$ DQPSK, GFSK		
Network Architecture	WiFi: Infrastructure mode Software AP WiFi Direct BT: Pico Net Scatter Net		
Operating Channel	WiFi 2.4GHz: 11: (Ch. 1-11) – United States 13: (Ch. 1-13) – Europe 14: (Ch. 1-14) – Japan BT 2.4GHz: Ch.0-78		
Frequency Range	2.400GHz ~ 2.4835 GHz		
Transmit Output Power – 1x1 (Tolerance: +-1.5dBm)	802.11b@11Mbps 16dBm	802.11g@6Mbps 16dBm 802.11g@54Mbps 14dBm	802.11n 16dBm(MCS0_HT20) 13dBm(MCS7_HT20) 13dBm(MCS0_HT40) 13dBm(MCS7_HT40)
	BT: -89dBm@1Mbps, -90dBm@2Mbps, -83dBm@3Mbps		
Receiver Sensitivity	802.11b@11Mbps -82dBm	802.11g@54Mbps -71dBm	802.11n -67dBm(MCS7_HT20) -64dBm(MCS7_HT40)
	BT: -80dBm@1Mbps, -90dBm@2Mbps, -83dBm@3Mbps		
Security	WiFi: WPA, WPA-PSK, WPA2, WPA2-PSK, WEP 64bit & 128bit, IEEE 802.11x, IEEE 802.11i BT: Simple Paring		
Power Consumption (3.3V) (Typical)	WiFi: TX Mode: (Continuous mode)		

	190mA (MCS7/BW40/13dBm) RXMode: (Continuous mode) 150mA (MCS7/BW40/-60dBm) Associated Idle: 120mA Unassociated Idle: 130mA RF disable Mode: 120mA BT: Inquiry & Page Scan: 1.7mA ACL no traffic: 15mA SCO HV3: 30mA Parked 1.28s beacon: 1.12mA Reset: 0.05mA
--	---

6.1.4 Dimension :

